

A minerals research contract report
November 1981

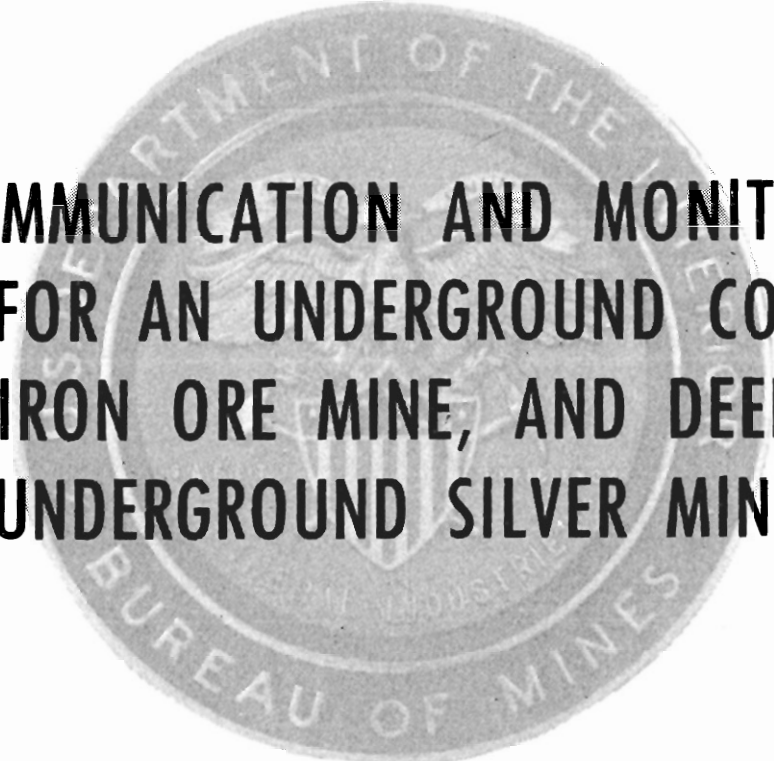

**A COMMUNICATION AND MONITORING
SYSTEM FOR AN UNDERGROUND COAL MINE,
IRON ORE MINE, AND DEEP
UNDERGROUND SILVER MINE**

Contract S0133035 and J0377076
Rockwell International
Collins Government Avionics Division
Cedar Rapids, Iowa 52498

The views and conclusions contained in this document are those of the authors and should not be interpreted as necessarily representing the official policies or recommendations of the Interior Department's Bureau of Mines or of the U.S. Government.

REPORT DOCUMENTATION PAGE	1. REPORT NO.	2.	3. Recipient's Accession No. 523-0768901-00121D
4. Title and Subtitle Communication and Monitoring System for an Underground Coal Mine, Iron Ore Mine, and Deep Underground Silver Mine		5. Report Date November 1981	
7. Author(s) Alan A. Bergeron, R. L. Collins, J. L. Michels		6.	
9. Performing Organization Name and Address Rockwell International Collins Government Avionics Division Cedar Rapids, Iowa 52498		8. Performing Organization Rept. No.	
12. Sponsoring Organization Name and Address United States Bureau of Mines Department of the Interior Washington, D.C.		10. Project/Task/Work Unit No. 11. Contract(C) or Grant(G) No. (C) SO133035 (G) JO377076	
15. Supplementary Notes Technical work was performed under contract SO133035. Final report was prepared under JO377076.		13. Type of Report & Period Covered Final	
16. Abstract (Limit: 200 words) Advanced communication and monitoring systems were developed and demonstrated in three underground mines representing different mining techniques, geographical areas, and material mined. The first mine was a large coal mine in western Pennsylvania that used room and pillar techniques and continuous mining methods. The system developed for this mine provided private telephone channels, environmental monitoring, and control of underground equipment, all on a single coaxial cable, with all system operations under the direction of a minicomputer. Many advanced features were incorporated into the system, such as paging of roving personnel, two-way section wireless, through-the-earth emergency communication, and redundant signal paths. Television was multiplexed into the system for underground equipment surveillance. A hoist radio system completed the complement of equipment at the mine. The second mine was a magnetite ore mine in eastern Pennsylvania that used block caving mining techniques. A radio system was developed that provided two-way communications between trackless vehicles and roving personnel. A unique system of uhf/vhf repeaters combined with a "leaky-feeder" transmission line offered operational and emergency features not previously found in mine communication systems. Evacuation alarming, personnel paging, fan-hole drill operator communications, and maintenance and safety vehicle dispatch were provided. The system required no dispatcher and operated during power failure. A hoist communications/shaft inspection system completed the installation. The third mine was a deep silver mine in the Cour d' Alene district of Idaho. The system developed for this mine utilizes a single wire pair to provide up to 14 voice channels. A unique combination of PBX, telephone carrier system, and intercoms offered private conversations, selective signaling and emergency backup communications. Two hoist communication systems were installed to provide a voice link and in-cage bellling signal between hoistman and cage.			
17. Document Analysis a. Descriptors Frequency division multiplex Mine communications Computer-based communications monitoring b. Identifiers/Open-Ended Terms "Leaky-feeder" communications Uhf Hoist communications Hoist phones PBX Coaxial cable c. COSATI Field/Group			
18. Availability Statement Release Unlimited		19. Security Class (This Report) Unclassified	21. No. of Pages 309
		20. Security Class (This Page) Unclassified	22. Price

FOREWORD

This report was prepared by Rockwell International, Collins Government Avionics Division, Cedar Rapids, Iowa 52498, under USBM contract number J0377076. The contract was initiated under the Coal Mine Health and Safety Program. It was administered under the technical direction of the Pittsburgh Research Center with Mr. Harry Dobroski, Jr. acting as Technical Project Officer. Mr. Larry Guess was the contract administrator for the Bureau of Mines. This report is the summary of the work recently completed as part of this contract during the period June 1973 to March 1978. This report was submitted by the authors during November 1981.

The technical work associated with this report was performed under S0133035, and concerned three mines. Mr. Harry Dobroski, Jr. was Technical Project Officer for Section I (Robena Mine) and Mr. Robert L. Chufo was Technical Project Officer for Sections II and III (Grace and Sunshine Mines).

ABSTRACT

Advanced communication and monitoring systems were developed and demonstrated in three underground mines representing different mining techniques, geographical areas, and material mined.

The first mine was a large coal mine in western Pennsylvania that used room and pillar techniques and continuous mining methods. The system developed for this mine provided private telephone channels, environmental monitoring, and control of underground equipment, all on a single coaxial cable, with all system operations under the direction of a minicomputer. Many advanced features were incorporated into the system, such as paging of roving personnel, two-way section wireless, through-the-earth emergency communication, and redundant signal paths. Television was multiplexed into the system for underground equipment surveillance. A hoist radio system completed the complement of equipment at the mine.

The second mine was a magnetite ore mine in eastern Pennsylvania that used block caving mining techniques. A radio system was developed that provided two-way communications between trackless vehicles and roving personnel. A unique system of uhf/vhf repeaters combined with a "leaky-feeder" transmission line offered operational and emergency features not previously found in mine communication systems. Evacuation alarming, personnel paging, fan-hole drill operator communications, and maintenance and safety vehicle dispatch were provided. The system required no dispatcher and operated during power failure. A hoist communications/shaft inspection system completed the installation.

The third mine was a deep silver mine in the Cour d'Alene district of Idaho. The system developed for this mine utilizes a single wire pair to provide up to 14 voice channels. A unique combination of PBX, telephone carrier system, and intercoms offered private conversations, selective signaling, and emergency backup communications. Two hoist communication systems were installed to provide a voice link and in-cage belling signal between hoistman and cage.

INTRODUCTION

Background

With the passage of the Federal Coal Mine Health and Safety Act of 1969, Congress acted to improve the disease and injury record associated with the mining of coal. Also, the Federal Mine Safety and Health Amendments Act of 1977 reemphasized the necessity of improving the safety record associated with mining metal and nonmetal commodities in the United States. The Bureau of Mines has been addressing this problem under its organic act of 1910 and in support of the regulatory functions under Public Law 81-577 and the Federal Metal and Nonmetallic Mine Safety Act of 1966. The new legislation has highlighted this problem and the Bureau of Mines has continued to respond with continued research in many areas, one being the development of new or improved means and methods of communications during normal day-to-day and emergency situations.

Description

This three-part report describes the efforts taken to fulfill the above requirement under the Engineering and Administrative Services Contract USBM S0133035 and J0377076. Contract effort began in June 1973 and included three mines. The three mines selected to demonstrate the improved communications concepts were the Robena Coal Mine complex located in southwestern Pennsylvania (Section I); the Grace Iron Ore Mine located at Morgantown, Pennsylvania (Section II); and the Sunshine Deep Metal Mine located in Big Creek Canyon, Shoshone County, Idaho (Section III).

All phases of the project from the initial site survey through the follow-on support are discussed. The communications and monitoring problems at the three mines along with the steps taken to correct these problems are described. A list of installed equipment and their specifications are also included. Installation and maintenance problems are reviewed and recommendations given. Test data taken during preinstallation and evaluation are also included.

The effort for each mine began with several surveys to identify specific needs. Keeping constraints of the contract in mind, a report was prepared and submitted to the United States Bureau of Mines Technical Project Officer (TPO), identifying the individual mine's needs and making recommendations for possible solutions to satisfy these needs. Using the recommendations as a guide, a source for equipment procurement was located and identified to the USBM. After purchase, the equipment was forwarded to Collins Commercial Telecommunications Division, Rockwell International. After receipt of the equipment at its Cedar Rapids facilities, Rockwell-Collins formulated the equipment into subsystems and subjected it to testing and analysis. The equipment was repackaged so as to withstand the harsh environment encountered in the mines.

When testing, analysis, and repackaging were completed, the equipment was forwarded to the mine for installation. Each mine was provided installation training, drawings, and assistance when necessary.

After installation, the system's capabilities were demonstrated to the Bureau of Mines and mine personnel at an acceptance meeting. Following the demonstration, all parties reviewed the system and recommended changes. All approved changes were incorporated as in-field modifications.

Field support and system modifications were provided for the duration of the contract.

SECTION I

ROBENA MINE

	Page
1.0 INTRODUCTION.....	23
2.0 ROBENA MINE DESCRIPTION	25
3.0 STATEMENT OF THE PROBLEM	27
3.1 Communication System	27
3.2 Monitoring Systems	28
3.3 Hoist Communication	29
4.0 PLANNED SOLUTION	31
4.1 Contract Brief	31
4.2 Survey Results.....	32
4.3 Proposed Solutions	33
4.3.1 Communication and Monitoring	33
4.3.2 Shaft Hoist Communications	36
5.0 HARDWARE IMPLEMENTATION DESCRIPTION	39
5.1 Communications and Monitoring	39
5.1.1 System Operation	40
5.1.2 Hardware Description	45
5.1.3 Installation	61
5.1.4 Follow-On Modification, Maintenance, and Support ..	81
5.2 Hoist Communications	84
5.2.1 Hardware Description	84
5.2.2 Installation	87
5.2.3 Follow-On Maintenance and Support	87
6.0 RECOMMENDATIONS/CONCLUSIONS	93
7.0 EQUIPMENT SPECIFICATIONS	97
7.1 Communications and Monitoring System	97
7.2 Hoist Communication System	99
8.0 COMMUNICATIONS AND MONITORING SYSTEM PERFORMANCE TESTS	101
8.1 Tests Performed	101
8.2 Hoist Communication System Performance Tests	104

List of Illustrations

Figure	Page
2-1 Robena Mine Complex	25
4-1 Concept of Operation for Proposed Communications and Monitoring System	37
4-2 Hoist Communications System	38
5-1 Functional Block Diagram of Whole Mine Communication and Monitoring System.....	40
5-2 FDM Frequency Spectrum and Allocations	41
5-3 Paging/Emergency System.....	43
5-4 TV Monitor System.....	45
5-5 System Center With Processor, DITM, and Teleprinter.....	46
5-6 Monitor/Control Display Matrix (Preliminary)	47
5-7 System Center With Monitor/Control Matrix (Final).....	48
5-8 Surface Telephone	50
5-9 Initial Design or Demo Version Underground Phone.....	51
5-10 Underground Telephone With Redesigned Enclosure	51
5-11 Three-Function Environmental Monitor.....	52
5-12 Fire Monitor	52
5-13 Monitor/Control Unit	53
5-14 Pocket Pager (Call Alert Receiver)	54
5-15 Escapeway Receiver	55
5-16 Radio Interface	56
5-17 Four-Port Surface Tap.....	57
5-18 Underground Cable Tap	58
5-19 Power Inserter	58
5-20 Underground Line Amplifier.....	59
5-21 Line Amplifier Battery Pack	59
5-22 Telephone Test Set	60
5-23 Communications and Monitoring System Lab Test Setup.....	63
5-24 Cable Splice With Installation Equipment	64
5-25 Robena Demonstration System	65
5-26 Robena Communications and Monitoring System Installation Less Loopback, Coupler Interface, and the TV Monitor System.....	69
5-27 Surface Telephone Installation	70
5-28 Underground Telephone Mounted on Wooden Post	72
5-29 Underground Telephone Mounted on Jackpost.....	73

List of Illustrations (Cont)

Figure	Page
5-30 Three-Function Environmental Monitor Installation.....	74
5-31 Fire Monitor Installation	75
5-32 Underground Line Amplifier With Strain Relief.....	76
5-33 Miner With Pocket Pager.....	77
5-34 Loop-Back Cable Installation	79
5-35 Block Diagram Showing Transceivers, Couplers, Hoist Rope and Interconnections.....	85
5-36 Hoist Communication System-Hardware	85
5-37 Cage Transceiver and Battery in Protective Enclosure	86
5-38 Hoist Room Transceiver With Boom Microphone	88
5-39 Cage Coupler Installation.....	89
5-40 Cage Transceiver Installation.....	90

List of Tables

Table	Page
5-1 Equipment List	61
5-2 Initial Communication and Monitoring Equipment Locations.....	66

SECTION II

GRACE MINE

	Page
1.0 INTRODUCTION.....	107
2.0 GRACE MINE DESCRIPTION	109
3.0 STATEMENT OF THE PROBLEM	113
3.1 Telephone Network	113
3.2 Vehicular Communications.....	113
3.3 Fan-Hole Drill Operator.....	113
3.4 Hoist Communications.....	114
3.5 Emergency Warning System	114
3.6 Fan Monitoring	114
3.7 Mine Drainage Monitoring	115
3.8 Underground Environmental Monitoring	115
3.9 Summary	115
4.0 PLANNED SOLUTION	117
4.1 Contract Brief	117
4.1.1 Phase 1 -- Communications Survey	117
4.1.2 Phase 2 -- Whole Mine Communications/ Monitoring Systems	117
4.1.3 Phase 3 -- Preparation of Equipment Procurement	117
4.1.4 Phase 4 -- Equipment Acceptance	117
4.1.5 Phase 5 -- Systems Installation	118
4.1.6 Phase 6 -- Maintenance Training Program	118
4.1.7 Phase 7 -- Systems Operability.....	118
4.1.8 Phase 8 -- Field Support and Modification	118
4.2 Survey Results	118
4.3 Proposed Solutions	119
4.3.1 Shaft Hoist Communications	119
4.3.2 Dispatching and Communication for the Underground Ambulance	119
4.3.3 Communication With Fan-Hole Drill Operators	119
4.3.4 Paging or Call Alert of Supervisory Personnel	119
4.3.5 Refuge Chamber Communications System	121
4.3.6 Wireless Haulage Communications System	121
4.3.7 New Monitoring Systems To Be Installed	124

Table of Contents (Cont)

	Page
5.0	HARDWARE IMPLEMENTATION DESCRIPTION 127
5.1	Hoist Communications 127
5.1.1	Hardware Description 127
5.1.2	Installation 130
5.1.3	Follow-On Maintenance and Support 134
5.2	RF "Leaky-Feeder" Communications System 134
5.2.1	System Operation 135
5.2.2	Hardware Description 137
5.2.3	Installation 139
5.2.4	Follow-On Maintenance and Support 147
6.0	RECOMMENDATIONS/CONCLUSIONS 151
7.0	EQUIPMENT SPECIFICATIONS 155
7.1	Hoist Radio Communications System..... 155
7.2	"Leaky-Feeder" Communications System..... 157
8.0	PERFORMANCE TESTS 161
8.1	Hoist Radio Performance Tests 161
8.2	System Performance Data -- "Leaky-Feeder" Communications System 164
9.0	RF "LEAKY-FEEDER" COMMUNICATIONS SYSTEM DESIGN..... 195
9.1	Cabling Selection..... 195
9.2	System Design 206
10.0	RF "LEAKY-FEEDER" COMMUNICATION EQUIPMENT MODIFICATIONS 213
10.1	Introduction 213
10.2	System Operation 213
10.3	Repeater Assemblies 214
10.4	Communications Center..... 222
10.5	Communications Center Modifications..... 222
10.6	Repeater Station A Modification 222
10.7	Repeater Station B Modification 222
10.8	Mechanical Modifications 225
10.9	Alternate Monitor Station Modifications 225

Figure	Page
2-1 Plan of Grace Mine Orebody.....	110
2-2 Fan-Hole Drill Operation.....	111
2-3 Load-Haul-Dump Vehicle.....	112
4-1 Hoist Communications System	120
4-2 RF "Leaky-Feeder" Communications System.....	124
4-3 Environmental Monitoring System.....	126
5-1 Inductive Hoist Communications System	128
5-2 Hoist Room Station	129
5-3 Cage System.....	129
5-4 "B" Shaft Double-Deck Cage Being Assembled on the Surface.....	130
5-5 Hoist-Shaft Communications Equipment Installed in Man-Cage.....	131
5-6 Inductive Coupler Mounted Around the Hoist Cable at the Headframe	131
5-7 Inductive Coupler and Rock Shield Mounted Around the Hoist Cable Above the Man-Cage	132
5-8 Hoist Communications Transceiver With Battery and Charger	133
5-9 Hoist Operator's Equipment	133
5-10 "Leaky-Feeder" Cable Runs.....	135
5-11 UHF/VHF Repeater System	136
5-12 Principle of Operation of "Leaky-Feeder"	138
5-13 Basic Cable Equipment	138
5-14 UHF/VHF Repeater Station	139
5-15 Portable "Handie-Talkie"	140
5-16 Mobile Radio	140
5-17 Communications Center Equipment	140
5-18 Alternate Monitor Station.....	141
5-19 Guardhouse Intercom Telephone.....	141
5-20 RF "Leaky-Feeder" Communications System Test Diagram	142
5-21 Radiating Cable Installation on Messenger Wire.....	143
5-22 UHF/VHF Repeater Station "B" as Installed in Crossdrift	144
5-23 Communications Center With Page Encoder	145
5-24 Alternate Monitor Station of Conveyor Operator's Console.....	146
5-25 Intercom Telephone in Surface Guardhouse	146
5-26 UHF Mobile Radio Mounted on Underground Ambulance	147
5-27 Fan-Hole Drill Operator With Noise-Reducing Speaker-Microphone and Belt-Suspended Radio.....	148

List of Illustrations (Cont)

Figure	Page
8-1 Signal Strengths at Discrete Cage Depths	184
8-2 Transmit Signal Strength Mobile to Repeater B.....	185
8-3 Signal Strength at Repeater B From Handheld Portable	186
8-4 Variation in Signal Strength With Antenna Polarization	187
8-5 Receive Signal Strength (Main Haulage) Repeater to Portable/Mobile Zone B	188
8-6 Signal Strength Perpendicular to "Leaky-Feeder" (Cert 875)	189
8-7 Signal Strength Perpendicular to "Leaky-Feeder" (RX5-1R)	190
8-8 Signal Strength Parallel to Drift Containing TV 300-Ohm Twin Lead	191
8-9 Receive Signal Strength (Main Haulage) Repeater to Portable/Mobile Zone B	192
8-10 Transmit Signal Strength (Main Haulage) Portable to Repeater B	193
9-1 Usable Cable Distances	198
9-2 Cable Distribution Model	199
9-3 RX4-1 (1/2-Inch) Basic Cable Distribution Model	202
9-4 RX5-1 (7/8-Inch) Cable Distribution Model	204
9-5 Repeater Link Diagram	207
9-6 "Leaky-Feeder" Cable Distribution Map.....	209
10-1 "Leaky-Feeder" System Block Diagram	215
10-2 Repeater A Station (Sheet 1)	218
10-2 Repeater B Station (Sheet 2)	219
10-3 RPTA Interconnect Wiring	220
10-4 RPTB Interconnect Wiring	221
10-5 Component Location Diagram	223
10-6 Audio Switching Circuit	226

List of Tables (Cont)

Table	Page
8-1 Signal Strengths at Discrete Cage Depths	163
8-2 Transmit Signal Strength (Mobile) (Figure 8-2)	171
8-3 Transmit Signal Strength (Portable) (Figure 8-3)	173
8-4 Receive Signal Strength (Figure 8-5)	177
8-5 Receive Signal Strength (Perpendicular to Coax) (Figure 8-6)	178
8-6 Receive Signal Strength (Perpendicular to Coax) (Figure 8-7)	179
8-7 Receive Signal Strength Fan-Hole Drift (Figure 8-8)	179
8-8 Receive Signal Strength (Figure 8-9).....	180
8-9 Transmit Signal Strength (Portable) (Figure 8-10)	181
10-1 Control Module Complement	216
10-2 Alternate Monitor Station Subassemblies	225

SECTION III
SUNSHINE MINE

	Page
1.0 INTRODUCTION	229
2.0 SUNSHINE MINE DESCRIPTION.....	231
3.0 STATEMENT OF THE PROBLEM.....	235
3.1 Hoist Communications	235
3.2 Telephone Communications	235
3.3 Emergency Alerting System and Backup Communications	236
3.4 Fan and Pump Monitoring	236
3.5 Environmental Monitoring.....	236
3.6 Muck Pocket Communication	237
4.0 SOLUTION AND EQUIPMENT DESCRIPTION.....	239
4.1 Contract Brief	239
4.2 Survey Results	240
4.3 Hardware Implementation.....	241
4.4 Hoist Communications	243
4.4.1 Hardware Description	244
4.4.2 Installation.....	246
4.4.3 Follow-On Maintenance and Support.....	251
4.5 Carrier Communication System	253
4.5.1 System Operation	253
4.5.2 Hardware Description	256
4.5.3 Private Branch Exchange (PBX)	258
4.5.4 Attendant's Console	259
4.5.5 Anaconda S6A	260
4.6 Intercoms	262
4.7 Telephones	268
4.8 Installation.....	269
4.9 Follow-On Maintenance and Support.....	277
4.10 Additional Monitoring and Control Capability.....	279
4.11 System Operation	279
4.12 Hardware Description	282
4.13 Master Stations	282
4.14 Remote Stations	284
4.15 Micro-Master Display	285
5.0 CONCLUSIONS/RECOMMENDATIONS.....	289
5.1 Conclusions	289
5.2 Recommendations	290

Table of Contents (Cont)

	Page
6.0 EQUIPMENT SPECIFICATIONS	293
6.1 Hoist Communication System	293
6.2 Carrier Communication System	294
7.0 PERFORMANCE TESTS	299
7.1 Hoist Communication System Performance Tests	299
7.2 Carrier Communications System Performance Tests ..	302
7.2.1 Tests Performed	303
8.0 SYSTEM COSTS	305
8.1 Carrier Communication System	305
8.2 Monitor and Control System	306

List of Illustrations

Figure	Page
2-1 Sunshine Mine Map	231
2-2 Example of Horizontal Cut-and-Fill Stopping	232
4-1 Hoist Communications System	242
4-2 Block Diagram Showing Transceivers, Couplers, and Rope	243
4-3 HCS-103 Hoist Communications System	244
4-4 Cage Transceiver and Battery as Mounted in Protective Enclosure	245
4-5 Cage Installation at Sunshine Mine.....	246
4-6 Sunshine Mine Cage Installation Wiring	247
4-7 Shaft Inspection	248
4-8 In-Cage Belling Addition	249
4-9 In-Cage Belling Operation	250
4-10 Jewell Chippy Hoist Room Installation	250
4-11 Sheave Wheel Coupler	250
4-12 Open Cage Transceiver Shown	251
4-13 Sunshine Mine Carrier Communications System, Block Diagram	254
4-14 Sunshine Telephone Number List	257
4-15 503 PBX Cabinet	258
4-16 Attendant's Console and Busy Lamp Field	259
4-17 S6A Channel Frequency Allocation	260
4-18 Sunshine Mine Carrier System Central Office	261
4-19 Single S6A Subscriber Terminal	263
4-20 Dual S6A Subscriber Terminal.....	263
4-21 8-Station Intercom	264
4-22 17-Station Intercom	265
4-23 Intercom Station Block Diagram	266
4-24 Intercom Swing-Out Gate	267
4-25 Weatherized Telephone	268
4-26 Weatherized Telephone (Internal)	269
4-27 Rock Burst Monitor Room PBX Installation	270
4-28 Underground Electric Shop Telephone Installation	271
4-29 Shaft Station Subscriber Drop and Intercom Installation.....	272
4-30 Telephone, Intercom, and Carrier Drop Installation	272
4-31 Surface Intercom Installation	273
4-32 Station Telephone Installation	274
4-33 Surface Electric Shop Telephone Installation	274
4-34 System Installation Drawing	275
4-35 Uninterruptible Power Source Installation	276

List of Illustrations (Cont)

Figure	Page
4-36 Corrosion of Underground Klaxon.....	278
4-37 Supervisory Monitoring and Control System Block Diagram.....	280
4-38 Audio Signal Diagram for Monitor and Control System ..	281
4-39 Rock Burst Monitor Room Master Station Assembly	282
4-40 Surface Master and Micro-Master Rack Cabinet	283
4-41 Remote Station Assembly	285
4-42 Micro-Master Telemetry Panel	287

SECTION I

A Communications and Monitoring System for an Underground Coal Mine

Robena Mine

1.0 INTRODUCTION

The Coal Mine Health and Safety Act of 1969 authorized the United States Bureau of Mines to undertake research that would lead to increased safety in mines. This research included the development of new or improved means and methods of communications during normal day-to-day and emergency situations.

This section of the report (Section I) describes the efforts to provide improved communications at the Robena Coal Mine located in southwestern Pennsylvania.

2.0 ROBENA MINE DESCRIPTION

The Robena coal mine is a complex of four connected mines owned and operated by the United States Steel Corporation. The mines are referred to as Robena number one (R1) through Robena number four (R4). The complex is located in southwestern Pennsylvania, Greene County.

The mined product at Robena is low sulfur bituminous coal, from the Pittsburgh seam, approximately 93 inches high. The mine size (figure 2-1) is approximately 7.6 miles North and South by 8.6 miles East and West with overburden from 300 feet to 1000 feet. Entries and haulageways are typically 6.5 feet high by 14 to 15 feet wide. The entries and haulageways follow the pitch of the seam and never exceed 5 degrees.

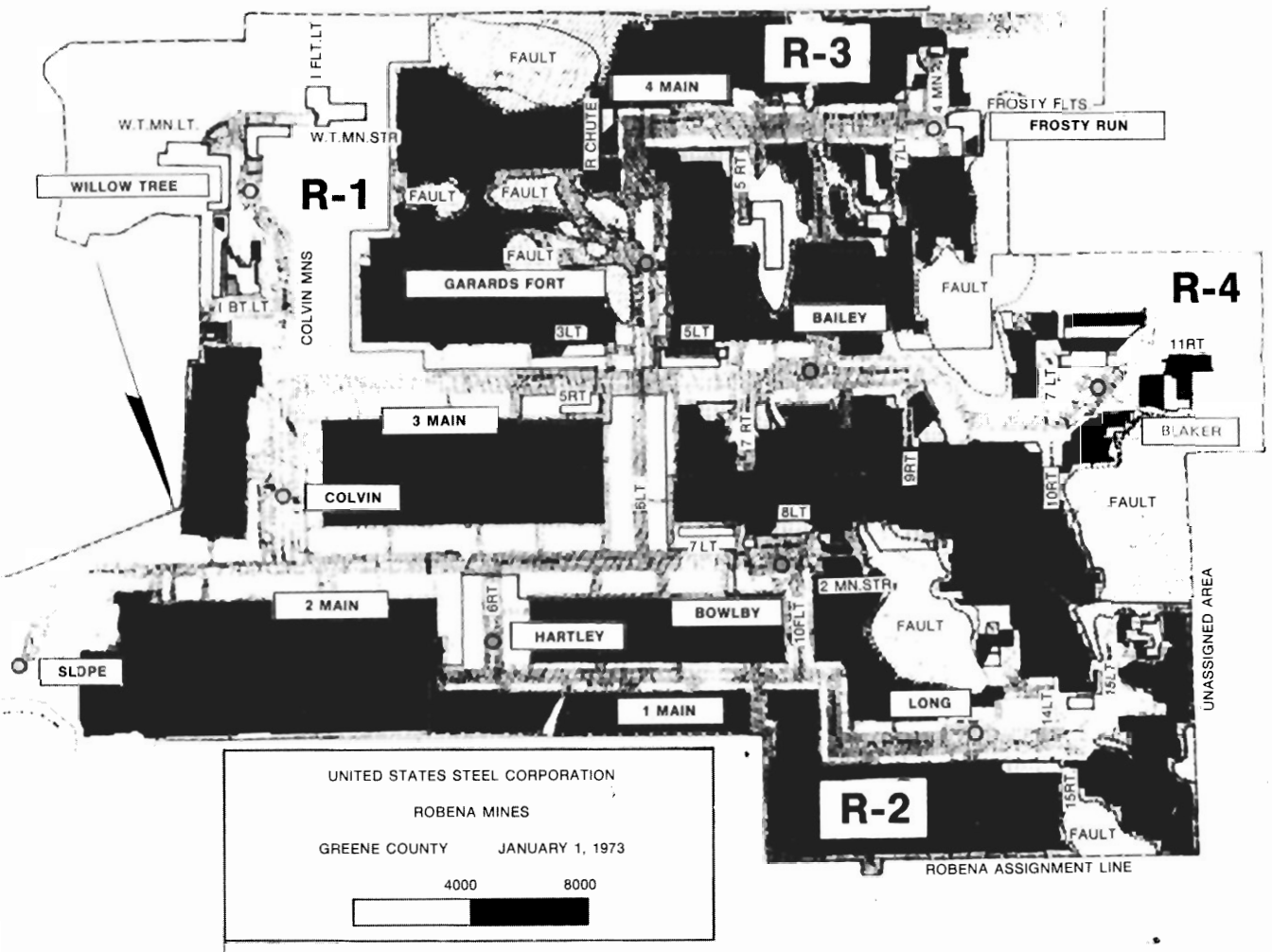

Figure 2-1. Robena Mine Complex.

The coal is mined by room and pillar mining using continuous miners. A mining area is referred to as a "working section" with the following complement of equipment: one continuous miner, two shuttle cars, one roof bolter, and one car puller. A typical working section cycle starts with the continuous miner cutting coal and filling a shuttle car. When the shuttle car is full, the driver moves the coal load to a central location for transfer to one of six haulage cars. A waiting shuttle car meanwhile is being filled by the continuous miner. Once the shuttle car transfers its load, it returns to the continuous miner to repeat the cycle. Excluding mechanical trouble, the continuous miner will cut a block of coal 5 feet high, 15 feet wide, and 16 feet long in one hour. A working section can mine five blocks this size in an 8-hour shift. This yields a total mine production of several million tons per year.

The coal is removed from the face area by shuttle cars and loaded into a set of six haulage cars. As each car is filled, the set is advanced by an electric car puller. When the six cars are full, sets are combined into trains comprised of dual locomotives and 24 haulage cars making the total train approximately 650 feet long. Each car holds 20 tons, making each train load approximately 480 tons of coal. The coal is hauled to a central dumping point where six cars are emptied simultaneously by a rotating drum dumper. The emptied cars are returned to the working sections via a separate dedicated haulageway. In this manner, coal is hauled to the central dump and the empty cars returned to the sections in an efficient and safe procedure.

Vehicle movement is coordinated by dispatchers who monitor the vehicle locations. All rail traffic movement must be authorized by dispatcher, with the exception of local traffic within a section. Signal lights operated by vehicle drivers are used as a further aid in safely coordinating traffic. With the exception of equipment in the working sections, all transportation underground is via trolley-powered vehicles running on tracks. The vehicles include locomotives used for the transport of coal, men and large pieces of material, rock dusters used to periodically rock dust the haulages, and "jeeps" used to transport four to five men with materials for maintenance and inspections.

The coal collected at the rotary dump is removed from the mine through a slope entry via a conveyor belt. On the surface the coal is sized and cleaned at the US Steel owned and operated preparation plant. Waste rock and debris are removed and located at a nearby "slag heap." Properly cleaned and sized, the coal is loaded onto barges for transport via the Monongahela River.

Ten shafts service the mine for air intake and exhaust, and movement of men and materials. Colvin, Garards Fort, and Blaker shafts are the men and materials shafts. The prime power for the mine is 550 V dc brought in on feeder cables. Auxiliary ac power is provided for several of the working sections and accessory equipment. In the mine the trolley wire is run parallel to the feeder cable; equipment requiring power tap onto the trolley or feeder cable at "nip" points.

Water used in the mining process is pumped to a central location for removal to the preparation plant. At the plant the water is used to clean the coal and put into a settling pond. Contaminants settle out and the water is then recycled into the mining process.

Surface facilities, located at several of the access shafts, include office areas, warehouses, machine and repair shops, electric shops, garages, carpenter shops, hoist and compressor houses, bath houses, lumber sheds, storage yards, heating plants, and supply houses.

3.0 STATEMENT OF THE PROBLEM

The communications and monitoring systems at the Robena Mine complex as surveyed under provisions of this program are representative of a coal mine of its size and age.

3.1 Communication System

The communications systems consist of a carrier (or trolley) phone system and a magneto phone system. All vehicles are equipped with carrier phones and all active working sections along with selected underground positions have Western Electric magneto phones. Three dispatchers located at the bottoms of Colvin, Garards Fort, and Blaker shafts provide dispatch service for the mine complex.

Several party-line phone circuits terminate at a simple switchboard in each dispatcher's office. Several telephones are wired in parallel on each of these circuits. Calls between circuits must be made through the dispatcher and his switchboard, whereas calls within a circuit may be placed directly. Each dispatcher is responsible for the telephone traffic and vehicle movement within his jurisdiction. Vehicles passing from one mine to another must contact the applicable dispatcher for that area. Some of the line circuits extend to surface sites, allowing supervisory and maintenance personnel located at the surface to converse with underground personnel. Interconnections can be made to allow communications between mines within the complex.

Since the magneto phone system operates with a bell ringer rather than a loudspeaker, the rings are coded to indicate specific places or individuals. The phones are equipped with dry cell batteries and on/off switches to conserve battery life.

The dispatcher communicates through a single headset, and selection of either the mine phone or carrier phone is made using a two-position switch. Other switches connect and disconnect the various mine telephone circuits. The dispatcher controls all vehicle traffic and serves as a telephone operator. Operator duties include: answering phone calls, switching phone circuits; personnel calling and locating; and taking or relaying messages.

Since the dispatcher is more likely to contact a working section through the motor and an associated carrier phone in that section, the mine phones at the sections are used relatively little compared to the carrier phone. Use of the section magneto phones is primarily limited to outgoing reports by maintenance and production personnel.

A general look at the trolley phone system shows that it works very well indeed -- especially considering the physical, electronic, and acoustic abuse under which it must exist.

In spite of any drawbacks, miners have adapted to the situation and use the trolley phone system very well. During all of the site surveys to the mine it was rare that a repeat was ever asked for on the trolley phone system. No improvements were anticipated for this system.

The telephone system, however, was another situation. The system suffers from excessive noise and distortion and, through the results of telephone surveys, it was determined that the chances of getting a busy signal are 50 times greater than most industries find acceptable. The system is plagued with the problems of broken lines due to roof fractionation and the opening of temporary splices disabling telephones at the extremities of the mine. Interviews with key mine personnel provided the basis for outlining improvement goals for the existing telephone system. These goals are listed below.

The most important communications requirement as defined by the management of this mine concerned safety. They strongly felt that a secure channel was needed where only the persons calling and called could hear the conversation. There are two reasons for this: first, and most important, anyone calling, seeking aid for an injured miner, tends to belittle the seriousness of the injury because he knows that friends and relatives of the injured miner, and those just curious, will be listening to the conversation; (the problem is not unique to this mine) secondly, the phones of these eavesdroppers each load the line to an extent and cause the emergency communications to be impaired.

Because of the limited number of telephone lines used and the heavy usage of the dispatcher for routing calls, it was felt that additional channel capacity was needed. The extra channels would minimize the telephone duties the dispatcher performs and would eliminate the communication system blocking problem. Moreover, additional channels would probably increase the total traffic density.

Also, from observing the mine operation and talking to various personnel, it appeared that section foremen, like the foremen in most industrial operations, were overworked and yet were the key to improving productivity. Therefore wireless communication, whether it be one-way or two-way voice, was needed for at least the section foremen along with various other selected supervisors or maintenance personnel.

From the analysis of the mine and its current communications, it was determined that as a minimum, improvement was needed in the following areas:

- a. Reasonable communication channel signal-to-noise level
- b. Increased number of independent voice channels
- c. At least one secure voice channel for emergency situations
- d. Some form of wireless communication to selected individuals on the working section or roving in haulageways
- e. A communication center
- f. A disaster mode communication system for trapped miners

3.2 Monitoring Systems

The fan monitoring consists of a unique synchronized pulse system multiplexed onto a wire pair and displayed at the Colvin shaft hoist house. The 10 fans associated with the system are monitored on a go/no-go basis, with each location provided with two fans for redundancy. A 4-second pulse is periodically transmitted from each location to the receiver at Colvin. Loss of this pulse will cause the system to trigger an interlock that removes all underground power. The fan initiating the alarm must then be checked by roving maintenance men in order to restore underground power.

The major pumps in the complex are monitored for bearing temperature and pressure, sump level, output pressure, and current drain. A local display is provided for these parameters with automatic shutdown or turn on if certain limits are exceeded. Critical locations are equipped with two pumps for redundancy; one on active status, the second as a hot standby. The power going to these pumping stations is monitored on a go/no-go basis and displayed at the Colvin shaft hoist house. Visual inspection and action by maintenance personnel are required if a failure is detected.

Environmental parameters are checked on a periodic and spot-check basis as required by federal and state laws. The continuous mining machines are equipped with methane monitors that continuously sample the air near the mining machine. If the concentration of methane should exceed a preset limit as defined by regulations, the machine is automatically shut down.

In addition the face and immediate area must be checked frequently with a mine safety lamp and another detection device by the section foreman. The entire mine is checked by a "fire boss" every eight hours for excess methane and adequate airflow. Supervisory and maintenance personnel also perform spot checks of these same parameters in their daily routine. Dust samples are collected every 120 days on a cross section of the miners and every 90 days on high risk miners (that is, those miners who perform in a capacity that, by the nature of their jobs, contains a high level of dust). Detected problems are reported and immediately corrected.

Because of the time involved in gathering and the inadequacy of the information, it was felt that the monitoring at Robena could be improved in the following areas:

- a. Provide fixed location monitoring of methane (CH₄), carbon monoxide (CO), and air velocity (AV) in selected haulageways and returns.
- b. Provide monitoring of air velocity, differential pressure, on/off status at ventilation fan sites
- c. Provide fire monitoring along main haulages
- d. Monitor various underground power feeds
- e. Monitor critical pump status; that is, bearing pressure, sump level, and on/off
- f. Remote all monitor information to a central surface display where the data could be reviewed by mine management.

3.3 Hoist Communication

Two of the men-and-materials shafts are equipped with standard pushbutton-operated elevators. These shafts, therefore, have no need of hoistmen. The other shaft does not share this feature and therefore is troubled with not having direct communication between the personnel on the cage and the hoistman operating the system. The hoisting operation at these shafts is controlled by two men relaying commands to the hoistmen, the top man, located at the shaft top; and the bottom man, located at the shaft bottom. Both men assist in the loading and unloading of the cage, and direct the hoistmen when to raise or lower the cage. The communication between the top-man/bottom-man team and the hoistmen is via bell and light signals. This procedure works quite well for normal operations; however, during daily shaft inspections a man must ride on top of the cage and inspect the shaft walls as the cage is lowered. Control of the cage position is by relayed messages from the man on top of the cage to a man at the shaft top to the hoistman using a police-type whistle. This method is slow and often results in misunderstood messages. Citizen band transceivers were also tried but with little success. The need for direct communication between a man on the cage and the hoistman was desired.

4.0 PLANNED SOLUTION

Adequate communications within a mine and to the surface is a vital part of the proper operation of an underground facility. This communication capability is not only an important factor in the concept of safety precautions, but also is an aid to the day-to-day operations.

In a like manner, a judicious choice of monitored parameters of the underground environment and selected machinery will yield a cost savings in production and augment safety. Many man-hours and material dollars can be saved by knowing conditions before they become a problem. Situations that could be disastrous can be predicted and proper solutions implemented before a problem occurs. Proper environmental and machine monitoring is the key to safer, more productive underground mining.

4.1 Contract Brief

The problems associated with the communications and monitoring systems (or lack thereof) in the Robena Mine Complex were described in the previous section. The solutions as devised under provisions of the USBM Engineering and Administrative Services Contract SO133035 and JO377076 were implemented in accordance with the following program:

a. Communication Survey

1. Determine the communication and monitoring requirements for the mine in conjunction with the USBM Technical Project Officer (TPO) via site surveys and personnel interviews
2. Provide an itemized list of the communication and monitoring requirements and submit this list to the USBM TPO

b. Whole Mine Communication/Monitoring Systems

1. Prepare drawings showing equipment selection, location, and installation details and submit to the TPO
2. Prepare a final technical report on the recommended systems solutions to the approved list of communication and monitoring requirements
3. Prepare system block diagrams and lists of materials for installation at the mine
4. Review equipment locations and installation details with mine personnel
5. Coordinate USBM purchase of all recommended equipment

c. Prepare Equipment Procurement

1. Write specifications on individual equipment and subsystems to serve as procurement documents
2. Prepare procurement lists and submit to TPO
3. Assist USBM in procuring recommended equipment

d. Equipment Acceptance

1. Prepare "inspection checklist" to serve as a guide for receiving equipment and components purchased
2. Prepare a "calibration and test checklist" using specifications and manufacturers' information

3. Perform incoming inspection on all equipments as they arrive at Rockwell-Collins, Cedar Rapids, Iowa
 4. Perform initial electrical tests on equipment as it is received, documenting the results
 5. Assemble subsystems
 6. Calibrate and align all equipment
 7. Review test reports for inclusion into a permanent log book record
 8. Perform final systems integration tests to ensure that all subsystems have been interconnected correctly
 9. Demonstrate final system tests to the USBM TPO at Rockwell-Collins, Cedar Rapids, Iowa, test facilities
- e. System Installation
1. Review installation plans with the mine and USBM personnel
 2. Ship all subsystems to the mine
 3. Assist the mine in installing the systems
- f. Maintenance Training Program
1. Prepare an operations and maintenance training program for mine personnel
 2. Conduct sessions at the mine on the minor repair and routine maintenance of all equipments installed
 3. Coordinate the attendance of technicians from the mine and manufacturer's schools
 4. Review system operation and maintenance problems, recommending corrective action
- g. Make System Operational
1. Prepare a systems log book to be used by mine personnel for recording systems maintenance performed
 2. Identify test points for the systems in a manner and format consistent with the log book
 3. Determine acceptable test limits and methods for routine maintenance on equipment
 4. Prepare a test plan and a coordinated schedule for a system operation demonstration
 5. Perform "called-for" acceptance tests and demonstrate system to USBM and mine personnel
- h. Field Support and Modification
1. Provide "follow-on" support as required to modify and maintain the system after acceptance of the installation
 2. Document modifications performed and periodic systems tests

4.2 Survey Results

The communication and monitoring survey results at the Robena Mine Complex indicated a need for new or improved communications and monitoring capability in the following areas:

- a. Reasonable communication channel signal-to-noise level
- b. Increased number of independent voice channels
- c. At least one secure voice channel for emergency situations
- d. Some form of wireless communication to selected individuals on the working section or roving in haulageways

- e. A communication center
- f. A disaster mode communication system for trapped miners
- g. Fixed location monitor of selected parameters in haulageways and returns
- h. Monitor fan status
- i. Fire alarm monitoring along main haulages
- j. Monitor pump status and power feeds
- k. Remote monitor information to a central surface display
- l. Hoist communications for shaft inspections

4.3 Proposed Solutions

4.3.1 Communication and Monitoring

The telephone and trolley phone systems installed at Robena, and at many other coal mines, provide for vital operational efficiency. The coal industry in general has recognized this, and has accepted amplified telephone equipment that extends the selective area ring into individual paging and provides communications to the mining section. The industry has also accepted the trolley phone, an ingenious device that aids in expediting rail haulage.

However, through the efforts of this and several other United States Bureau of Mines sponsored programs, it was determined that general mine communications must encompass post-disaster rescuing, environment monitoring, and day-to-day communications as an integrated whole.

In an ideal system an individual must be able to initiate and receive calls as necessary, regardless of his location within the mine. To accomplish this a group of semiautonomous subsystems are required. A basic fixed intramine phone system is used, along with vehicular and hoist communication systems, and is integrated into a single functional system. System operation should be as familiar to the user as possible, with a goal of operating like the public phone system. The system should also provide a two-way communication path for post-disaster situations.

Studies of operating mines showed that fixed intramine communications equipment requires a 6- to 20-channel capacity. The number of channels required in such a minimum system is related to size of mine, number of working sections, and desire to include vehicles as part of the overall system rather than as isolated elements. If an entire mine, including the surface complex, is integrated into a single system, more channels are required. Underground areas require 6 to 10 of the operating voice channels, while the extent of the surface communications and data transmission determines the total number of channels necessary.

A communications center should be established with two fundamental requirements. First, the center must be flexible and expandable to accommodate growth with the mine. Second, the communications center should be located on the surface with multiple signal paths to underground areas. This location provides an environment more conducive to maximal output from both the center and its operator, which in the long run offsets the cost of an outside location. The communications center must be economically expandable from a simple monitoring operation by a lamp man or hoist operator to a complex data center having a full-time operator as mine size increases. Besides serving as an information center, the communications center must be flexible enough to interconnect the various networks and to serve as a broadcast center for full coverage announcements to all mine personnel.

Interface requirements for alarm and monitor systems are simply that they be compatible with voice grade communication distribution systems. Economics dictate that alarm and

monitor sensors utilize communications networks for the transfer of data to the monitoring centers.

A mine presents a uniquely harsh environment in many areas. Equipment will receive harsh treatment when in operation. Rock dust and/or coal dust will pack in and around all exposed surfaces and crevices. High humidity and dripping water will erode surfaces. The moisture may be corrosive. The equipment must be designed to operate under all these conditions.

Summarizing these requirements for a communication and monitoring system that fulfills the needs of Robena and consequently many other coal mines, yields the following list of specifications:

- a. A disaster mode communication system which also provides routine, operational two-way voice communication
- b. Six to twenty independent voice channel capacity
- c. Secure channel for reporting and seeking aid for an accident victim
- d. Capable of providing continuous monitoring of various environmental parameters
- e. Capable of remotely controlling various mine machinery or processes
- f. Communication center located on the surface for monitor display and central control
- g. Utilization of available conductive media within the mine for transmission of voice and monitor data
- h. Rechargeable battery backup of underground equipments that are trickle charged from power on the telephone lines
- i. Some form of interface with wireless communication to selected individuals on the working sections or roving in haulageways
- j. Multiple or loopback paths to and from the communication center to telephone and monitor locations
- k. Complete coverage of both surface and underground sites with telephone service
- l. Interconnection with landline telephone systems

Research of the market for an off-the-shelf communication system that exhibited the aforementioned characteristics revealed that part of the specifications could be met through the integration of various existing subsystems. The entire system, however, was not available nor readily producible. The decision was thereby made, based on this information, to investigate the possible development of a composite system that did fulfill these requirements. Possible manufacturers were researched, and it was determined that an adaption of an existing Rockwell-Collins product would demonstrate most of the required features plus considerably more. This product is the ATX-101*, a computer based telephone exchange primarily developed for organizations requiring telephone communication for medium to large groups, with suitable interconnection (trunks) to outside landlines. Nearly 300 independent, nonblocking channels provide voice and data paths on two frequency bands. Additional data paths are also provided for monitor and control information.

Telephone communication via the ATX-101 is made possible by using a frequency-division multiplex (FDM) technique that is executed under computer control. Use of the FDM technique permits telephone communication for the entire installation to take place on a single coaxial cable. In addition, the system allows several other features, such as various types of television distribution, expandability, flexibility, easy installation, and reliability.

*Reference to specific brands, equipment, or trade names in this report is made to facilitate understanding and does not imply endorsement by the Bureau of Mines.

The total communication capability provided by a coaxial cable system is the logical answer to a large internal communication and monitoring need. The basic advantage of a coaxial cable system is its ease of expansion and the ability to add new features as future needs arise.

The ATX-101 system as it existed at the onset of this program met the requirements of items b, e, f, and l listed previously. By making use of technology gained through various USBM programs, the ATX-101 could be modified to include all of the aforementioned features with the exception of item g. The constraint of utilizing existing conductive media in the mine for voice and data transmission could not be fulfilled because of the distribution technology required for the ATX-101. Based on this information, it was decided to modify the basic ATX-101 system, designing new hardware where required and packaging equipment for the underground environment, if necessary. This modified system would be the means of improving the communications and monitoring for the Robena Mine Complex as well as providing a system useful to the whole mining industry. The modification would be carried out under provisions of USBM Contract SO346089.

As previously mentioned, items b, e, f, and l could be accomplished by a basic ATX-101 (item g was deemed unfulfillable using the ATX-101). It was therefore necessary to design new hardware or modify existing hardware to satisfy the constraints of the remaining specifications.

Interviews with USBM and mining personnel, in conjunction with information gathered from USBM sponsored efforts, led to the design of an Underground Communication and Monitoring Unit (UCMU), later renamed an underground telephone. This underground telephone would become the basic building block of the modified ATX-101 system. The underground telephone started with the basic technology of the ATX-101 telephone and added a data interface for monitor and control with a local display of these parameters, a through-the-earth voice frequency (VF) emergency/paging transmitter for selective paging and disaster mode communication, rechargeable battery backup, and environmental packaging. The basic ATX-101 telephone was considered adequate for most surface applications.

Additional effort included the new design or modification of the following equipments:

- a. Environmental monitors - the design of a three-function (CO, CH₄, and air velocity) monitor with preset trip points for use at sections and in returns, and the design of a fire monitor with preset trip point for use as a detector in haulageways. Both monitors would receive power from and relay data through telephones to which they are attached.
- b. Monitor/control devices - the design of units to be used for monitoring and controlling various mine machinery (that is, pumps, fans, etc). These devices, like the environmental monitors, would receive power from and relay data through the telephones to which they are attached.
- c. Page receiver - the design of a selective pocket pager that could be carried by section and roving mine personnel. The pager would respond via one-way signaling to page codes transmitted by the VF transmitter in the underground phone.
- d. Monitor display - the development of a display system located within the surface system center to display monitor/control information.
- e. Escapeway receiver - the design of a device used in conjunction with the underground telephone to receive through-the-earth voice transmissions from the surface. To be used primarily during post disaster situations for communication with trapped miners.
- f. Cable distribution equipment - the development of specialty equipment used underground for the coaxial cable distribution network (plant). This included ruggedized line (trunk) amplifiers for signal boosting, telephone taps for individual telephone hookup to the main cable, and weatherized power supplies for powering underground equipments via the coaxial cable.

- g. Test equipment - the design of a portable instrument used for testing underground telephones and cable plant.
- h. Computer programming - the development of computer programming (software) that would allow the additional features to be implemented into the system, (that is, all-call and selective paging, environmental monitor and control with designated display, and diagnostic subroutines). The basic ATX-101 software was modified to implement these functions.
- i. Loop-back - the planning of an overland microwave loop-back as a redundant path for the cable plant. Early in the program, problems were encountered with the interfaces for the microwave equipment and the overland loop-back method was abandoned in favor of an underground coaxial cable loop-back scheme.
- j. Wireless interface - the development of an interface that allows two-way voice communication between any telephone in the system and a miner equipped with a uhf portable transceiver. This effort was accomplished under provisions of USBM Contract HO357155.

The result of all these modifications and additions to the ATX-101 used for Robena (and subsequently other coal mines) was the renaming of this system to be the MCM-101 or Mine Communication and Monitoring System.

The initial complement of equipment installed at the Robena Coal Mine complex included the following:

- a. System center
- b. One set of modified software
- c. Twenty-four surface telephones
- d. Forty-eight underground telephones
- e. Thirty fire monitors
- f. Six three-function monitors
- g. Six escapeway receivers
- h. Twenty-four pocket pagers with two chargers
- i. Five portable test sets
- j. One lot of cable distribution hardware

The wireless interface, monitor/control devices, monitor display, and loop-back interfaces were added at a later date as a modification to USBM Contract SO346089. Figure 4-1 shows the basic operating concept for the proposed communications and monitoring system.

4.3.2 Shaft Hoist Communications

To improve the communication between the hoistmen and the shaft inspector on the cage during daily shaft inspections, an improved version of a hoist radio system installed at the Grace Iron Ore Mine under provisions of this same program was proposed (figure 4-2). The Colvin shaft was selected to demonstrate the concept of hoist communication for these shaft inspections. The Colvin shaft is the shaft with the most active use. This system uses inductive coupling to the cage cable and provides the following performance characteristics:

- a. Narrow-band FM operation
- b. 12-v dc battery operation
- c. Receive sensitivity of 10 microvolts for 20-db quieting
- d. Recessable into the cage wall
- e. Crystal frequency control with stability of ± 0.25 percent of the assigned center frequency
- f. 52-kHz operation

This equipment was produced under provisions of USBM Contract HO357148.

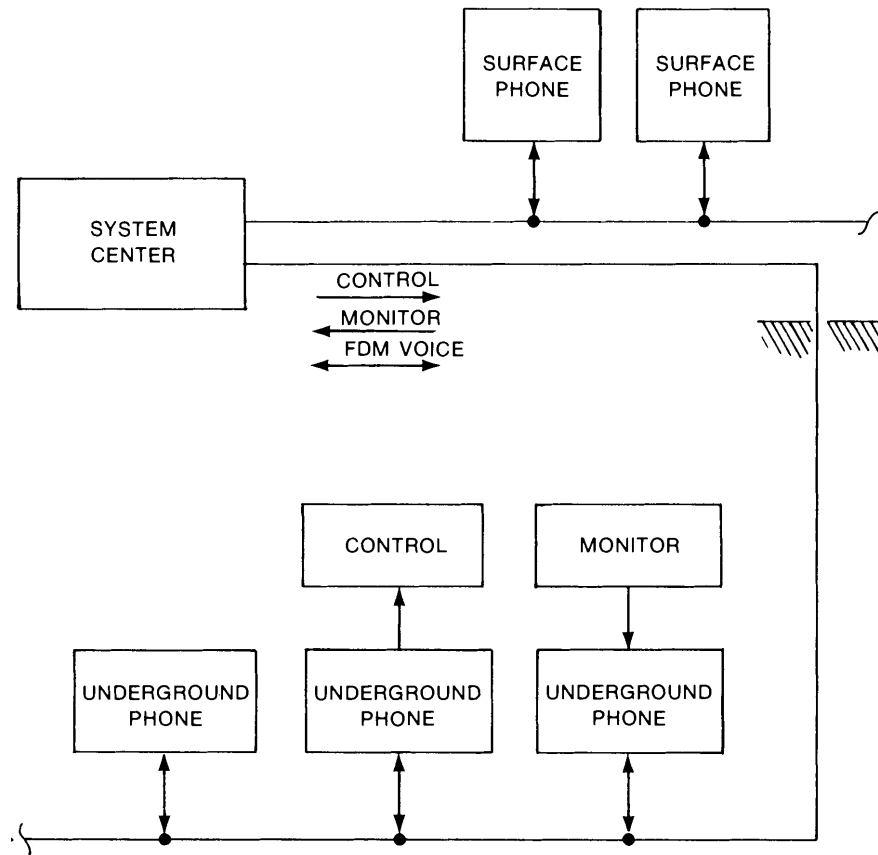

Figure 4-1. Concept of Operation for Proposed Communications and Monitoring System.

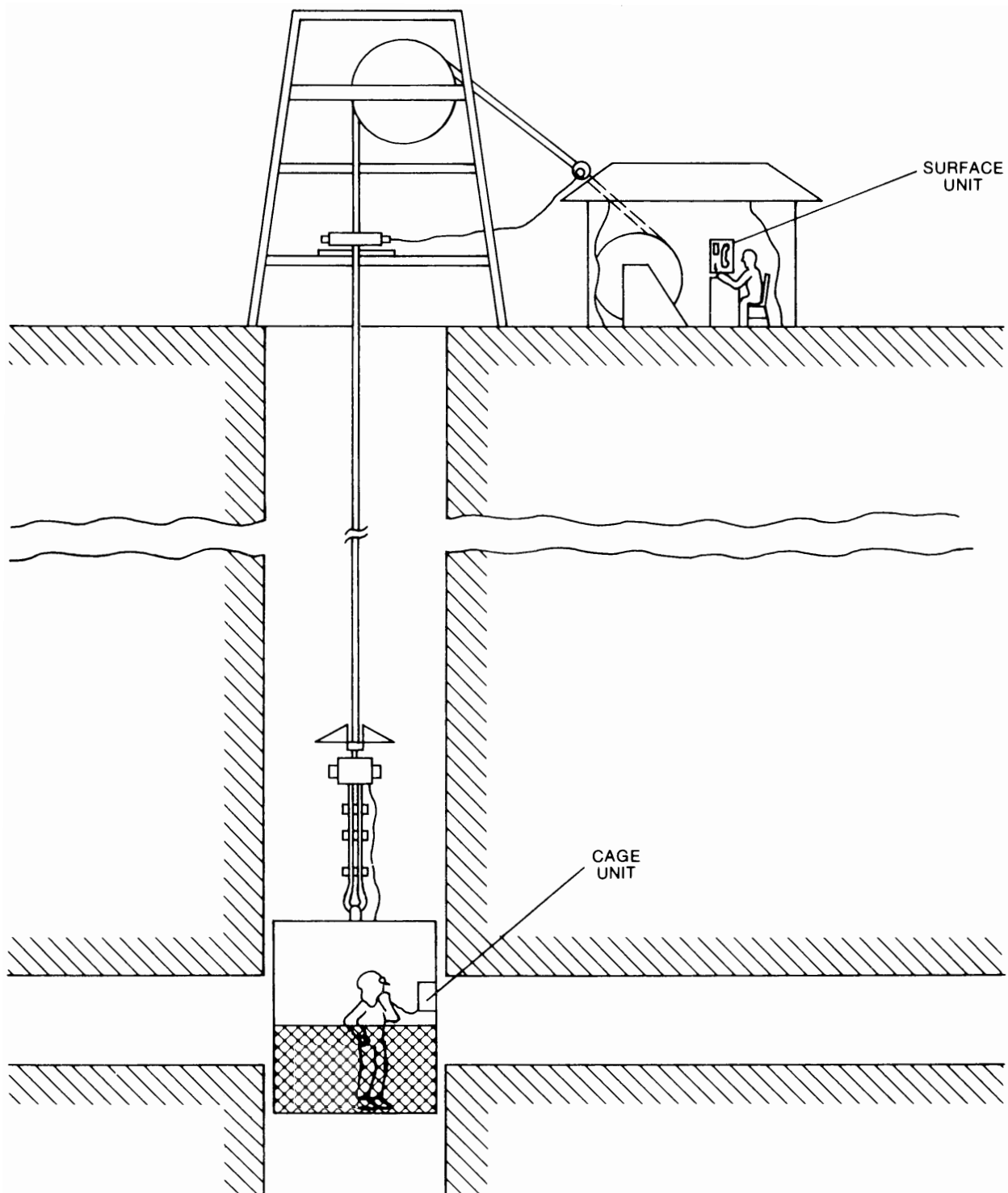

Figure 4-2. Hoist Communications System.

5.0 HARDWARE IMPLEMENTATION DESCRIPTION

The objectives of this program were to provide improved communications and monitoring to the underground environment and between the surface and underground. Specific improvements were to include: increased number of nonblocking channels; a secure channel for emergencies, paging of roving miners; environmental monitoring; control of fans, pumps, or other devices; through-the-earth post disaster communication; a communication center; redundant signal paths; and proper communications between the man on the cage and the hoistman during shaft inspections.

As described in section 4.0, Planned Solutions, the systems selected to fulfill the communication and monitoring requirements of the Robena Mine complex were a modified FDM coaxial cable, communication and monitoring system and an inductive hoist communication system. Both systems were developed or modified for the United States Bureau of Mines. The implementation of the communication and monitoring system will be discussed first.

5.1 Communications and Monitoring

An integrated communication and monitoring system was developed for the United States Bureau of Mines for underground mines. This system is an adaption of a system that is used by organizations requiring telephone communication for medium to large groups. The modified system allows private telephone channels, environmental monitoring, and control of underground equipment, all on a single coaxial cable. All system operations are under the direct control of a dedicated minicomputer. Many advanced features are incorporated into the system, such as paging to roving personnel, two-way wireless interface, through-the-earth emergency communication, and redundant signal paths. Additionally, the coaxial cable may be used to distribute other transmissions such as closed circuit television. The new hardware development and equipment modifications required to formulate this system were provided under USBM Contract SO346089. Production of the system components used to satisfy the communication and monitoring needs of the Robena Mine complex was also covered under this contract.

A single coaxial cable was installed throughout the mine with various branches for distribution. This cable carries both radio frequency (rf) signals and direct current (dc) power. The rf is an FDM signal that carries the communication, monitoring, and control signals to the in-mine devices that are connected to the cable by special taps. On-line amplifiers are used to overcome cable attenuation losses. The dc current, which is provided by several surface power supplies, is used to charge batteries located in all underground devices. These batteries ensure that the system will remain operational even if the main power is lost.

The heart of the system, the system center, is located on the surface. It consists of a minicomputer, various interface and control circuits, power supplies, a teleprinter (TTY), and a monitor display matrix.

Through a cooperative agreement between United States Steel Corporation and the United States Bureau of Mines and under provisions of USBM Contract SO133036, the aforementioned communication and monitoring system was installed, tested, and demonstrated at the Robena Coal Mine complex. Collins Commercial Telecommunications Division, Rockwell International provided the technical expertise to develop and test the system at its Cedar Rapids, Iowa, plant and to coordinate the installation and follow-on support.

5.1.1 System Operation

The communication and monitoring system developed for use at the Robena Mine complex is based on FDM techniques and CATV-type cable distribution. Figure 5-1 depicts how system elements are connected on the coaxial cable, and figure 5-2 shows the way the cable bandwidth is allocated for the various functions shown in figure 5-1.

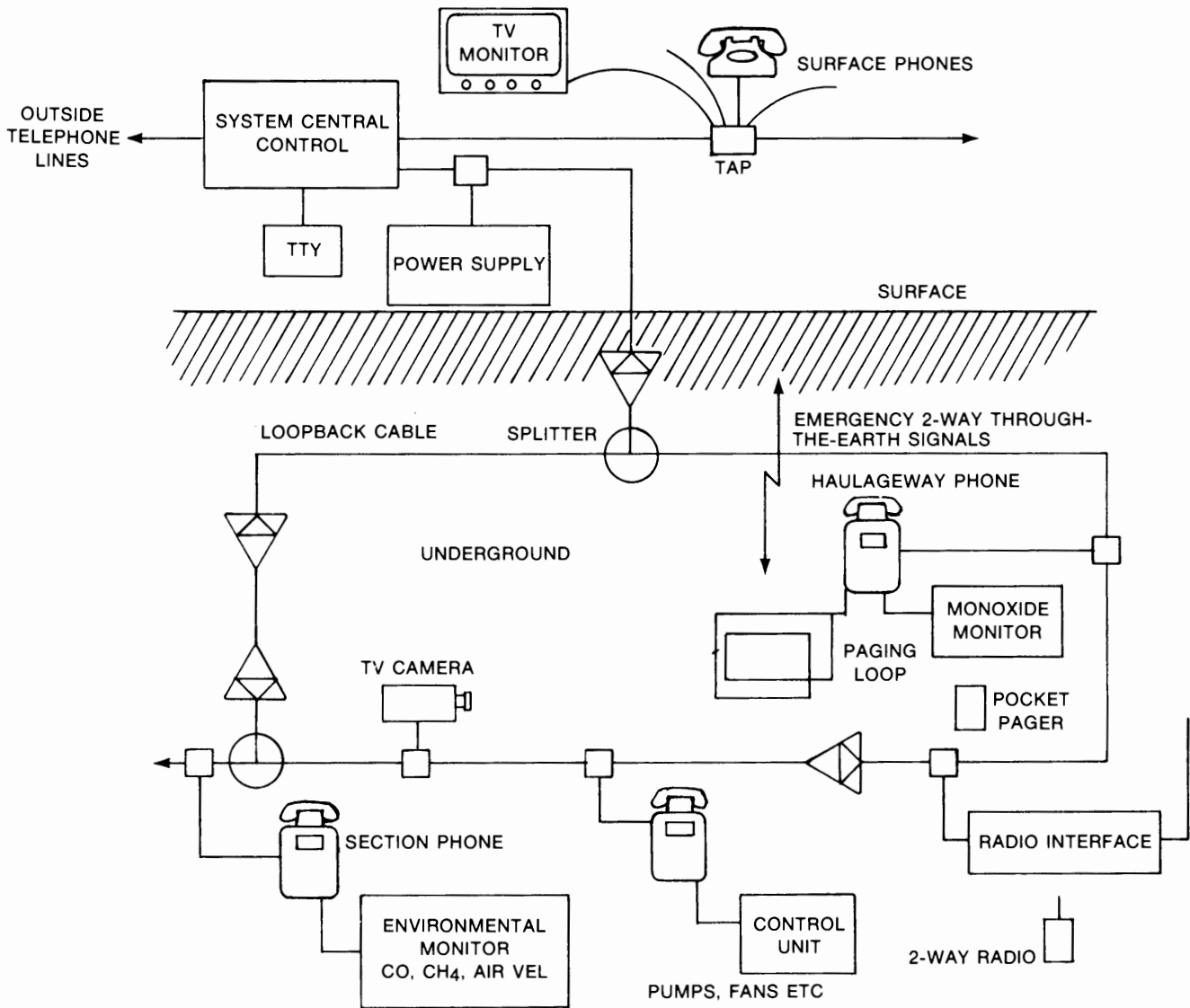

Figure 5-1. Functional Block Diagram of Whole Mine Communication and Monitoring System.

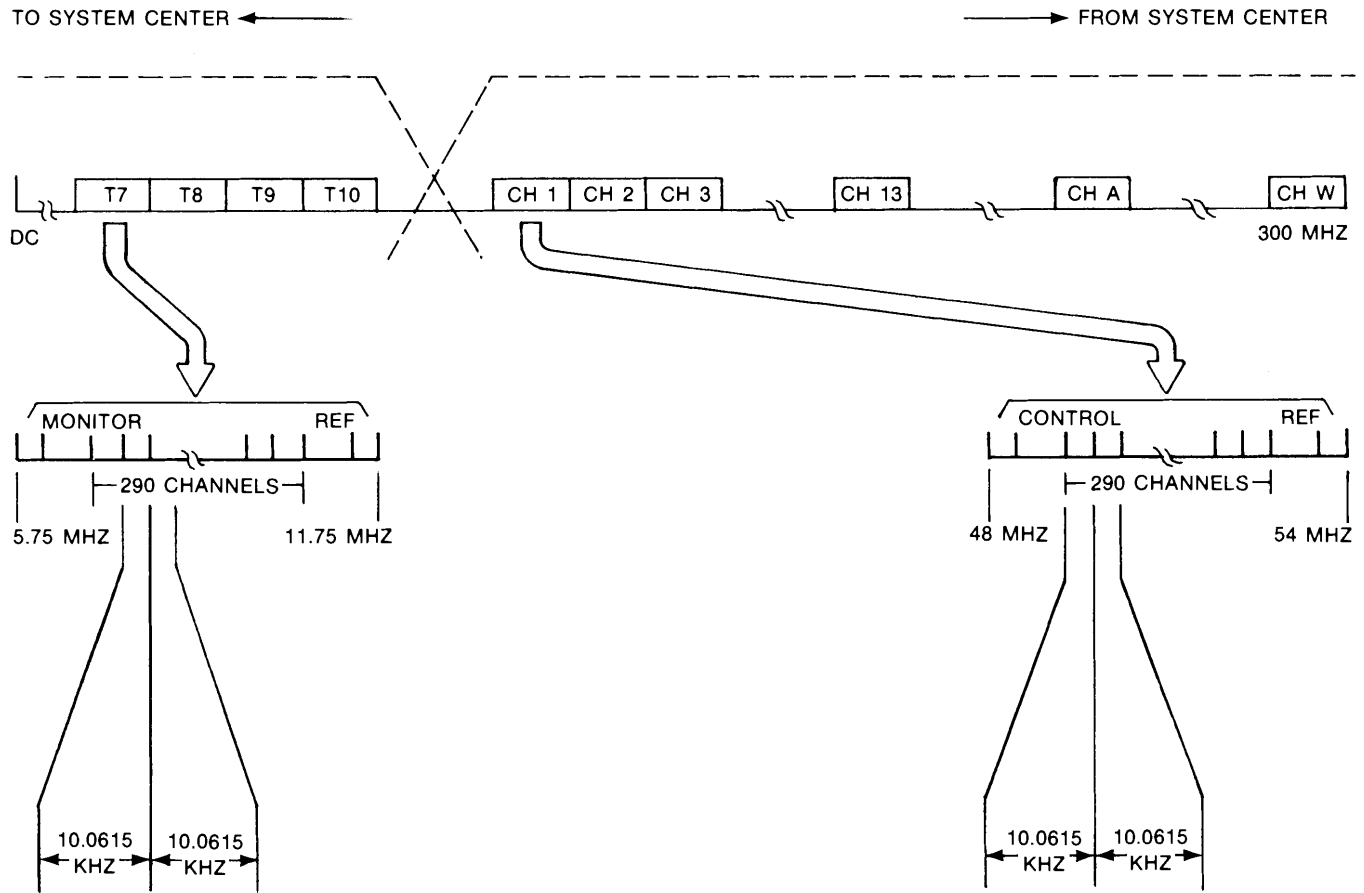

Figure 5-2. FDM Frequency Spectrum and Allocations.

The total cable bandwidth is divided into two blocks of frequencies, such that any transmission into the system center is in the frequency range from 5 to 30 MHz and any function out of the system center is in the range from 48 to 270 MHz (48 to 108 MHz underground). Frequencies used directly by the system are in the T7 (5.75-11.75 MHz) and channel 1 (48-54 MHz) bands. System operation includes call processing by the system center equipment, subscriber operation of the telephone sets, outside line (or trunk) features, operation of the paging system and radio interface, monitor/control display, and fault detection and display. These basic functions are described in the paragraphs that follow.

5.1.1.1 System Center

The system center provides the control function for the entire system. Much like the central office of the public telephone system, the system center is responsible for establishing the desired communications and monitor/control paths. Additionally, the system center is continually checking the operational condition of the equipment, that is, if a phone or monitor/control unit has been removed from the line or has failed. The system center also houses the necessary interface for the outside telephone line connection and the monitor/control display matrix. In normal system operation a polling/interrupt scheme detects subscriber (telephone device) activity and sends these work requests to the appropriate process functions via the computer program.

5.1.1.2 Telephones

For voice communications, all telephone instruments talk on one of 290 voice channels within channel T7 and listen on one of 290 voice channels within channel 1. Processor (minicomputer software) control and monitoring of voice communications and telephone features are accomplished by serial digital data on 80-kilobit data channels within TV channels T7 and 1.

Each telephone instrument is a complete tunable single-sideband transceiver, the operating frequency of which is assigned by the system center. This assignment occurs whenever a phone goes off-hook. The sequence for establishing a call between two telephones is as follows:

(Assume A wants to call B)

- a. A goes off-hook. During the process of polling, (processor asking for data from telephone devices) the processor senses "off-hook" (request for service) via the return control channel and returns a control word to A, which tunes A to the dial tone channel. (Information tones; that is, dial, busy, etc, are generated at the system center and strapped to dedicated FDM channels.)
- b. Upon receipt of dial tone, the user at A dials B's extension number on the dial pad.
- c. Upon receipt of the extension number from A, the processor does the following:
 1. Verifies that the number is a valid number. If not valid, A is sent a control word that tunes A to the invalid tone channel.
 2. Determines that an FDM channel is available. If not, A is tuned to the busy tone channel.
 3. Determines whether B is busy (off-hook). If B is busy, then A is tuned to the busy tone channel.
- d. If the number is valid, a voice channel is available, and B is not busy, then A is tuned to the ringback tone channel and a one-bit ring instruction is sent to B, which energizes the buzzer in the B terminal.
- e. When B answers (causing the off-hook condition to be transmitted back to the processor), the processor sends control data words to A and B causing each to be tuned to an available channel, and normal voice communication is established.
- f. Whenever one of the phones goes on-hook again, transmission from both phones is disabled and the off-hook phone is tuned to dial tone. This frees the voice channel for assignment to another connection in the system. When the remaining phones go on-hook, it is also returned to the idle (nonbusy) condition in the software status tables.

In addition to the basic private-line capability, several convenience features are incorporated into the system operation. These include call forwarding, add-on conferencing, party-line, consultation hold, busy override, self-test, and call trouble identification. The use of these features is assigned to designated telephones via teleprinter class marking commands. In this manner certain features can be restricted to dispatcher or supervisory telephones; that is, party-line for dispatcher telephones wherein all calls to dispatchers override existing calls for emergency situations, and busy override for selected supervisor telephones wherein they can break into ongoing conversations. The self-test and call trouble identification features are used as an aid to telephone failure reporting. All features are under command of the processor and are actuated by dialing selected access codes on the telephone dial pad.

5.1.1.3 Monitor/Control

Monitor and control devices attached to underground telephones provide the user with the ability to remotely monitor the status of certain environmental parameters and to monitor and control selected equipments. The parameters include air velocity, methane, and presence

of fire (carbon monoxide). The environmental parameters or equipment status conditions are continually monitored and any time equipment status changes or preset environmental parameter limits are exceeded, the information is relayed via the data link in the telephone to the system center. In the system center the monitor data is displayed by the display matrix and the teleprinter. The environmental parameters are also displayed locally at the telephone. To initiate a control function, commands are generated at the display matrix and transmitted via the data link to those telephones with control units attached. These control units are used to activate (or shut off) pumps, fans, etc.

5.1.1.4 Paging System

The paging system provides the user with two functions; personal paging and emergency through-the-earth signaling. The emergency/paging transmitters (contained in each underground telephone), pocket pagers, escapeway receiver, and 400-foot loop antennas (attached to each underground telephone), make up the paging system (figure 5-3).

In the personal paging mode, the paging system enables telephone users to initiate pages to specific personnel. This is accomplished by dialing in the number 7 followed by the 3-digit page number of the specific person/pocket pager desired. The system center responds to this page command by sending an encoded message to each underground phone. The emergency paging transmitter transmits this encoded message via the 400-foot loop antenna.

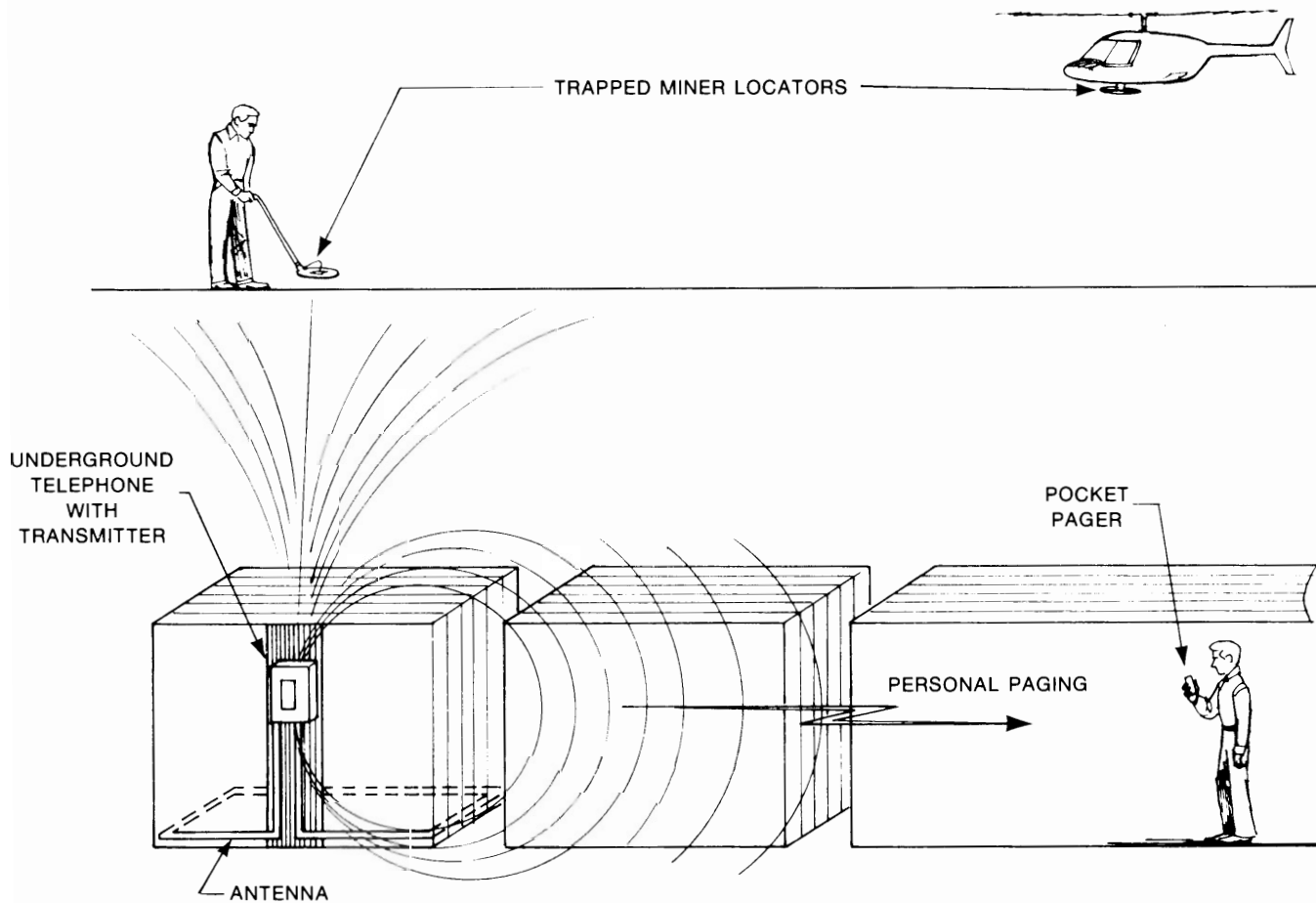

Figure 5-3. Paging/Emergency System.

The pocket pager user receiving the page goes to any telephone in the system and dials in the character number and the 3-digit page number of his pocket pager. The system center responds to this command by automatically calling the phone from which the page was initiated. The page will be automatically canceled if it is not answered in 15 minutes. Selected phones in the system also have the ability to initiate an all-call page to all active pocket pagers, by dialing in the number 7000. This feature is useful for notifying personnel during a mine-wide emergency.

In the emergency mode, the paging system provides through-the-earth signaling. This mode must be manually selected on the emergency/paging transmitter by a switch on the front of the telephone, presumably by a trapped miner. In this event, the emergency/paging transmitter starts transmitting a signal at a preselected emergency frequency and duty cycle. This signal can be detected at the surface, through the overburden, by the use of special receivers. Once located, a trapped miner at the transmitter can communicate with the surface by overriding the preselected transmission with pushbutton keying of messages. Underground telephones equipped with optional escapeway receivers can also hear voice or tone transmissions directed from the surface. The transmissions at the surface are accomplished by deploying a 1000-foot loop antenna and driving it with a high-powered audio amplifier. A two-way communication path is thus established.

5.1.1.5 Radio Interface

The radio (or coupler) interface provides interface between the communication and monitoring system and an ultrahigh frequency (uhf) transceiver communication system. The coupler interface consists of an antenna, repeater, and interface circuitry and can be attached to the coaxial cable at any tap (or port).

A telephone user can contact a portable transceiver (assuming the transceiver is within range of the coupler interface) from any surface or underground telephone by dialing the phone number assigned to the coupler interface. The system center switches the telephone and the coupler interface to an available channel on the coaxial cable and a voice connection between the phone and repeater is established in a normal manner.

A portable transceiver user can access the communication system (assuming the transceiver is within range of the coupler interface) by keying his transmitter three times in rapid succession. This causes the system center to switch the coupler interface and a predefined telephone to an available channel on the coaxial cable distribution system. Once communication between the portable transceiver user and the predefined telephone has been established, the call may be transferred from that phone to any other telephone in the normal manner.

The uhf transceiver system operates as a normal portable-to-portable system (via the repeater), giving extended coverage at its location. The system also operates from portable to portable directly but over a smaller coverage area than when used with the repeater. Under normal conditions the system is powered from the main coax but under power shutdown situations the unit will operate on self-contained battery power for 8 hours with a 20-percent duty cycle.

5.1.1.6 TV Monitor System

The TV monitor system is composed of a TV camera, modulator, converter, TV monitor, and assorted interconnect hardware (figure 5-4). The TV camera and modulator are located at an underground site, monitoring loaded coal cars. The signal from the camera is converted to channel T9 and transmitted via the coaxial cable distribution system to the system center. At the system center, channel T9 is stripped off, up-converted to channel 5 in the converter

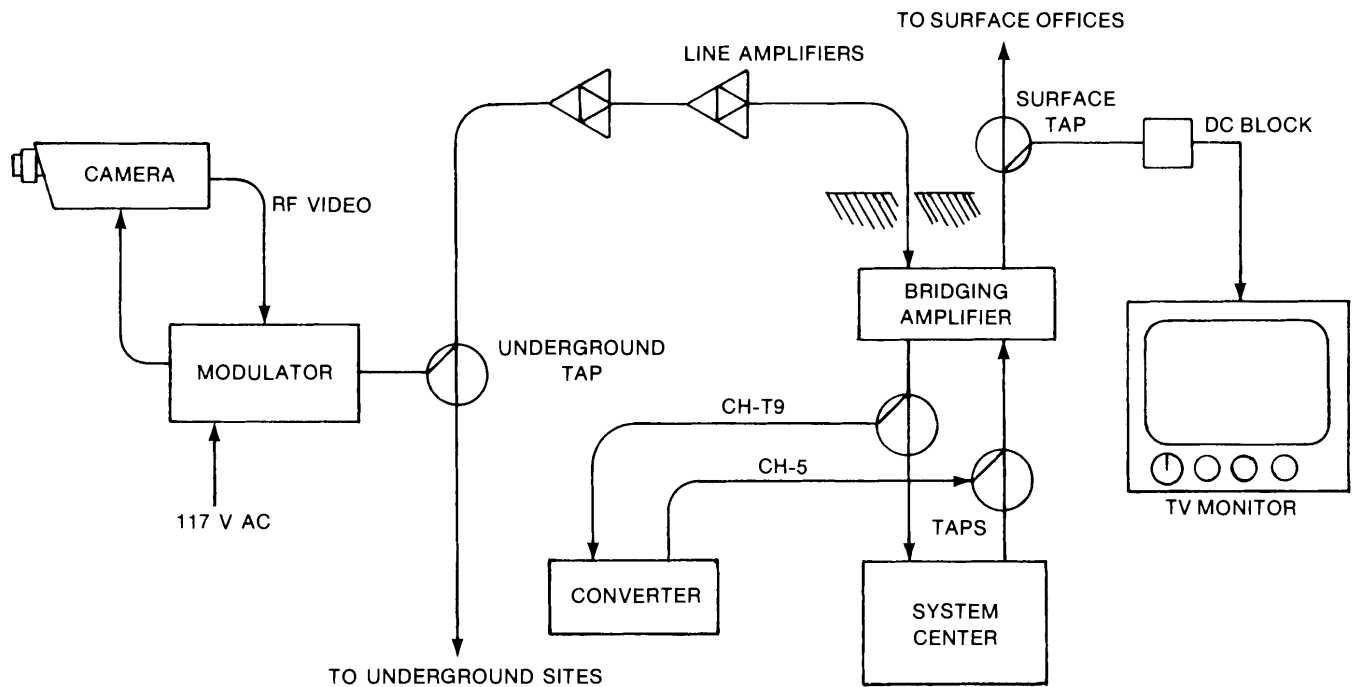

Figure 5-4. TV Monitor System.

and retransmitted over the coaxial cable system. At a surface site a nonpower passing device is used to strip the video signal from the cable at a normal surface tap. A TV monitor at the surface site is set to channel 5 and is used to view everything the TV camera transmits.

5.1.1.7 System Diagnostics

Several diagnostic subroutines, initiated from the system center, are available to troubleshoot the system and detect faulty hardware. In addition, all telephones are continuously polled for correct responses and the failure of any device to respond is reported along with an identification of the nonresponding device.

5.1.2 Hardware Description

The hardware for the communications and monitoring system includes the system center, telephone instruments, cable plant (distribution hardware), monitor/control equipments, radio interface hardware, and television equipment.

5.1.2.1 System Center

The system center consists of a control minicomputer (processor) with input/output device (teleprinter or TTY), distribution/information tone module (DITM or FDM controller), and bridging amplifier (figure 5-5). The monitor/control display was originally a separate unit from the system center (figure 5-6) but was later incorporated into the system center cabinet (figure 5-7).

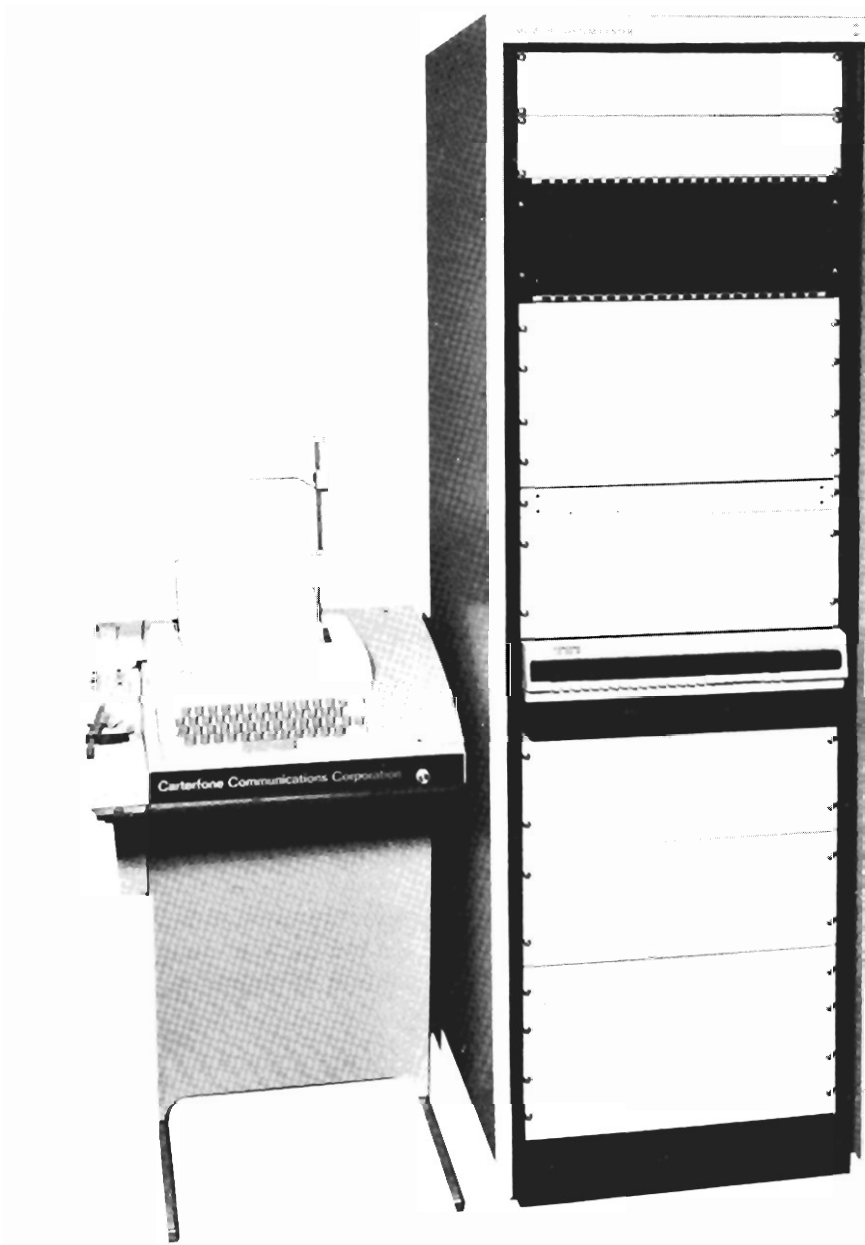

Figure 5-5. System Center With Processor, DITM, and Teleprinter.



Figure 5-6. Monitor/Control Display Matrix (Preliminary).

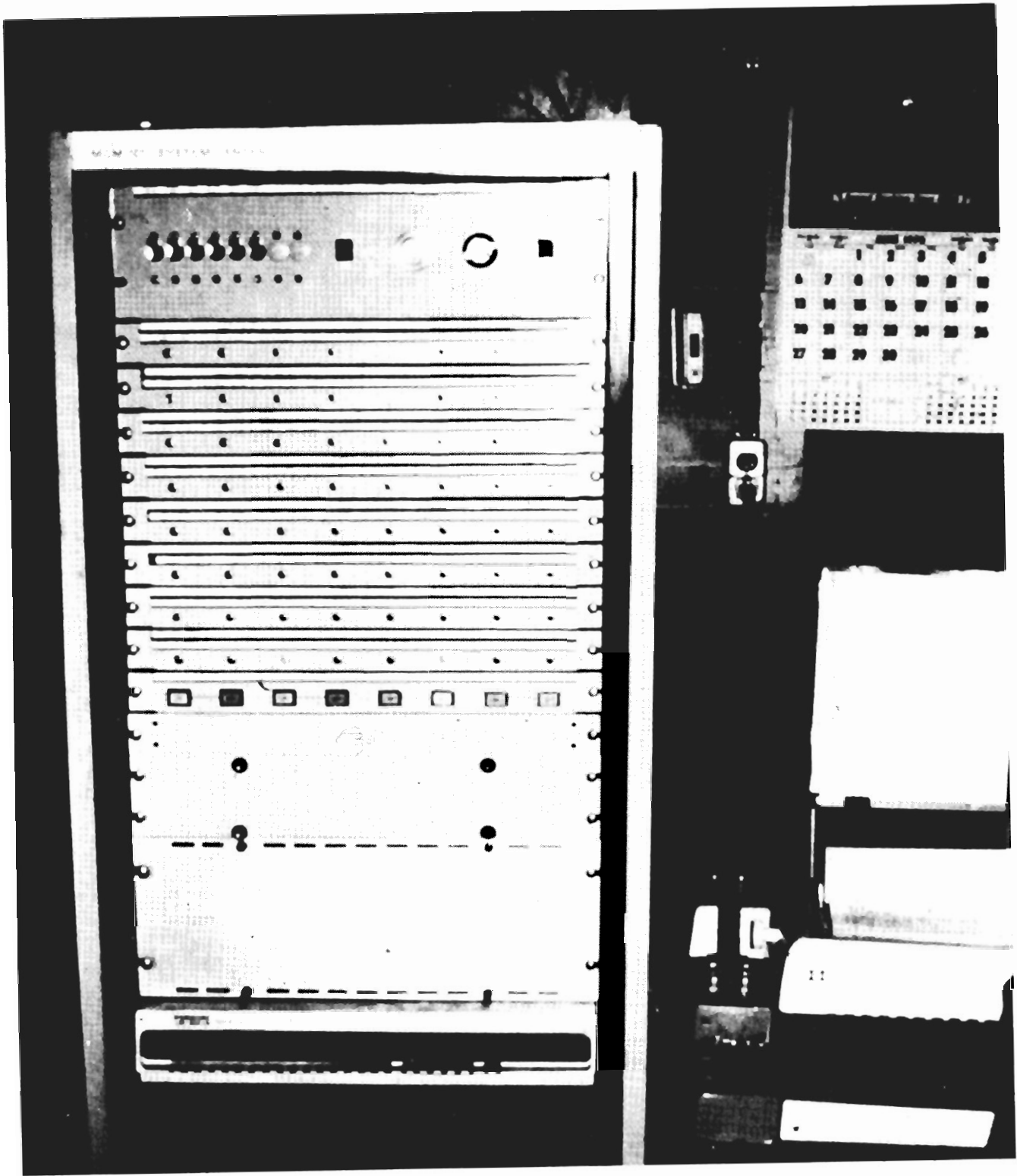

Figure 5-7. System Center With Monitor/Control Matrix (Final).

The DITM consists of an information tone/modem, up-converter, and rf matrix. All communications and monitoring within the system are routed through the rf matrix. The information tone/modem contains a tone generator and four fixed-frequency FDM transmitters. These FDM transmitters provide dial, ringback, busy, and invalid tone FDM channels. Tones are continuously transmitted on the four information tone FDM channels. When required, the telephone instruments are tuned to the appropriate information tone FDM channel. The up-converter is used to convert channel T-7 signals to channel 1 signals.

The processor provides all control and monitoring for the system as well as storing all pertinent data. The bridging amplifier amplifies and combines the in-bound channel T-7 and outbound channel 1 signals. The monitor/control display matrix provides the display for all monitored parameters and the initialization for all controls.

The system center is housed in a standard 19-inch rack cabinet and all internal components are powered by voltages derived from the 117-v ac input. The system center is intended for use in normal office environments.

5.1.2.2 Telephone Instruments

Two types of telephones are used in the communications and monitoring system: a standard desk mount surface unit and a ruggedized unit with additional features intended for use underground.

The surface telephone is similar in appearance to the standard single-line pushbutton telephone used by public telephone companies (figure 5-8). A 12-button keyset and a special function light are located on the front. The keyset is used to dial the number of other telephones or to perform special functions available on the system. The special function light is used to indicate that incoming calls have been forwarded to another telephone. The surface telephone consists functionally of a fixed-tuned AM transmitter and receiver for processing the commands and responses required by the system center and a signal-sideband (SSB) transmitter and receiver for processing the audio associated with the communication link. Surface telephones are powered with a nominal 28 v dc that is carried on the coaxial cable with the rf signal. The surface telephone is intended for surface office environments only.

The underground telephone has the same functional "phone" capabilities as the surface telephone; however, because the underground telephone does not have a special function light, users cannot initiate the call forward feature. The underground telephone features a ruggedized, dripproof enclosure and is equipped with an emergency/paging transmitter, monitor/control interface circuitry, and a rechargeable battery pack (figure 5-9). The telephone enclosure was redesigned as depicted in figure 5-10 into a smaller, lighter weight unit. Both underground telephone case designs are used at Robena. The underground telephone is also capable of displaying an indication of various levels of CH₄, CO, or air velocity; depending on which remote monitor is attached. Control information for remote control units can also be routed through underground telephones that are so equipped.

With the emergency/paging transmitter, the underground telephone is capable of transmitting paging information to selected individuals who are carrying pocket pagers. This transmitter can also be used to transmit emergency signals (coded) to the surface in the event of a "trapped miner" situation.

When the primary 28 v dc underground power on the coaxial cable is removed, the underground telephone reverts to internal battery power with full capability. Upon return of the primary power, the telephone returns to cable power and recharges the battery pack. Going



Figure 5-8. Surface Telephone.

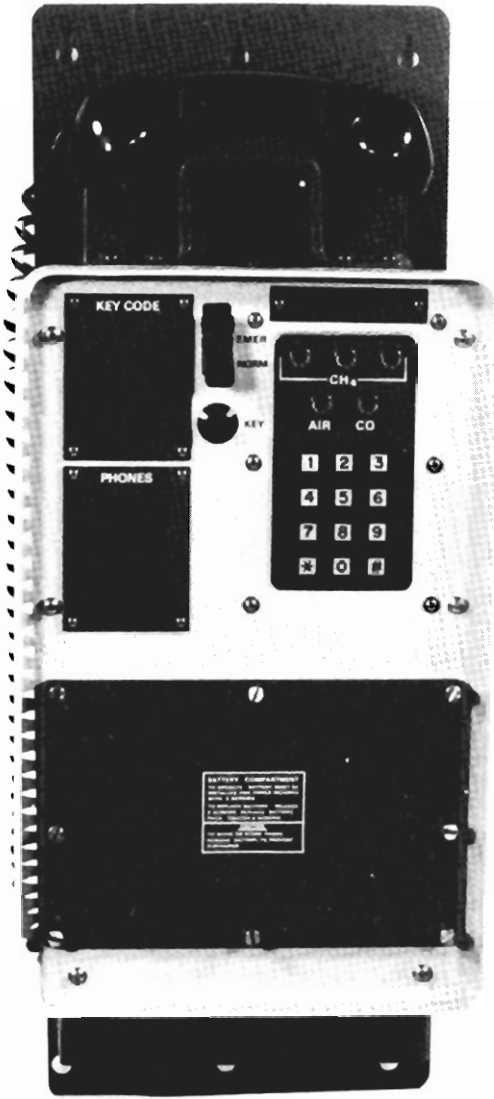

Figure 5-9. Initial Design or Demo Version Underground Phone.



Figure 5-10. Underground Telephone With Redesigned Enclosure.

to battery power and the return to primary power as well as emergency use of the emergency/paging transmitter is reported to the system center for teleprinter or matrix display. The underground telephone is intended for use in underground mining or other environmentally harsh industrial applications.

5.1.2.3 Monitor/Control Equipment

Two types of devices are used to provide monitor and control functions: environmental monitors for sensing methane, air velocity, and carbon monoxide (presence of fire), and monitor/control units for monitoring and controlling various devices. Both monitor types are attached to and receive power from underground telephones. The underground telephones also serve

as relay points, passing the monitor or control data to the system center. All units are designed for stationary continuous duty and are housed in ruggedized, dripproof, dust-proof enclosures.

Environmental monitors consist of a three-function (CH_4 , CO, and air velocity) unit (figure 5-11); and a presence of fire unit (figure 5-12). Adjustable thresholds provide the output of each sensed parameter. The underground telephones to which the monitors are attached display the status of these monitored parameters and also send the information via the coaxial cable to the system center for display. These monitors require frequent calibration using known concentrations of gases or against a calibrated air velocity meter.

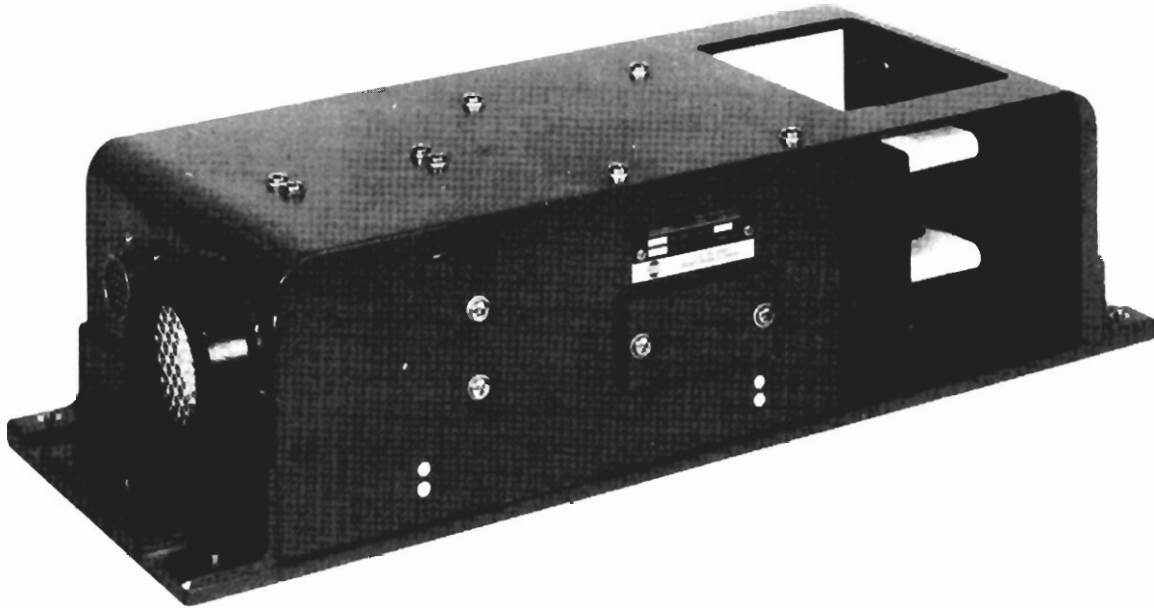

Figure 5-11. Three-Function Environmental Monitor.

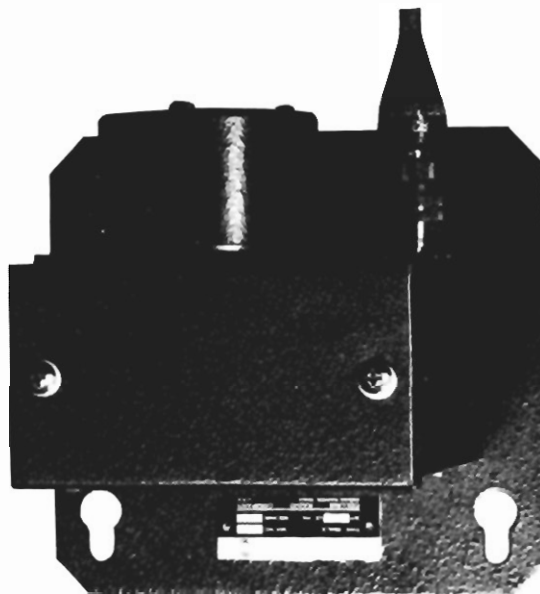

Figure 5-12. Fire Monitor.

The second type of monitor (figure 5-13) provides for the sensing of three relay contact closures for the purpose of monitoring the status of equipments (fans, pumps, circuit breakers, etc). In addition, a version of this device provides on-off control of three functions via 10-ampere relay contacts.

Monitor and control information is sent over the coaxial cable via the telephone to which the device is attached. Local display at the telephone is not provided.

5.1.2.4 Emergency/Paging Equipments

The paging system consists of emergency/paging transmitters, pocket pagers, escapeway receivers, and 400-foot loop antennas. The emergency/paging transmitter is a through-the-earth audio transmitter used as a page transmitter under normal conditions. It is an internal assembly in all underground telephones and is part of the paging system. The transmitter makes use of two discrete oscillators, one each for paging and emergency transmissions. The page information to be transmitted is received via the data link between the transmitter and the underground telephone in which it is installed. The emergency and paging functions share an external 400-foot loop antenna. The emergency transmitter portion is manually operated by turning the on/off switch to the up (ON) position, thus activating the emergency frequency at a preselected duty cycle. This duty cycle can be overridden by pushing the key switch.



Figure 5-13. Monitor/Control Unit.

The pocket pager (figure 5-14) is a battery-powered, portable receiver used to alert its user of specific page transmissions from emergency/paging transmitters. The receiver responds to a particular address and to a general "all call" address. Reception of a valid page is indicated by a one-second 400-Hz "buzz" and the lighting of a red LED. The LED remains on until a reset button on the pager is pushed. The rechargeable battery is designed to provide continuous operation throughout a 10-hour shift. The page number is assigned by internal strapping in the pager.

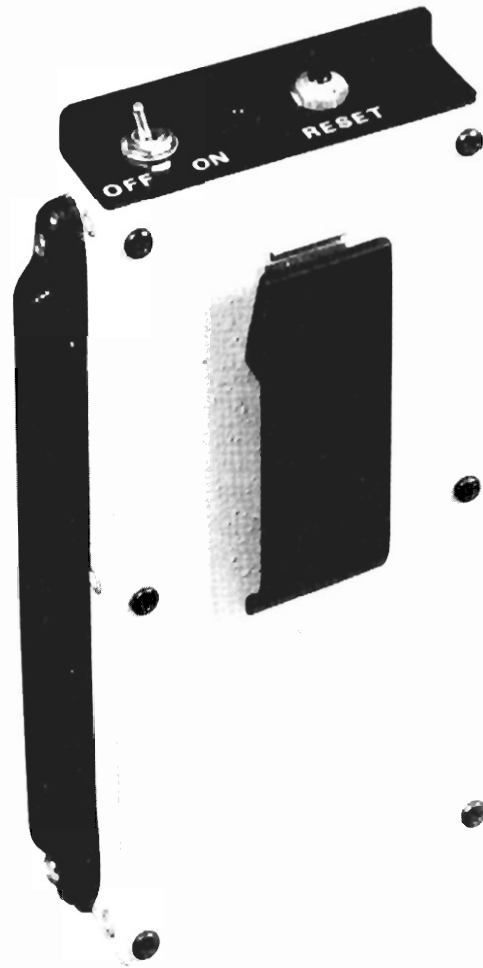

Figure 5-14. Pocket Pager (Call Alert Receiver).

The escapeway receiver (figure 5-15) is a direct through-the-earth audio receiver to be used as a mine escapeway receiver in emergency conditions. The receiver functions as a down-link communication path to augment the up-link communication path provided by the emergency code transmitter in the emergency/paging transmitter. The escapeway receiver is attached to, and receives primary power and antenna signal from underground telephones. Controls and indicators on the escapeway receiver include an ON-OFF switch (spring loaded to return to the OFF position), volume control, primary power indicator, and speaker. The unit is packaged for the underground environment.

5.1.2.5 Radio Interface Equipment

The radio interface (figure 5-16) provides interface between the communication and monitoring system and a uhf transceiver communication system. The radio interface consists of an antenna, repeater, and interface circuitry and can be attached to the cable distribution network at any tap. The interface is a completely self-contained unit housed in a permissible enclosure and powered from the distribution coax. Only two cable entries are required for system operation, one connection to the distribution coax and another to a short transmission line terminated in a uhf antenna. A battery backup provides for over eight hours of power-down operation.

5.1.2.6 Cable Distribution Hardware

The communications and monitoring system uses cable television equipment to provide both rf signals and dc power to telephones and monitors. These equipments consist of line amplifiers with battery backup, taps (underground and surface), splitters, power inserters, and cable splices.

The surface cable plant uses 0.412-inch coaxial cable and standard CATV amplifiers. The 5-30 MHz return and 48-270 MHz outbound bandwidths allow three channels of closed-loop or 11 channels of one-way television transmission. Surface amplifiers are powered by 110 or 220 volts ac. Surface cable taps permit the attachment of up to four individual telephones (figure 5-17). The taps are used to "strip" dc off of the main cable for powering telephones and to provide an rf path between the main cable and the telephones.

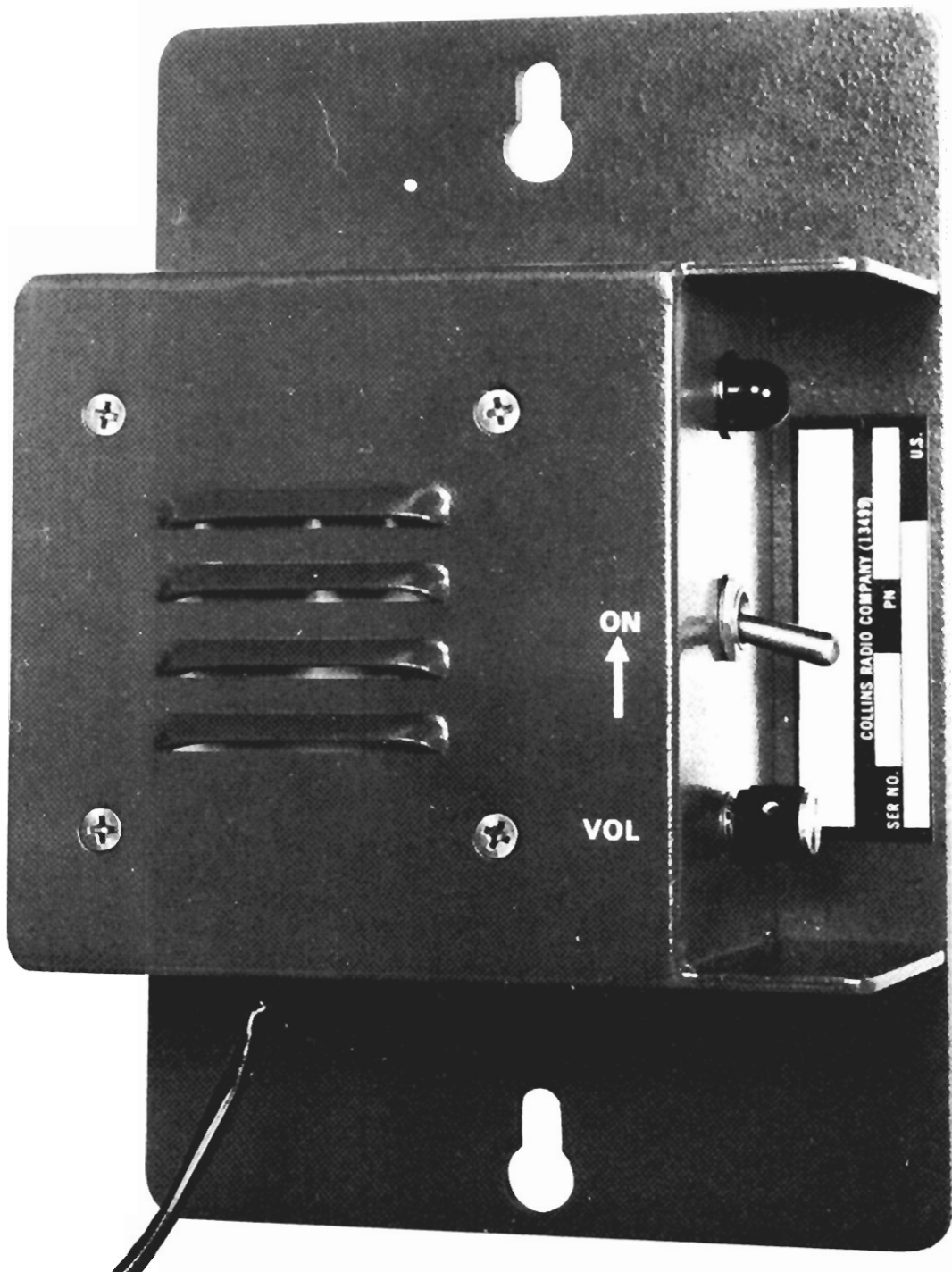

Figure 5-15. Escapeway Receiver.



Figure 5-16. Radio Interface.

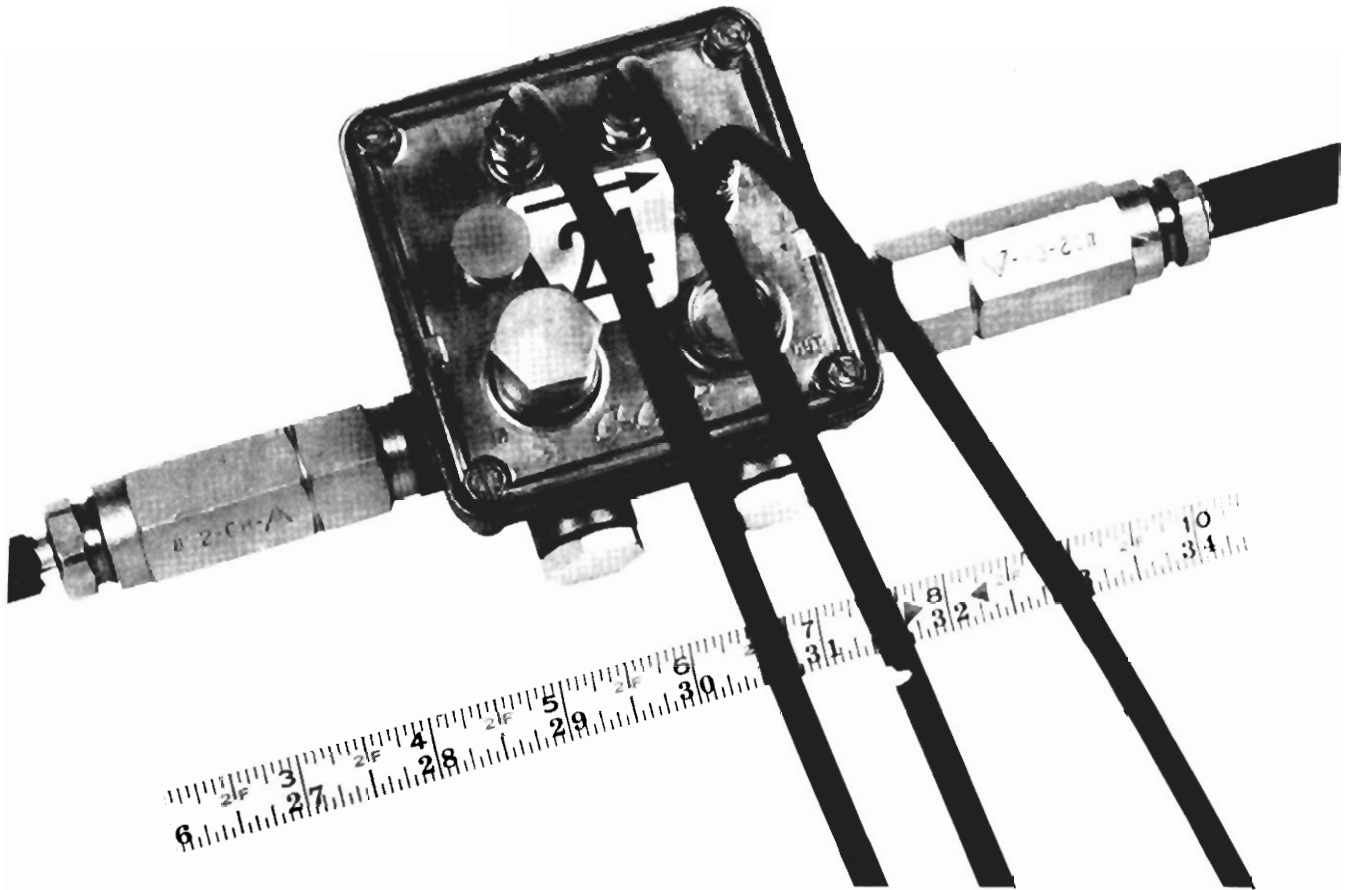

Figure 5-17. Four-Port Surface Tap.

The underground cable plant emphasizes durability. Cable taps (figure 5-18) are painted, contain fuse protection for the tap drops and incorporate type N connectors for strong, reliable connections. 7/8-inch coaxial cable is used for strength and to reduce dc losses. 48-volt dc power, inserted onto the cable using power inserters (figure 5-19), allows power supplies to be spaced long distances apart and still maintain adequate voltage for powering telephones and recharging batteries. Like the telephones, the amplifiers (figure 5-20) are equipped with battery packs (figure 5-21), providing 30 hours of standby power in the event of underground power failure or turn off. The line amplifiers have these features for long life:

- a. Corrosion resistant paint
- b. Transient protection modules
- c. Plug-in amplifier and power supply modules
- d. Protective fusing of line power; amplifier, and power supply modules

To further increase reliability in case of a mine disaster, which may sever even the large 7/8-inch coaxial cable, the system features loop-back function. A system with loop-back can feed signals from both directions in a major loop throughout the mine complex. Normally the signals flow in one direction only. If the cable is cut, the line amplifiers recognize the signal loss and reverse the signal direction. Special bidirectional taps are used to maintain the correct signal levels when the signal's path is reversed.

Figure 5-18. Underground Cable Tap.

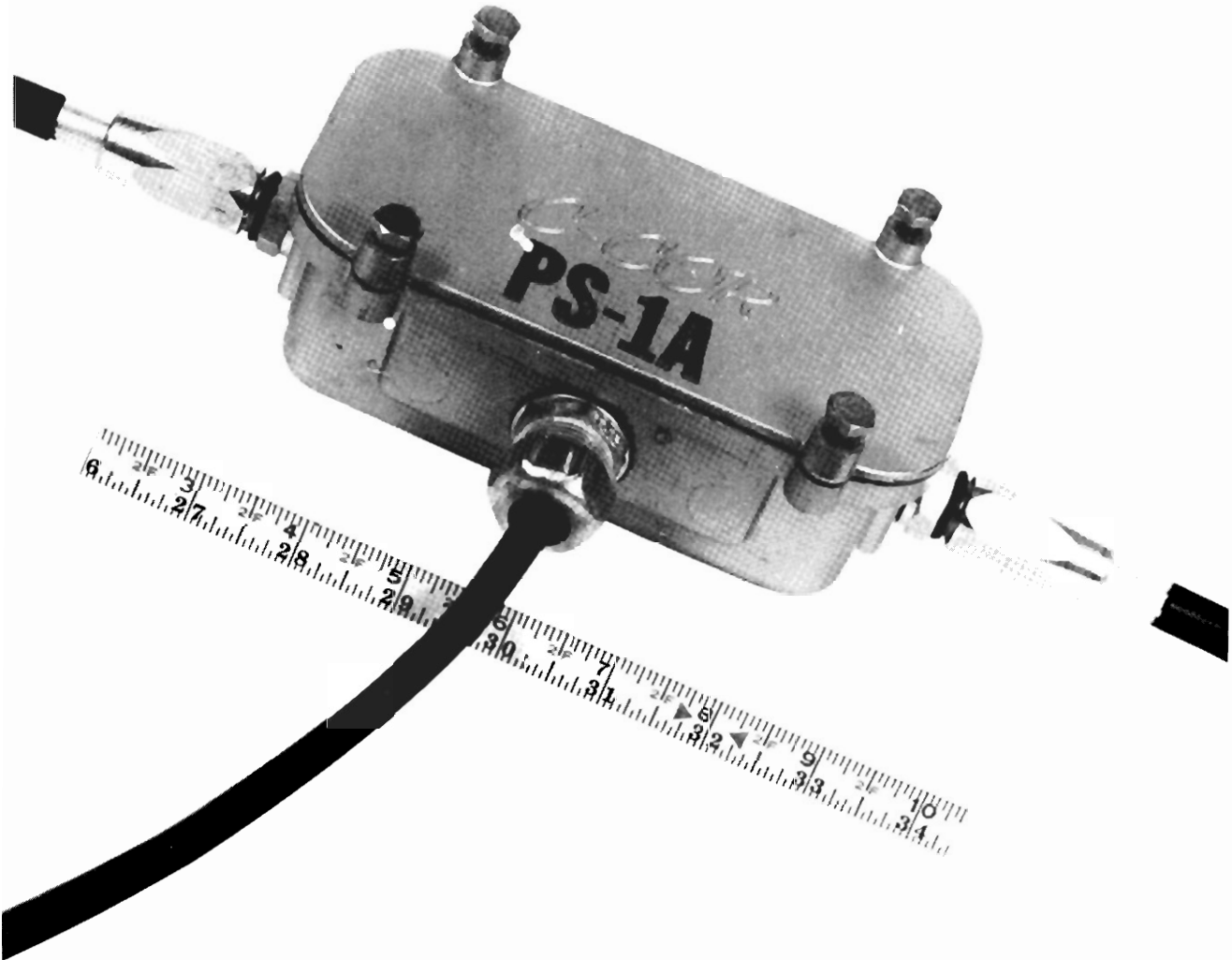
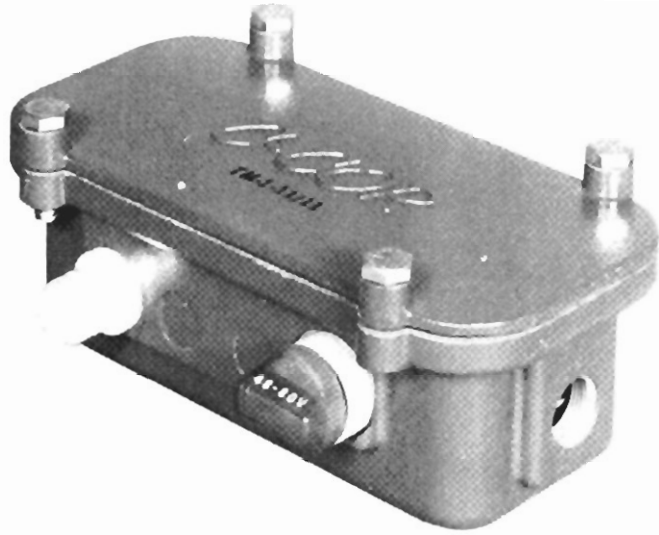

Figure 5-19. Power Inserter.

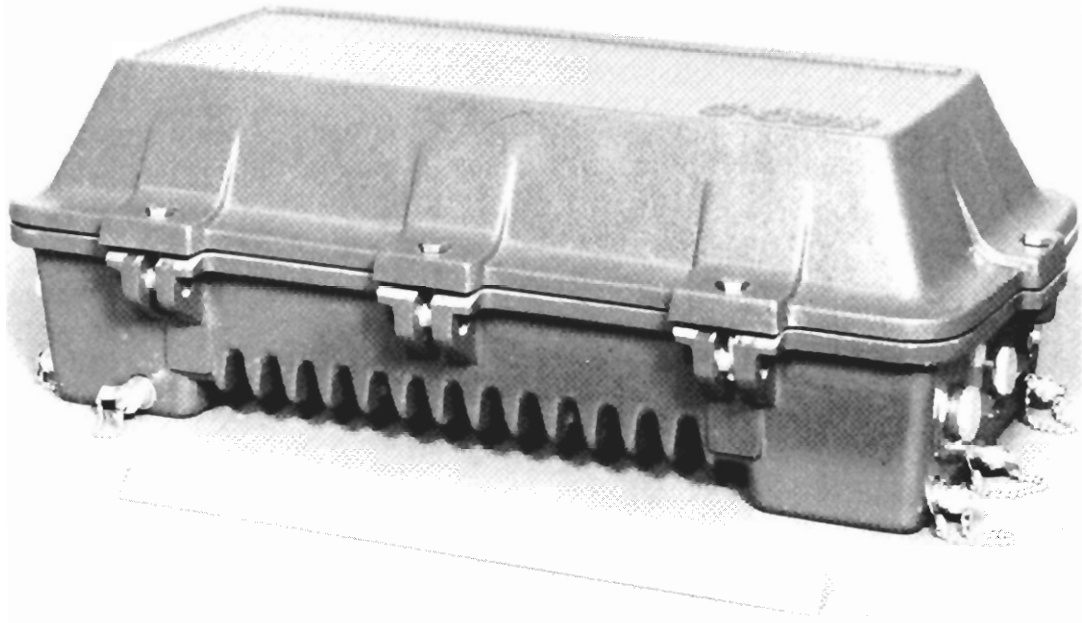

Figure 5-20. Underground Line Amplifier.

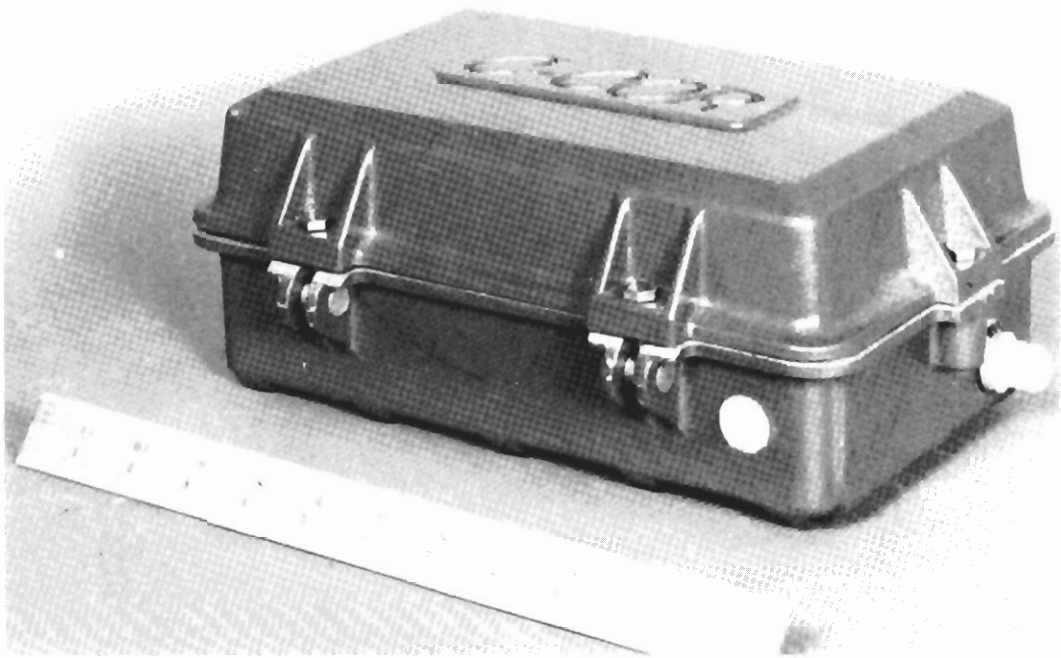

Figure 5-21. Line Amplifier Battery Pack.

5.1.2.7 Test Equipment

The telephone test set (figure 5-22) is a portable test set used for testing underground telephones. The test set measures RF IN (level of the rf signal received at the telephone), RF OUT (level of the rf signal transmitted by the telephone to the system center), BTRY (charge level of the backup battery contained in the telephone), PWR IN (dc voltage level being received by the telephone from the coaxial cable), and AUDIO OUT (level of audio signal output to the telephone handset). The meter on the test set indicates the level of the parameter being tested.

The test set is designed for portable continuous duty and is housed in a ruggedized dripproof, dustproof case. The unit requires 24- to 48-v dc operating power (supplied by the underground telephone being tested).



Figure 5-22. Telephone Test Set.

5.1.3 Installation

Prior to any installation efforts, site surveys were performed at the mine and interviews were conducted with supervisory personnel to review and verify all equipment locations. Since the installation was limited to a preselected equipment list (table 5-1), it was necessary to make judicious location choices to ensure optimum usage of all equipments.

If the entire Robena Mine complex would have been implemented, much greater quantities of telephone and monitor/control equipment would have been required. The site surveys and personnel interviews revealed that it was not necessary to implement the entire complex, as most of the mines were in retreat stages and soon would be mined out. Only one area of the mine, Willow Tree, was in active advance stages with prospects for years of future mining. In view of this fact, it was decided to install the bulk of the available components in this advancing area. In this manner, the longest demonstration period possible would be obtained. Since the men who mine in the Willow Tree area enter through the Colvin portal, and because most maintenance and production is directed from offices located on the surface at this portal, it was decided to locate the system center and a major portion of the surface telephones at this site.

All coal exits the mine at the Slope portal where it is cleaned, sized, and shipped. This site was, therefore, also selected for surface and underground telephones. In a like manner, the Garards Fort area was selected for equipment installation because it is a secondary location of coal production and a major portal for directing maintenance and production activities.

Equipment supplied under provisions of USBM Contract SO346089.

Table 5-1. Equipment List.

ITEM	DESCRIPTION	QUANTITY
1	System center	1
2	Demo version underground telephone	6
3	Underground telephone	42
4	Surface telephone	24
5	Escapeway receiver	6
6	Pocket pager	24
7	Three-function environmental monitor	6
8	Fire monitor (haulage)	30
9	Three-contact monitor (fan)	1
10	Three-contact monitor/control (pump)	1
11	Telephone test set	5
12	Power supply (28/48 v dc)	4
13	Bridging amplifier	1
14	Line amplifier (nonlooping)	13
15	Line amplifier (looping)	12
16	Amplifier battery pack	25
17	Underground tap	52
18	Surface tap	15
19	Power inserter	8

Table 5-1. Equipment List (Cont).

ITEM	DESCRIPTION	QUANTITY
20	Splitter	5
21	Emergency/paging transmitter antenna	14,500 ft
22	7/8-inch cable splice	36
23	0.412-inch cable splice	24
24	Misc connectors	1 lot

In summary, the major emphasis for underground telephones would be the Willow Tree area with Colvin and Slope being the primary surface locations. Secondary locations would be Garards Fort both surface and underground. All other areas did not require new or improved communication and monitoring.

The installation of the communications and monitoring system took place as the following three-phase program:

- a. Demonstration system installation (July 1974 - March 1975)
- b. Final system installation (March 1975 - May 1976)
- c. Add-on equipment installation (June 1976 - September 1976)

The individual phases will be discussed in detail in the following paragraphs.

5.1.3.1 Demonstration System Installation

Because of the large size of the proposed communications and monitoring system and because not all system components were immediately available, it was decided to first install a demonstration system. This demonstration system would be composed of the system center and a token lot of cable hardware, telephone instruments, three-function environmental monitors, and display hardware. Other system features would not be demonstrated at this time but would instead be incorporated into the final system configuration. The reasons for the demonstration installation were threefold: one, to allow the mine personnel time to adapt to system operation, installation and maintenance prior to final system installation; two, to allow time to establish contact with and gain approval from state inspectors; and three, to provide a base for determining system reliability and possible system modifications prior to the final installation.

The demonstration system was first assembled and tested at the Rockwell-Collins Cedar Rapids, Iowa, lab facilities. Figure 5-23 shows a block diagram of this system as tested in the lab. Tests performed on the system included verification and debugging of the system operational software, operation of underground and surface telephone features, test of line amplifier operation and setup, and demonstration of environmental monitoring with local and remote displays. When the demonstration system operated to the satisfaction of USBM and Rockwell-Collins observers, it was disassembled and shipped to the Robena Mine complex.

Meanwhile, during the lab testing of the demonstration system, effort was underway at the mine to install the coaxial cable. Because of cost and availability considerations, it was decided to use 7/8-inch cable for the main lines and 0.412-inch for branch lines. This type of cable was readily available through the CATV industry and because of the large quantities

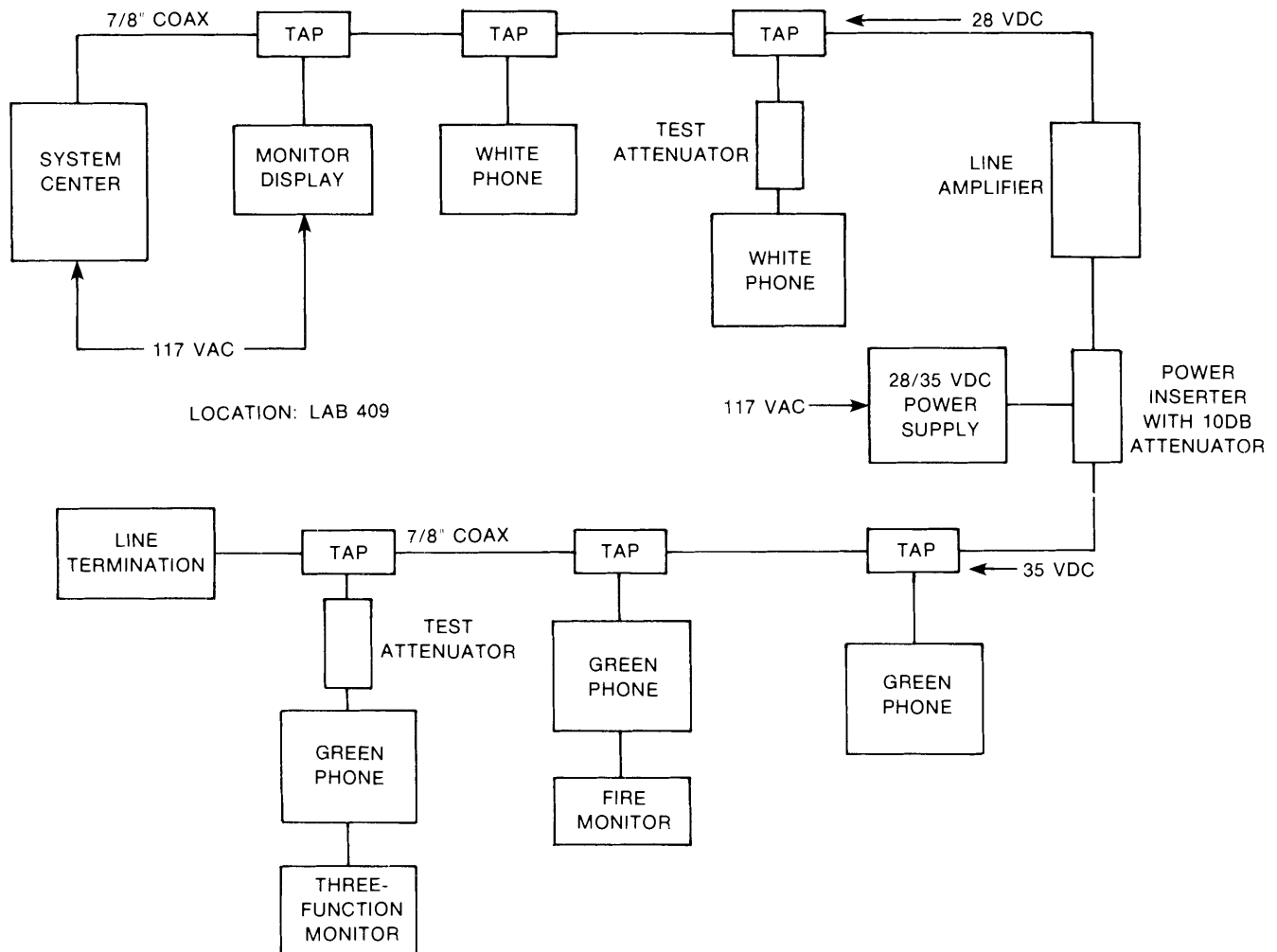

Figure 5-23. Communications and Monitoring System Lab Test Setup.

used, relatively inexpensive. The 7/8-inch cable came on 4-foot diameter reels each containing 2,500 feet of cable. Forklifts and flatcars were used to get the reels to the desired in-mine sites.

Prior to cable deployment, J-hooks were installed in the mine on existing structures to support the cable about every 15 ft. The reels were put on flatcars and spooled out via a special reel holder. Installation went rather quickly with over 6 miles of 7/8-inch cable deployed in one shift by two 6-man crews.

After cable deployment, the wiremen were given a short course in proper splicing techniques. The splicing is done by using a small tubing cutter to remove the jacket of the cable 4 inches from the end; then cutting away 3/4 inch of outer wall and dielectric all the way down to the center conductor. After cleaning with solvent, the cable is inserted into a special splice and tightened down with two wrenches using moderate torque (figure 5-24).

On the surface, 0.412-inch cable was used, supported by messenger wire between buildings.

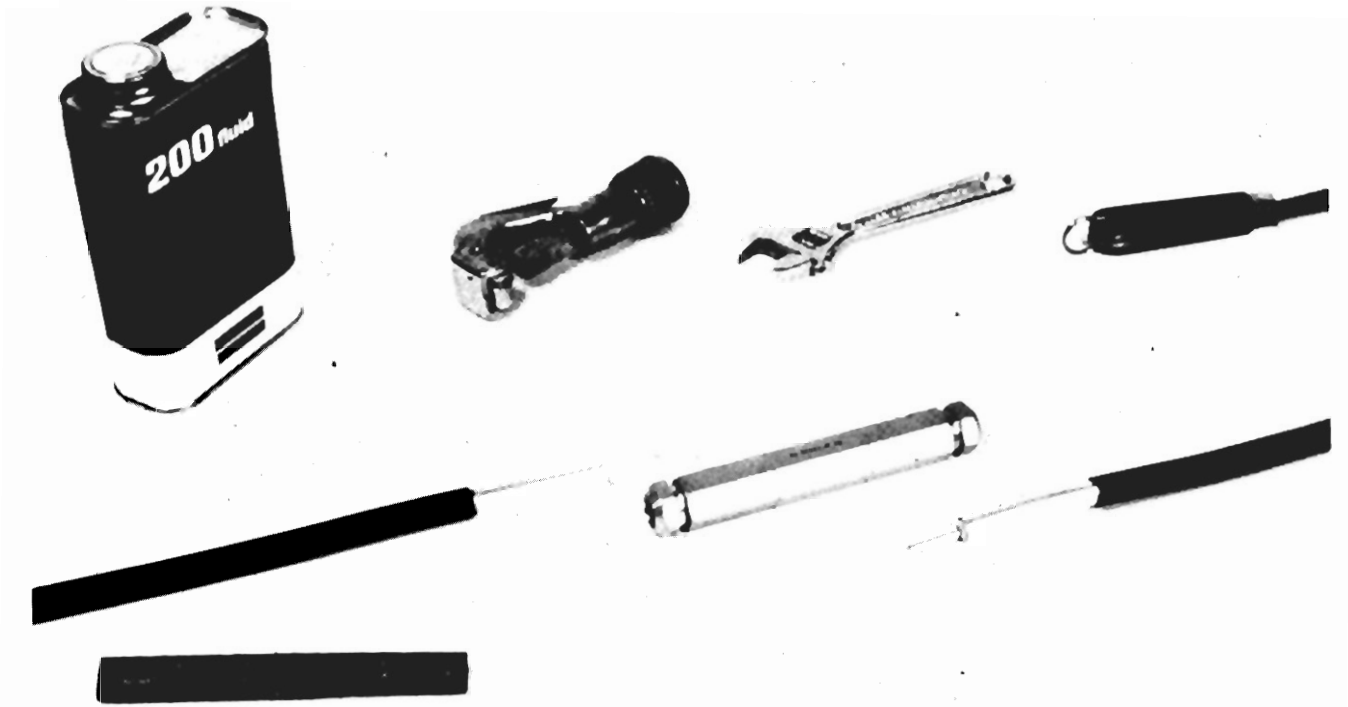

Figure 5-24. Cable Splice With Installation Equipment.

With the completion of the cable installation, a USBM/Rockwell-Collins team was on hand at the mine to aid the mine maintenance crew in installing the demonstration system. The system center, with the first version monitor display matrix, was located at the Colvin portal in the hoist house. This location was selected because a man is on duty 24 hours a day, 7 days a week and would be able to respond to monitor and control data. The hoist house is also fairly clean and would provide the computer in the system center with a suitable operating environment.

Final installation of the demonstration system was halted pending approval by Pennsylvania State inspectors. A meeting was then held at the mine with regard to this Pennsylvania State approval. USBM personnel, US Steel and Robena Mine management, Rockwell-Collins personnel, and state inspectors were in attendance. Approval was granted for one telephone underground for one week but was later amended to include all proposed equipments provided the following constraints were met:

- a. All telephones to be located in fresh air only.
- b. Cables entering the mine to be equipped with lightning arresters grounding the shield of each cable.
- c. All power on underground cables to be interlocked to the mine power so that it would be removed when underground power was off.
- d. All monitoring units not in fresh air to be submitted to the state for BFE approval numbers.

All of the conditions were met, and all monitoring and control units were placed in fresh air passages in the Robena System, thereby not requiring the BFE approval numbers. Surface

and underground locations were selected for the demonstration of system telephones and environmental monitors. These locations and the purpose for each are as follows (figure 5-25):

a. Surface Telephone Sites (Colvin)

1. Mine foreman's office - supervisory for production reports
2. Maintenance foreman's office - supervisory for equipment maintenance
3. Hoist room desk - system troubleshooting

b. Underground Telephone Sites

1. Colvin dispatcher - central operator
2. 29 chute - major track switching area often needing direct contact with dispatcher
3. 32 chute - underground mechanics shop frequently conversing with maintenance foreman
4. Willow Tree Flats section - longest transmission path, selected for test and demonstration

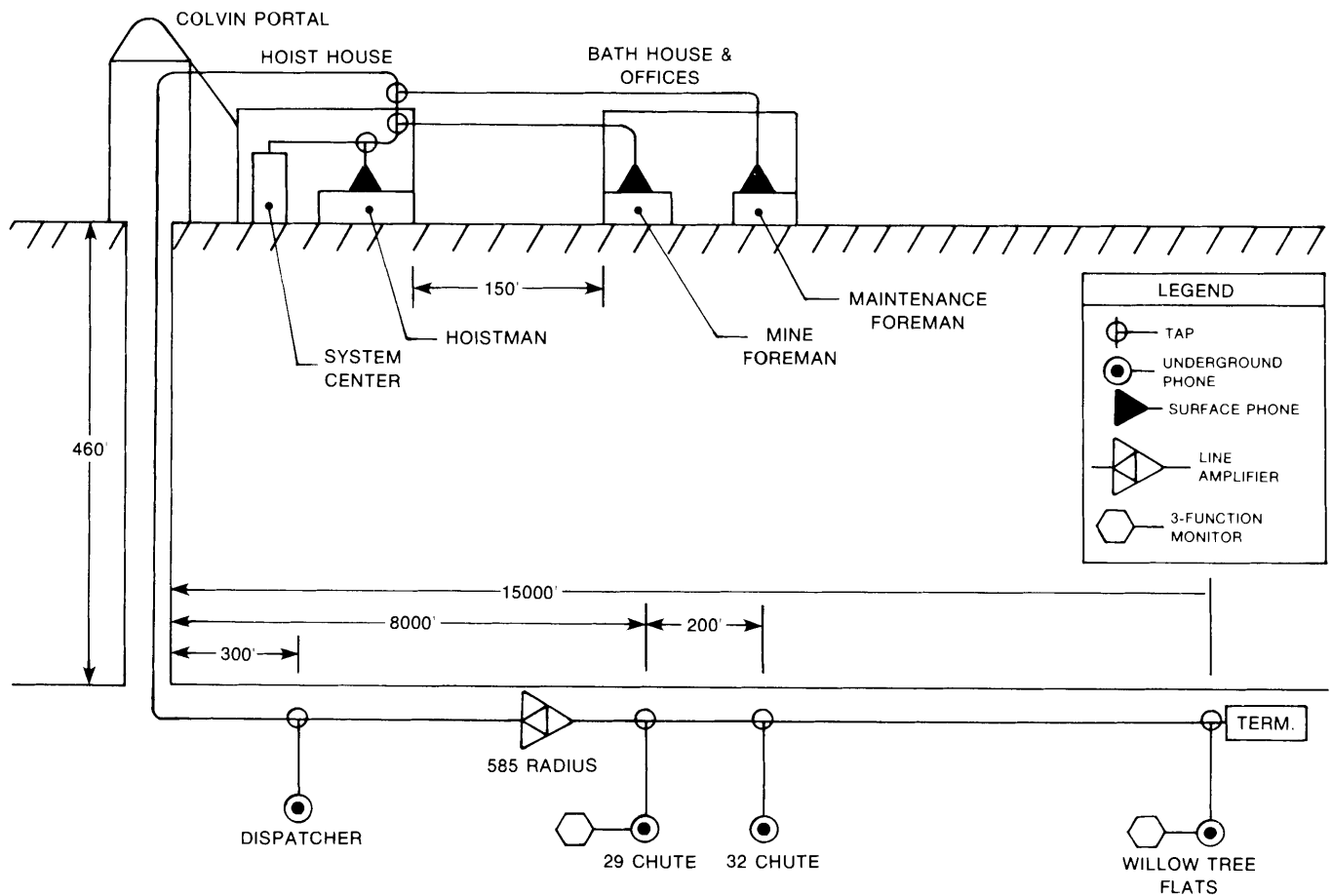

Figure 5-25. Robena Demonstration System.

c. Underground Environmental Monitor Sites

1. 29 chute - random location along a main haulage
2. Willow Tree Flats section - demonstrate section monitoring

The phones were placed where they would be used the most. The surface telephones were primarily for supervisory purposes and the underground telephones were for production or maintenance reporting. The system was used extensively by supervisory and maintenance personnel during the demonstration phase of the program, allowing the mine personnel time to gain familiarity with the operation, installation, and maintenance of the communication and monitoring equipments.

The experiences with the demonstration system led to the incorporation of several enhancements to the communications and monitoring system equipment. These included the following:

- a. Redesign the underground telephone (as discussed earlier) to reduce case size and weight and to improve maintainability and reproducibility. Several circuitry modifications were also incorporated to extend battery life and increase telephone operating features.
- b. Redesign the monitor display matrix from a separate unit to a series of panels incorporated into the system center rack. This redesign allowed for greater versatility and expandability.
- c. Provide greater monitor/control capability by designing monitor units capable of monitoring and controlling contact closures for remote operation of fans and pumps. Units of this type would be provided for the final installation.
- d. Increase computer memory for improved operating software with expanded diagnostic capability.

5.1.3.2 Final System Installation

As the system components were completed, they were forwarded to the Robena Mine, Colvin portal for installation. The demonstration system would remain intact, being replaced or added to as the final installation progressed. The results of the site surveys and personnel interviews are summarized with the list of equipment locations identified in table 5-2. As can be seen from the table, locations considered important for telephone placement included supervisory personnel, maintenance and production related functions, and dispatch and vehicle movement sites. Environmental monitor sites included working sections and key main haulage points. Power supplies were located so as to allow fairly equal load distribution. Figure 5-26 shows a diagram of equipment placement as implemented.

Table 5-2. Initial Communication and Monitoring Equipment Locations.

LOCATION	EQUIPMENT
Colvin Surface: Superintendent Mine Foreman General Maintenance Foreman #1 General Maintenance Foreman #2 Mine Clerk	Surface telephone Surface telephone Surface telephone Surface telephone Surface telephone

Table 5-2. Initial Communication and Monitoring Equipment Locations (Cont).

LOCATION	EQUIPMENT
Mine Rescue Room Supply House (front) Supply House (back) Shaft Top Outside Shop Foreman Car Shop Electrical Shop Hoist House Control Area Hoistman's Platform	Surface telephone Surface telephone Surface telephone Surface telephone Surface telephone/Klaxon Surface telephone Surface telephone Surface telephone/system center Surface telephone
Garards Fort Surface:	
Superintendent Mine Foreman Maintenance Foreman Mine Clerk Lamp Room	Surface telephone Surface telephone Surface telephone Surface telephone Power supply
Slope Preparation Plant Surface:	
Superintendent, Lab Screen House Hoist House Plant Foreman Maintenance Foreman	Power supply Power supply/Klaxon Surface telephone/Klaxon/power supply Surface telephone/Klaxon Surface telephone/Klaxon
Willow Tree Surface:	
Fan House	Surface telephone/power supply
Colvin Underground:	
Bottom Shanty Maintenance Shop Dispatcher Motorbarn 1 Back Action (switch area) 5 Chute (haulage) 1 Butt 29 Chute (switch area) 1 Butt 16 Room (section) Craty Borehole (power substation) 32 Shanty (mechanics shop) 47 X-Cut (pump location) 51 Chute (haulage) 69 X-Cut (switch area)	Underground telephone Underground telephone Underground telephone/environmental monitor Underground telephone/Klaxon Underground telephone/fire monitor Underground telephone Underground telephone Underground telephone/environmental monitor Underground telephone/fire monitor Underground telephone Underground telephone/fire monitor Underground telephone/fire monitor Underground telephone/fire monitor

Table 5-2. Initial Communication and Monitoring Equipment Locations (Cont).

LOCATION	EQUIPMENT
<p>Willow Tree Underground:</p> <p>Breaker Room (shaft bottom) 85 X-Cut (switch area) 103 Switch House (power substation) Rock Heading (section) 101 Brato (section) 8 X-Cut (haulage) 31 X-Cut (haulage) Right Side (section) 2 Panel (section) Flats (section)</p> <p>Garards Fort Underground:</p> <p>1 Side Track (haulage) 1 Left (haulage) 3 Right (haulage) Top No. 3 Side Track (haulage) Borehole (power substation) 5 Right (haulage) 4 Corner 3 Main (switch area) Machine Shop Dispatcher</p> <p>Slope Underground:</p> <p>Booster Pump A&B Pump Room Middle Chute of 5 (haulage) No. 5 Sidetrack (haulage) No. 1 Right (haulage) Grease Track No. 13 Chute (haulage) Dumps</p>	<p>Underground telephone/fan monitor Underground telephone/fire monitor Underground telephone/fire monitor Underground telephone/environmental monitor Underground telephone/environmental monitor Underground telephone/fire monitor Underground telephone/fire monitor Underground telephone/environmental monitor Underground telephone/environmental monitor Underground telephone</p> <p>Underground telephone/fire monitor Underground telephone/fire monitor Underground telephone/fire monitor Underground telephone/fire monitor Underground telephone/fire monitor Underground telephone Underground telephone Underground telephone</p> <p>Underground telephone/fire monitor Underground telephone/Klaxon/pump monitor Underground telephone/fire monitor Underground telephone/fire monitor Underground telephone/fire monitor Underground telephone/fire monitor Underground telephone/fire monitor Underground telephone</p>

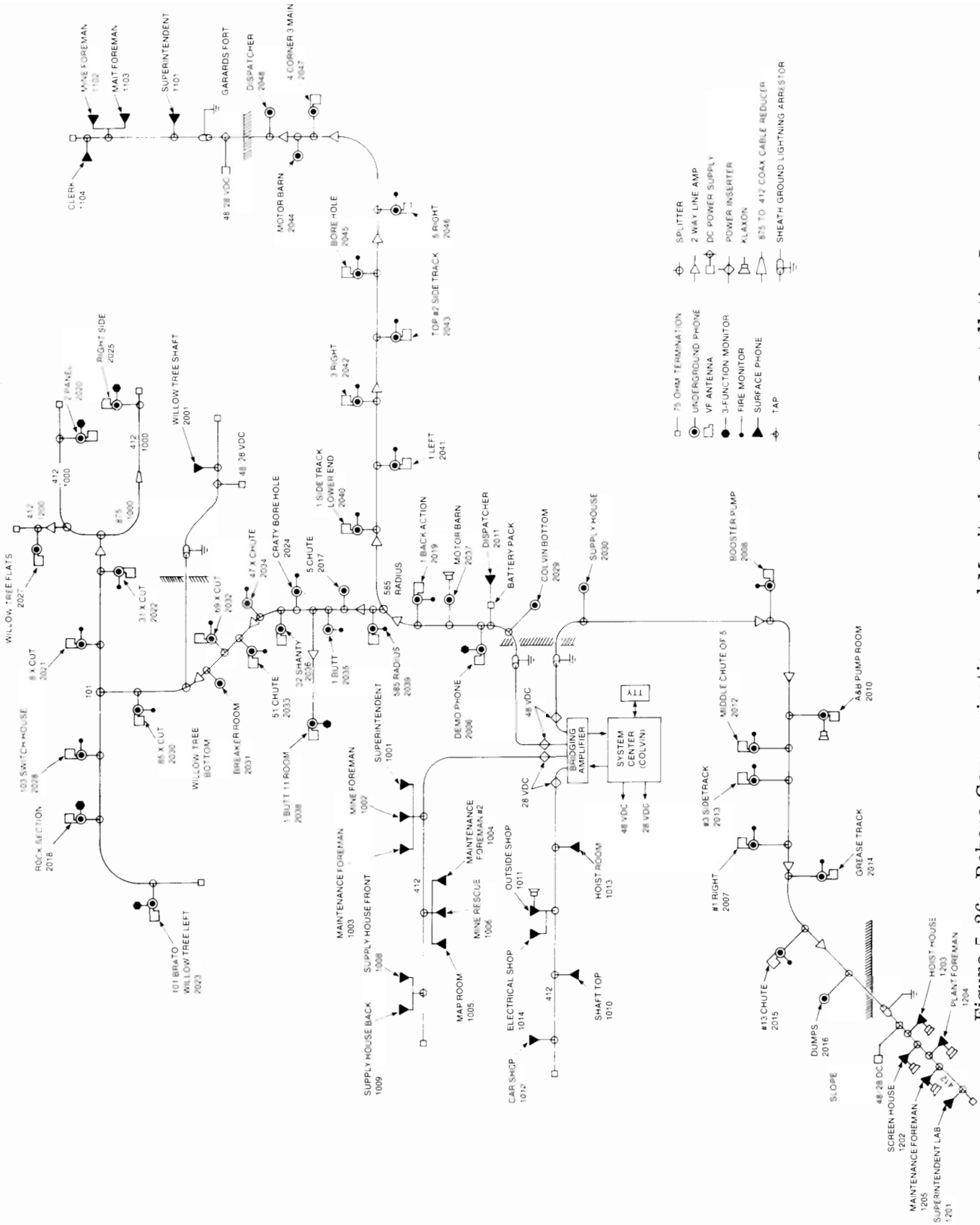

Figure 5-26. Robena Communications and Monitoring System Installation Less Loopback, Coupler Interface, and the TV Monitor System.

The main portion of the underground and surface distribution cables were installed by mine maintenance personnel prior to starting the final installation phase. Those cables not previously installed would be installed in conjunction with the other system components.

Final system installation began with a review of equipment locations and installation techniques with USBM and mine maintenance personnel. All underground equipments were marked as to location. The first area implemented was the Colvin surface portal. Effort included the stringing of individual telephone coaxial cable drop lines between the main cable and the telephone site, and the installation of telephone taps. Additional effort included the permanent location of system center and power supply equipments. Dedicated 117 v ac power circuits were provided for the system center and power supplies.

In a like manner, the surface installations at Garards Fort, Willow Tree, and Slope were implemented. Care was taken at all locations to ensure that reliable operation of the equipment would result. All telephones implemented at the Colvin portal as well as the Garards Fort and Willow Tree portals were surface units located on desks or other suitable platforms as shown in the example of figure 5-27. The surface telephones at Slope were for the most part



Figure 5-27. Surface Telephone Installation.

also placed on desk tops; however, due to the harsh environment at Slope, some of the telephones were enclosed in booths or other protected areas.

With the completion of the surface installations, effort turned to the underground areas. The underground equipments were installed in the following steps:

- a. Install basic telephone hardware and cable distribution equipment by areas and make operational before proceeding (that is, Colvin, Garards Fort, Willow Tree, and Slope).
- b. Install environmental monitoring equipment at proposed underground sites.
- c. Install emergency/paging transmitter antennas at designated locations.

At the completion of each step, the components were tested and all new hardware made operational, thereby eliminating the possibility of compound equipment type problems. Troubleshooting would be limited to one equipment type at a time.

All equipments were installed by USBM/Rockwell-Collins/mine maintenance crews with emphasis on an efficient reliable installation. Separate mine maintenance crews are used for Colvin/Willow Tree, Garards Fort, and Slope. This is because of maintenance personnel being assigned to specific areas of the mining complex. Some inconvenience was experienced as a result of this but no unsolvable problems were encountered. As the installation progressed, all maintenance crews became quite adept at the special handling techniques required for a coaxial cable system. Experience was also gained in telephone placement and hookup, speeding up later efforts.

The internal structure of a coal mine tends to be varied, offering a wide assortment of possible equipment mounting methods. Roof bolts, roof support timbering, and specialty structures make excellent devices for mounting communications and monitoring equipments.

At the Robena complex, every available mounting method was tried. Underground telephones were mounted on existing roof support posts (figure 5-28), or to specially made jack posts (figure 5-29). Environmental monitors, located along main haulages or at working sections, were mounted in a manner similar to the underground telephones. The three-function environmental monitors did, however, require mounting so that the air velocity sensor was open to the air movement in the haulageway (figure 5-30). The fire monitors required that the sensor protective caps be mounted facing down (figure 5-31). Cable distribution equipments were mounted from roof structures via spads and J-hooks. Later, as a result of various experiences, all cable components were provided with strain reliefs to improve reliability during disaster situations. Figure 5-32 shows an amplifier equipped with the strain relief.

Designated underground telephones were also fitted with emergency/paging transmitter antennas. These antennas consist of a 400-foot loop of 10-gage wire strung around an available coal pillar. The antennas attach to telephones with standard "banana" type plugs. With the antennas in place, mine personnel equipped with pocket pagers (figure 5-33) could be notified that they were needed. Paged miners can respond to pages by going to the nearest telephone and dialing the character # and his 3-digit page number. The system center will then automatically call the initiating telephone and connect the two parties.

Additionally, section telephones are provided with a reel of coaxial cable (either 0.412 or RG11), allowing the telephone to advance with the section. The scheme was eventually abandoned in favor of end-to-end connection of individual cable lengths (500 feet). The telephone could then be extended up to 500 feet or retreated up to 500 feet. It was not necessary to move the telephone the complete distance of the cable length as the cable can be coiled or doubled back on itself. Amplifier adjustments and variable tap values are used to ensure proper signal levels at the telephones.



Figure 5-28. Underground Telephone Mounted on Wooden Post.



Figure 5-29. Underground Telephone Mounted on Jackpost.



Figure 5-30. Three-Function Environmental Monitor Installation.

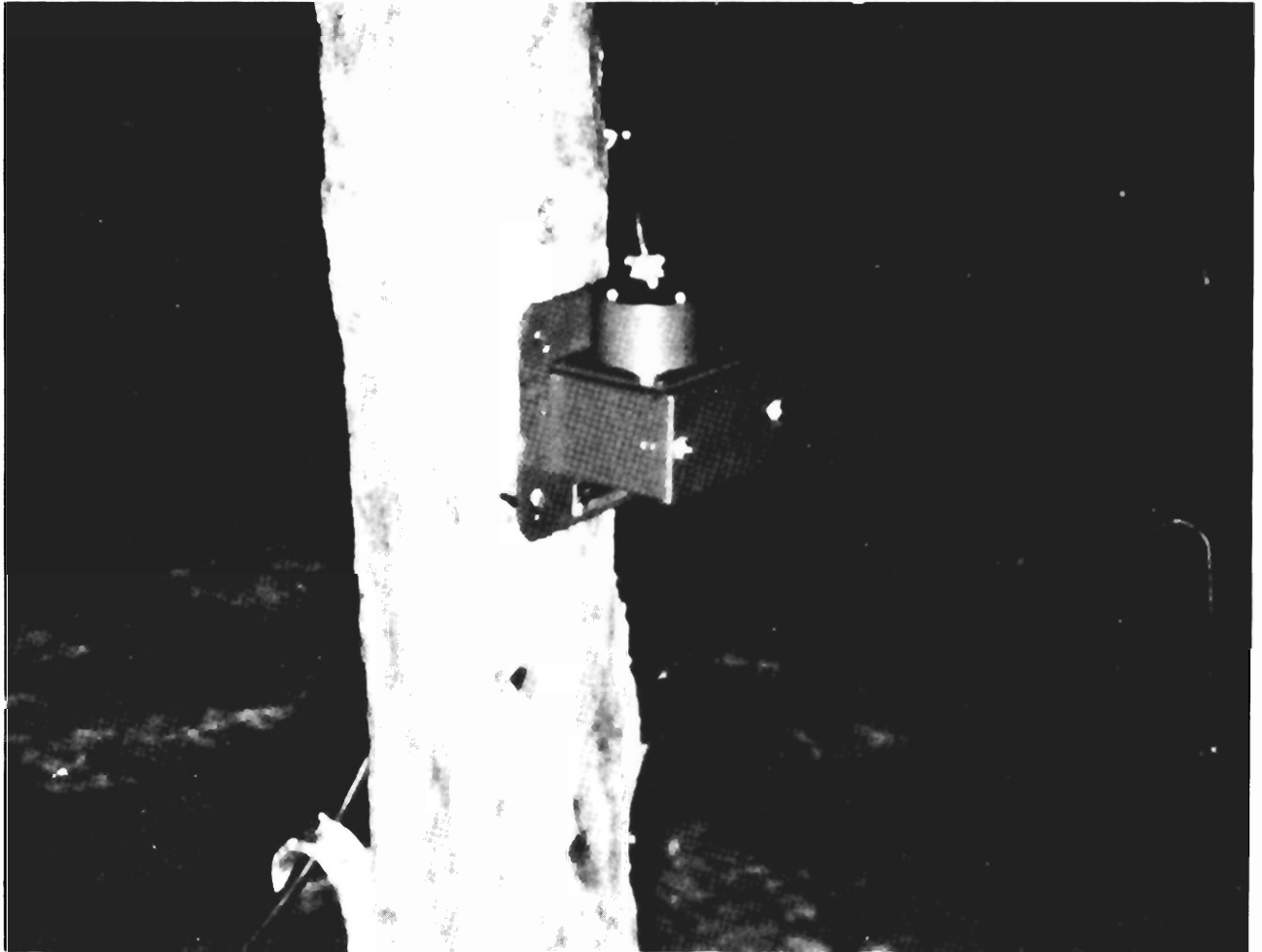

Figure 5-31. Fire Monitor Installation.

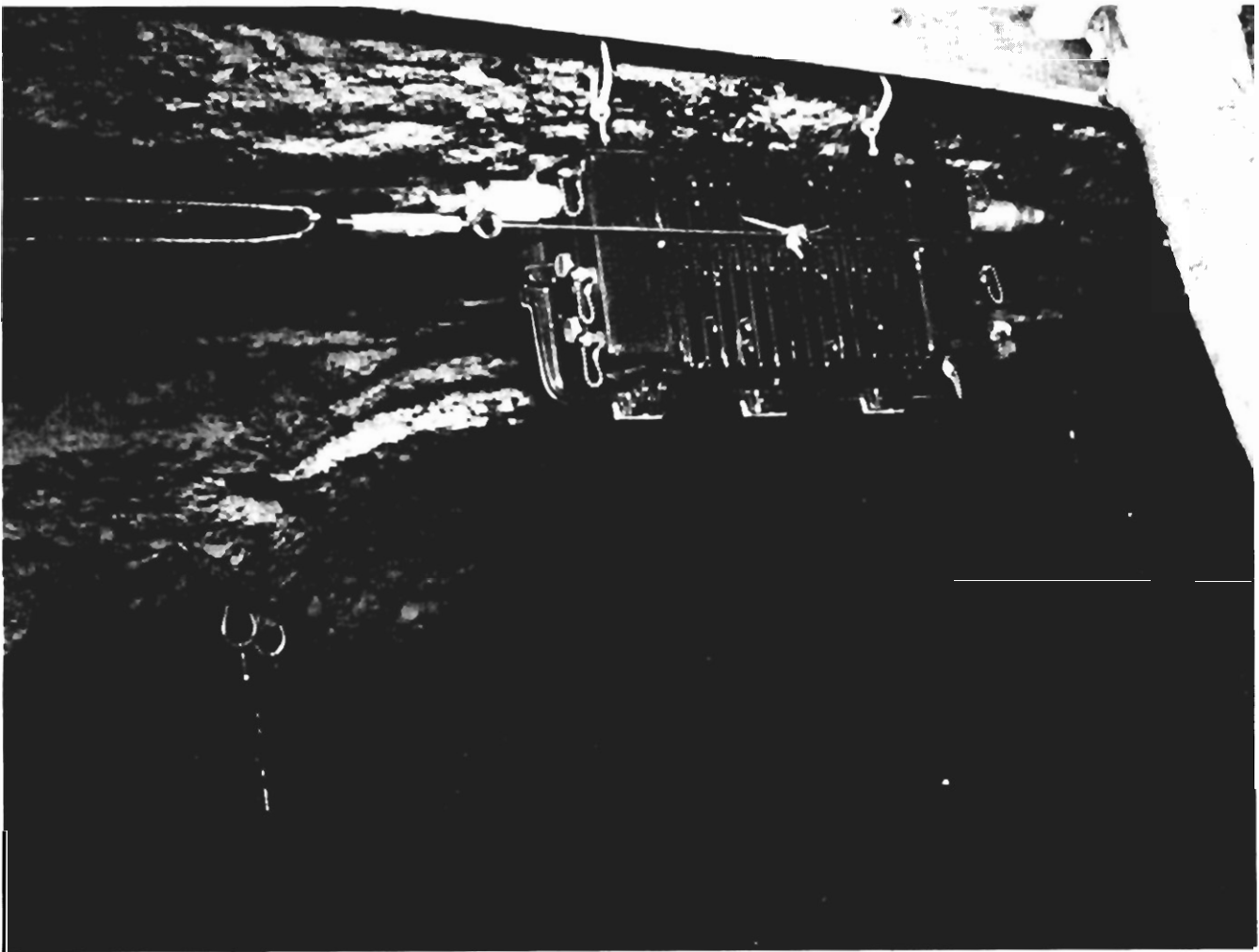

Figure 5-32. Underground Line Amplifier With Strain Relief.



Figure 5-33. Miner With Pocket Pager.

At the completion of this installation phase, it was seen that equipment improvements would be required. These improvements included the modification of several surface telephones (primarily at Slope) and a few underground telephones to operate 117-v ac Klaxons (loud sounders). Telephones equipped with the Klaxon modification are located in environments with high levels of background noise. The Klaxons are necessary to ensure that key individuals could be located. Another modification was the design and build of a battery box that allowed a surface telephone to be interfaced with the underground cable distribution network and provided battery backup for power-down situations. The Colvin dispatcher, located in an enclosed room underground (shanty), is equipped with a battery box of this type and a surface telephone is located on his desk top. This surface telephone provides more convenient access for the dispatcher than the underground telephone located outside the dispatcher shanty.

The automatic and manual diagnostics were extremely useful during the system installation. On several occasions the underground installation crew would incorrectly install a tap or improperly connect a monitor to a telephone. The teleprinter printout/diagnostic would immediately alert the surface of the problem so that corrective action could be taken. Telephones that were suspected of not being up to specifications were checked using the manual diagnostic, thereby saving many hours of installation time.

During the installation and at the completion of this phase, the system and its operation were accepted by mine management and maintenance personnel as a useful tool to improving production and safety. This phase concluded with the following complement of equipment having been installed: forty-one underground telephones; twenty-three surface telephones; six three-function environmental monitors; twenty-three fire monitors; the system center with monitor display matrix; sixty thousand feet of 7/8-inch coax cable; and three thousand feet of 0.412-inch coax cable with all cable distribution hardware necessary to support the aforementioned equipment. Equipment identified in table 5-1 but not installed during this phase would be used as spares or installed during subsequent phases.

5.1.3.3 Add-On Equipment Installation

The communication and monitoring system as implemented in the previous phase provides telephone communication and environmental monitoring of all the major areas of the mine complex. Locations include surface as well as underground sites. USBM, Rockwell-Collins, and mine personnel were generally satisfied with the operation of the various components. It was therefore agreed to implement the remaining features. These features are as follows:

- a. Cable loop-back
- b. TV monitor system
- c. Radio interface
- d. Equipment monitor and control

The above features were not implemented into the final system installation until, first, each item was individually tested and correct operation verified, and, second, the initial installation had proven itself as a viable system that provided reliable telephone communications and environmental monitoring. It was also determined that the add-on functions would be more readily accepted by the mine and easier to troubleshoot if the basic communications and monitoring system operated properly. The intent of the installation program was to gradually provide ever increasing capability in the system, allowing time for the mine personnel to accept and gain familiarity with operation and maintenance. Too much complexity too soon would not have been comprehensible by the mine maintenance personnel.

The first step of the add-on equipment installation was accomplished by the mine maintenance personnel, that of stringing the loop-back coax cable. This cable is the 0.412-inch version and was installed in the same fashion as the other underground coax cable, with J-hook hangers. The cable was located so that it provided a loop-back path for the Slope and Garards Fort areas (figure 5-34). With the cable properly installed, the USBM and Rockwell-Collins provided the assistance necessary to install and test the loop-back cable hardware. This assistance involved the hanging of the amplifiers and the balancing of amplifier gains so that when the loop reversed signal directions, no appreciable level change was noticed. This was necessary to ensure proper operation under the most severe conditions. The entire loop-back implementation, not counting cable installation, required only two days to complete. With the loop-back network installed, the overall reliability of the communications and monitoring system was greatly improved.

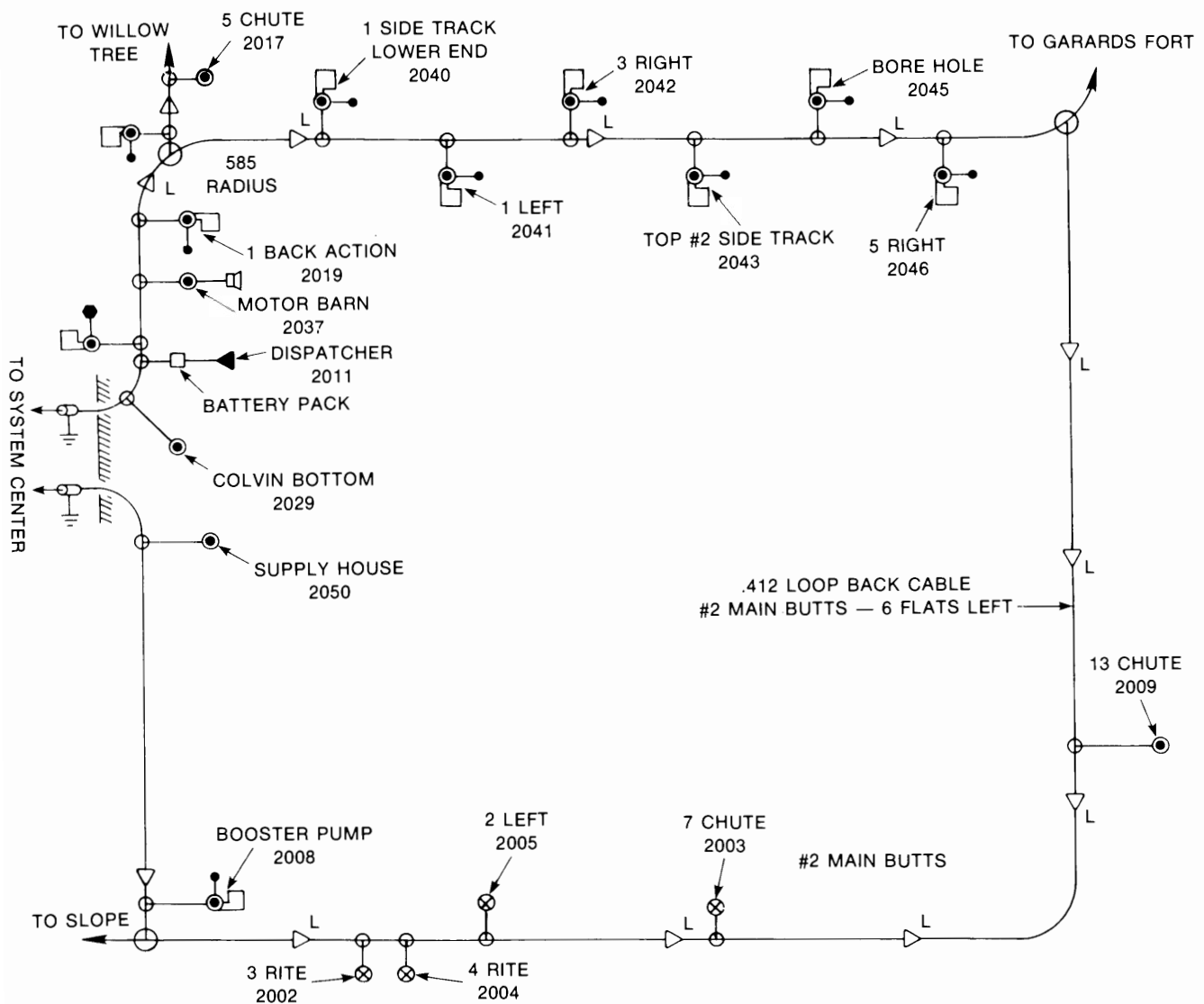

Figure 5-34. Loop-Back Cable Installation.

Several telephones are installed on the loop-back cable at designated locations. These locations include three retreating sections, a switching point, and a critical pumping station. Because all the newer version underground telephones had been implemented elsewhere, it was necessary to use the older or demo version units. These older units operate as well as the new units, they are just heavier and not as easily handled.

The second step of the add-on installation was the TV monitor system. The original intent had been to install the camera at Colvin bottom viewing the lowering of the cages with the monitor at the hoistmen's platform displaying this view; however, mine personnel felt that this would be a form of spying and make the men at the bottom self-conscious, thereby affecting safety. It was agreed to move the system, and the TV monitor system was implemented with the camera underground viewing passing loaded coal cars and the monitor on the surface to display these cars. This move could be made as the actual location of system components was not critical to the goal of the program, that is, demonstrating concept feasibility.

The TV camera and video modulator were located at the A and B pump room facing the haulage way. (The modulator converts the video into a channel T9 signal for transmission back to the system center.) Artificial lighting was also provided in the haulage way around the camera viewing area. A converter was located at the system center to convert the channel T9 signal into a channel 5 signal for retransmission back out onto the cable network. A standard television receiver, set to channel 5, was located in the mine superintendent's office for monitoring the passing loaded coal cars.

The underground equipments (camera and modulator) were housed in specially prepared enclosures to protect them from the harsh mine environment. Surface equipments (converter and TV monitor) did not require special packaging and were installed as received from the manufacturer. At the underground camera site and at the surface monitor site, dc power blocking devices were required to keep the dc power on the cable from damaging the TV system equipments. These blocking devices allowed the passing of the rf signals but did not allow passage of the dc voltage.

The third step of the add-on installation was the radio interface equipment. The radio interface equipment, as delivered for installation, was a complete operating system. All that was required to provide a wireless link to the communications and monitoring system was to attach the interface to the cable network at a convenient location. Equipments were pre-packaged to allow for usage underground; however, when an attempt was made to install the interface underground, state inspectors stopped the installation. The inspectors did not object to the specially developed interface hardware, but they felt that the portable transceivers should have tamperproof nonremovable battery packs.

Pending modification to the transceivers and approval to install the system underground, the coupler interface was "temporarily" installed at Colvin surface. Transceivers were allocated to various supply personnel who were normally difficult to locate. The radio interface system became a type of paging system, allowing underground maintenance personnel to more easily locate supply personnel and thus supplies.

The use of the radio interface by supply and maintenance personnel became such an integral part of the normal routine of locating and identifying supplies that in spite of receiving state approval, it was never installed underground. The original operational concept of the radio interface had been to provide a wireless link within a working section and to the surface. Unfortunately, in view of the temporary Colvin surface site becoming a permanent location, it was not possible to test this operational concept. The feasibility of a wireless link to the communications system was, however, successfully demonstrated.

The final implementation required to complete the communications and monitoring system was to install devices that would demonstrate the feasibility of remote monitoring and controlling via the coaxial cable. Two devices had been designed to fulfill this role, a unit that could monitor three contact closures and a unit that could control three contacts as well as monitor three.

The site surveys had revealed that the fans located at the top of all shafts needed additional monitoring and that the major pumps at the A and B pump room needed to be monitored and controlled. The Willow Tree fans provided fresh air to the largest number of personnel, and the A and B pumps removed all of the water (either from seepage or the mining process) from the mine. It was therefore decided to install the monitor only unit at the Willow Tree area to monitor the two fans at that location, and to install the monitor/control unit at the A and B pump room to monitor and control the operation of the two pumps located there. Each device required interface with an underground telephone that had been modified to disable the local display and to provide the control information.

The monitor unit (fan) was located at the Willow Tree bottom breaker room and provided with twisted wire pairs to the two fans located on the surface. The monitor/control unit (pump) was located in the A and B pump room. Both locations were equipped with specialty underground telephones. The fan monitor unit was attached to pressure switches, thereby providing on/off status of the two fans. The pump monitor/control unit was not attached to the pumps because of mine management's reluctance to rely on surface remote control of the pumps. To demonstrate the operation, however, the unit was integrated with the TV monitor system. The unit was used to monitor and control the on/off status of the camera.

The monitor/control unit was shown to work reliably controlling the TV camera, and permission was granted by mine management to implement the monitor/control features at a secondary pumping station. This station is the 13 chute, located in the cable loop-back region (refer to figure 5-34). The equipment was relocated to this new site, but at this writing it had not been completely implemented. The monitor/control unit is attached to the telephone and both units are operational; however, no attachments have been made to the pumps. Interface difficulties (the pumps are 600 v dc and the monitor/control unit is capable of monitoring and controlling 117 v ac maximum), compounded with the extremely remote location of the 13 chute have delayed the final hookup. Mine maintenance personnel are scheduled to complete the job and it is expected to be operational by the time this report is published. At any rate, the monitor unit and the monitor/control unit were both demonstrated to be operationally feasible functions. Additional development should correct any potential interface problems.

The completed installation includes all the equipment listed in table 5-1. The final installation covered 14 square miles using 60,000 feet of 7/8-inch cable, 30,000 feet of 0.412-inch cable, 15,000 feet of RG11 underground telephone drop cable, and 2,000 feet of RG59 surface telephone drop cable. All equipment, once properly debugged, operated as expected with only routine maintenance.

The installation was a joint effort between Robena, USBM, and Rockwell-Collins personnel. All parties cooperated to make the Robena communications and monitoring system a reliable demonstration of operational concepts.

5.1.4 Follow-On Modification, Maintenance, and Support

The Robena communication and monitoring system did not always operate on two TV channels, using one for signals from the system center to telephones and the other for signals from telephones to the system center. The initial system, including the demonstration phase, was

designed to operate only in the 7- to 11-MHz region (channel T7) of the radio spectrum. The coaxial cable, 7/8 inch for main trunks and 0.412 inch for branch lines, exhibits 7- and 15-db/mile loss, respectively, at this frequency. Given this attenuation, it was realized that special line amplifiers were necessary approximately every half to one mile along the cable to compensate for the rf losses.

Since the system operated only in channel T7, all line amplifiers were required to be bidirectional, simultaneously amplifying signals in both directions in the course of normal operations. This required the use of hybrid balancing transformers and circuits that required critical adjustments. These amplifiers were extremely sensitive to transients and standing waves on the cable. As the system grew, amplifier gain had to be set quite low (5 to 7 db) to keep the amplifiers from going into oscillations. If the gain was increased to allow for additional cable, the resulting oscillations would often cause the entire system to become inoperative.

During the installation phases, many man-hours were spent adjusting and balancing the cable network to provide maximum usable communications and monitoring capability. As the system grew, the problem of keeping the system cable network adjusted was so great as to almost require a man on site full time. With total dependence on Rockwell-Collins technicians for support and with the system likely to become unbalanced at any time because of cable breaks or amplifier gain shifts, the system was not dependable.

It became obvious that it would be impossible to live with this condition. Any cable break would result in such severe standing waves that oscillations would occur, and switching to a redundant loop-back cable for continued operation would not be possible. In addition, the low gain settings required the use of far too many amplifiers.

Because of this, the single-channel concept was reexamined and the benefits and drawbacks of one- and two-channel systems were considered in detail. A decision was made to convert to the two-channel system. The two-channel system incidentally, is the system discussed in detail in the previous operations and hardware sections. The discussion of the one-channel operation was omitted since it was only an early configuration and was not retained. The use of either a one- or two-channel system did not affect the operation of telephone devices.

As discussed earlier, the channels selected were T7 (5.75 to 11.75 MHz) and 1 (48 to 54 MHz) for signals inbound to and outbound from the system center, respectively. The line amplifiers were redesigned so that part of the amplifier handled channel T7 in one direction, and another part handled channel 1 in the other direction.

No bidirectional amplification was now required and 30 db of gain was usable with excellent stability. This higher gain more than compensated for the greater cable losses at channel 1. Also, because of the amplifier stability, standing waves have little effect, making cable loop-back possible.

In order to modify the telephones for two-channel operation, the hybrid transformers and associated circuits at the rf input were replaced with frequency translators (converters). The system center was also fitted with an up-converter to translate the outbound signals up to channel 1. Inbound signals remain as they were under the one-channel scheme.

The two-channel system conversion was performed at the completion of the final installation but prior to the add-on installation. In addition to the cable hardware and telephone changes performed to convert from a one-channel to a two-channel system, other enhancements were incorporated into the underground telephones. These enhancements were accomplished during the conversion and are summarized below:

- a. Holes were drilled in the bottom of the otherwise sealed case to allow for escape of gases that could possibly be vented from the internal batteries during recharging. This was a safety feature incorporated at the insistence of state inspectors and USBM and mine personnel with the concurrence of Rockwell-Collins engineering experiences.
- b. The switch located on the front of the telephones, used for activating the emergency portion of the emergency/paging transmitter, was replaced with a more rugged type. Several of the switch handles had been broken off, disabling emergency transmissions. Without the emergency transmit capability, a critical function of the system was not operable. In the interest of safety the switches were changed to increase the possibility of establishing communications during post-disaster situations.
- c. The underground telephones were originally identified with 5/16-inch high white stenciled numbers. Several complaints were received from mine personnel that in the limited lighting provided by a cap lamp, the numbers were not large enough to read. The telephones were renumbered with larger 5/8-inch-high digits.
- d. The telephones used in conjunction with the fan monitor and pump monitor/control units were modified to accept these devices. Spare telephones were also modified to provide a backup should either of these telephones fail.
- e. All underground telephones were modified and fitted with an additional circuit card that provided status monitoring of activation of the emergency switch and input power to the telephone. The on/off condition of the switch and the presence or absence of minimum proper operating voltage (33 v dc) were relayed via the telephone data link to the system center for matrix or teleprinter display. This feature would become a useful aid to identifying power distribution problems within the system.
- f. By breaking the seal of the underground telephones with the vent holes, the possibility arose that contaminants would get into and destroy the interior of the telephones. It was therefore necessary to protect internal components, and all circuit cards were sprayed with a sealer to extend operating life. This modification turned out to be unnecessary as the underground environment at Robena is relatively mild by mine standards. Internal heat in each telephone also helped to keep all components dry and free of corrosion. To date, no telephones have failed because of corroded components.

All of the aforementioned modifications helped to improve the overall system reliability and provide improved operation for the mine personnel. Additional modifications to the system included replacement of the surface telephone at the Slope hoist house with an underground unit and the repositioning of the TV camera. The environment in the hoist house was too severe for a surface telephone, causing frequent failures. The underground telephone, designed for use in harsh environments, was able to survive in the Slope hoist house and provides reliable service. Since the monitor/control unit could not be used to monitor and control the pumps at the A and B pump room, an agreement was reached with mine management to use the TV monitor system to observe the pump control panel. The control panel is composed of a series of lights and gages displaying such pump parameters as power being drawn, bearing pressure, float level, etc. The pump room is also well lighted. The TV camera was therefore positioned to provide a usable view of the pump control panel. The TV monitor, located on the surface in the superintendent's office, provides a continuous view of the status of the two pumps. Since repositioning the camera, the mine maintenance personnel have found the TV system to be a valuable asset in mine monitoring and a tremendous improvement over the previous pump monitoring method (that is, on/off status of power going to the pumping station).

During the initial phases of this program, all system maintenance was performed by Rockwell-Collins personnel who were on call to the site. However, as the USBM and mine personnel gained familiarity with the system and its operation, the maintenance responsibility was shifted. Since the conversion to a two-channel system early in 1976, there have been no cases where the system has failed requiring Rockwell-Collins to dispatch a man to the mine to

ascertain the problem. Problems have been limited to module or circuit card change level and periodic maintenance is performed by USBM personnel.

The USBM and the mine personnel were provided with system instruction manuals that detailed system and equipment operation and maintenance. Circuit cards and circuit components were forwarded to the mine to be used for repairing failed equipments. A three-day course was also held for a USBM technician at Rockwell-Collins Cedar Rapids, Iowa, facilities as an aid to improving the understanding of the system.

The only major problem remaining with the system has been that of power outages on the Colvin surface, causing the computer program to be lost. An uninterruptible power supply (UPS) system has been placed on order by the USBM. This system should drastically reduce the program interrupts. However, at this writing, the system had not been received at the mine.

5.2 Hoist Communications

An improved inductive hoist communications system was developed by the USBM under provisions of contract HO357148. This communication system was designed to provide reliable voice communications between a hoist operator and the hoist cage at all levels down to 10,000 feet.* Figure 5-35 shows a block diagram of the hoist communication hardware as it is used in a shaft. The system consists of two couplers and two transceivers. Each unit is of the push-to-talk, release-to-listen design. During transmission, the sending unit feeds the coupler with a frequency-modulated (FM) carrier at 52 kilohertz (kHz). The coupler induces a signal in the rope-shaft structure, which is then picked up by the coupler of the second unit. The two couplers are electrically identical, and each operates both as a transmitting and receiving element. Tests at several shafts had shown that signal losses at 52 kHz were small, and standing wave effects, which cause signal fade, were negligible. This resulted in high-quality voice transmission at all levels in the shaft. The most important feature of the design is the coupler, which was designed to achieve the maximum signal for a given transmitter power output.

First generation versions of this hoist communication system were installed in the Lucky Friday Mine in Mullan, Idaho, and the Grace Mine in Morgantown, Pennsylvania. The results of both installations were encouraging. Two of the second generation systems were installed at the Sunshine Mine in Kellog, Idaho. A set of the same equipments installed in the Sunshine Mine were installed at the Colvin portal of the Robena Mine complex.

5.2.1 Hardware Description

Figure 5-36 shows the hoist communication system hardware. The hoist-room station equipment is shown on the right and consists of a transceiver, battery charger with internal battery, foot operated push-to-talk switch, boom microphone, and surface (headframe) coupler. The cage equipment is shown on the left and consists of a transceiver, protective enclosure, internal battery, and elliptical coupler. Figure 5-37 shows the cage transceiver and battery as mounted in the protective enclosure.

*Regardless of whether or not the shaft contains metallic structures, cables, or conduit.

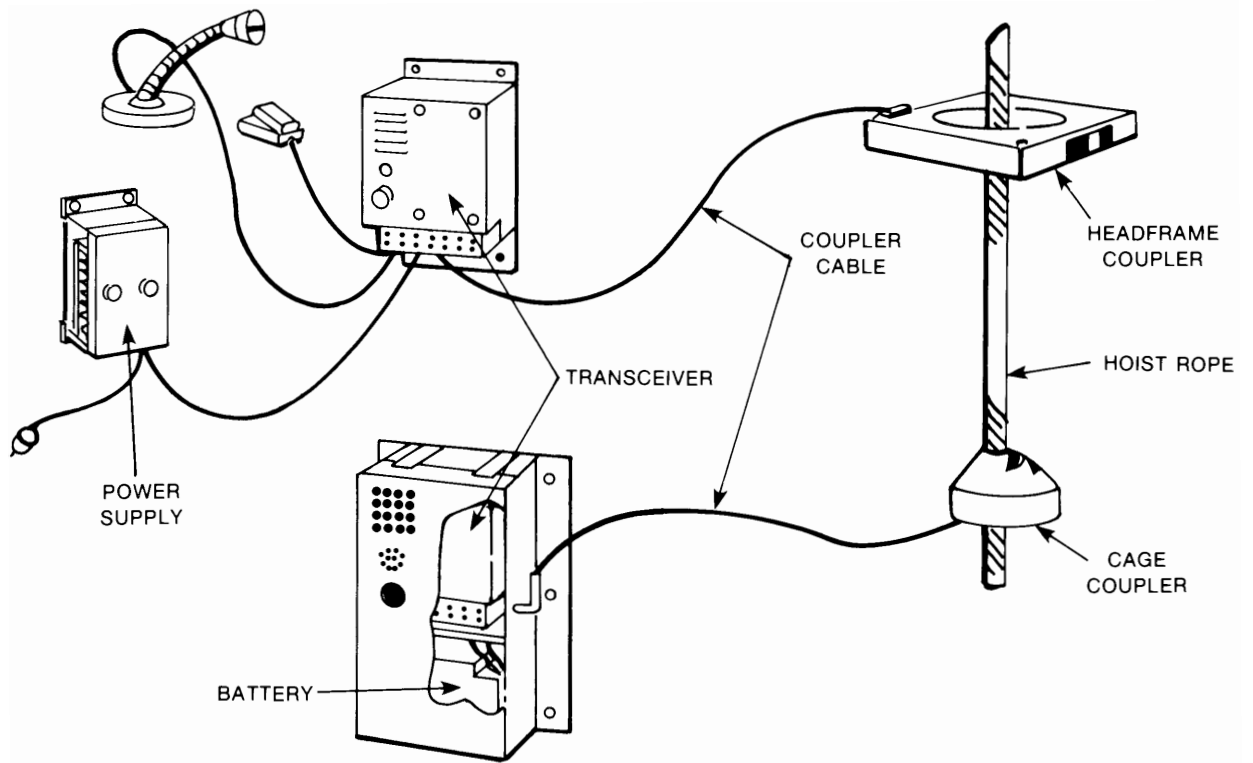

Figure 5-35. Block Diagram Showing Transceivers, Couplers, Hoist Rope and Interconnections.

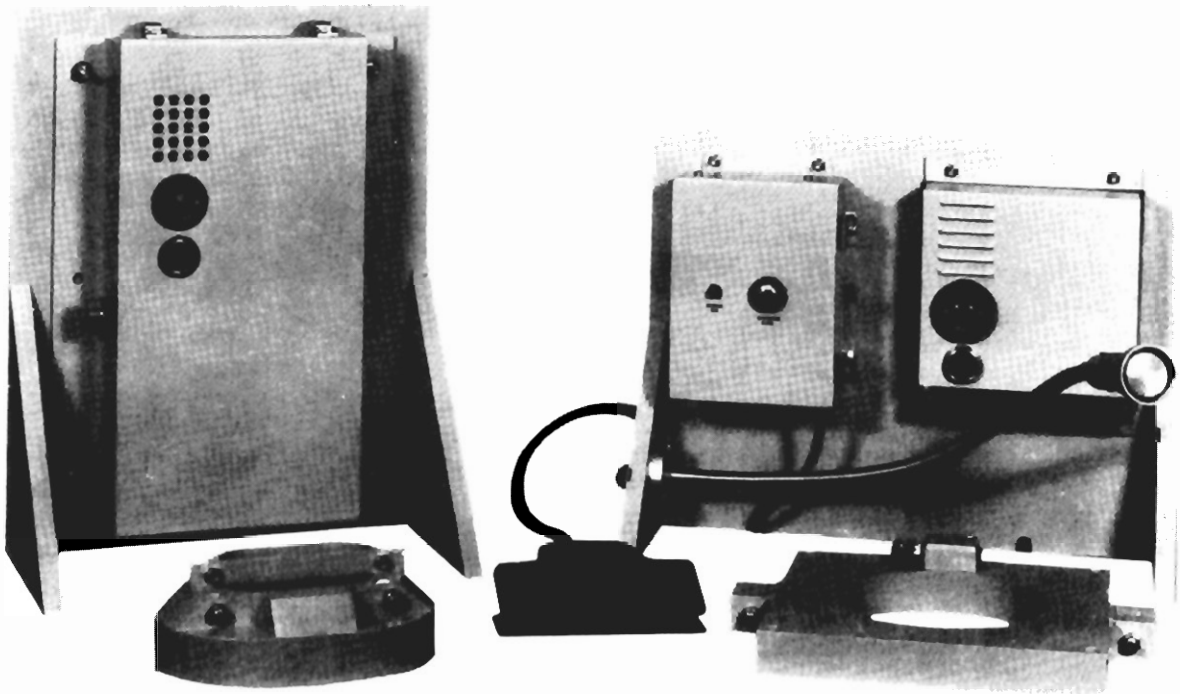

Figure 5-36. Hoist Communication System-Hardware.



Figure 5-37. Cage Transceiver and Battery in Protective Enclosure.

The protective enclosure is fabricated from angle iron, making it durable enough to protect the transceiver from the continual abuse experienced during loading and unloading timber, drill rods, and similar material being transported underground in a man-and-material cage. This protective housing encloses both the transceiver and battery in a compact, rugged unit which can be easily and quickly installed in the cage. When the transceiver is mounted in small cages where space is at a premium, the unit may be recessed in the cage wall without the protective enclosure, and the battery may be installed either above or below the cage.

A noise-canceling microphone, push-to-talk switch, and moisture-resistant speaker are mounted on the front panel of the unit. A provision is made for attaching a remote speaker for use in multideck cages. A common lead-acid motorcycle-type battery provides power. It is readily available locally and from mail-order catalogs. Battery life is at least 7 days.

All terminals on the cage unit are screw-type barrier strips for ease of installation, and threaded knockouts are provided on the protective enclosure for conduit. A remote handset input is available on the transceiver for use during shaft inspection and maintenance. Input terminals for a slack-rope-alarm switch are provided on the transceiver; the alarm signals the hoistman with an intermittent beep if there is slack rope, either intentionally or unintentionally.

The hoistman's transceiver is identical to the cage equipment except that the protective enclosure is not necessary for the surface installation. A combination power supply/battery charger powers the hoistman's unit and charges a spare hoist battery, which is exchanged with the cage battery on a weekly basis.

A foot-operated, push-to-talk switch located beneath the hoist console is the only operating control necessary. The hoistman is also provided with a boom microphone, which is positioned for his convenience.

5.2.2 Installation

The installation of the hoist communication system at Robena (Colvin shaft) was relatively straightforward. At the headframe, a bracket was made to securely hold the coupler around the rope and a twisted-pair wire cable was run from the coupler to the transceiver located in the hoist house. The transceiver in the hoist house was attached to a board located beside the hoist operator and fitted with the boom microphone and foot switch (figure 5-38). The power supply/battery charger was mounted on one of the walls in the hoist house near a 117-v ac outlet. A holder was fabricated for recharging the motorcycle battery and a cable was installed between the transceiver and the power supply/charger. This cable provided the dc voltage necessary to power the surface transceiver.

Another coupler was attached to the cable directly above the cage (figure 5-39), and a twisted wire-pair cable was run to the transceiver inside. The cage transceiver was recessed in such a way that no part of it projected (figure 5-40). This was necessary because the cage is used not only for men but also material and rail cars loaded with supplies are often taken up and down the shaft. Recessing the transceiver protects it from material that may project from the cars. The protective enclosure was mounted on the cage top and used to house the battery and a remote handset. Conduit was installed between the enclosure and the transceiver to protect power and handset interface wiring.

At the completion of the installation, the system was tested and proved to be operating perfectly. The voice quality on the hoist communication system is excellent. Even when the volume is set high, there is little distortion. Since this system was designed to operate up to 10,000 feet, it is not surprising that it operates so well on the 420-ft cable of Colvin shaft. The personnel who work around the shaft comment that the only time there is any interference is when a rotary dump on the tippie is in operation. The problem is electromagnetic interference (EMI) from the motors and control relays associated with this dump.

5.2.3 Follow-On Maintenance and Support

One major problem developed with the hoist communication system, that of cage transceivers failing. The problem was traced to components and circuit boards physically shearing from their mounts. This failure was a result of the tremendous shock encountered when the cage is set on the shaft bottom. At the Robena Colvin shaft, there is a platform at the bottom wherein the cage when lowered to shaft bottom, rests on this platform. The hoist communication system had been developed for deep shaft mines with multiple levels, where the cage never rests on the bottom. It was, therefore, necessary to modify the cage transceiver to



Figure 5-38. Hoist Room Transceiver With Boom Microphone.

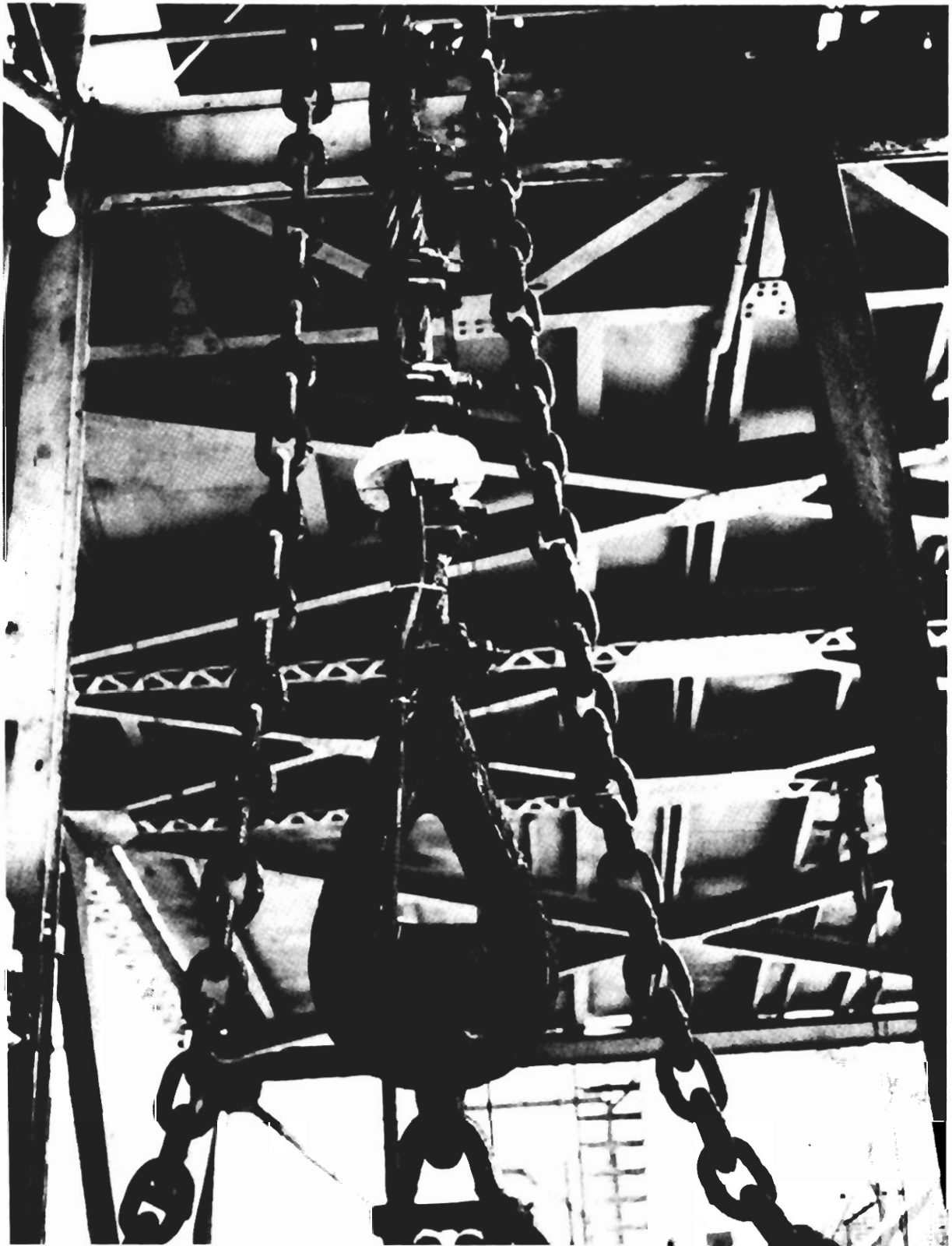

Figure 5-39. Cage Coupler Installation.

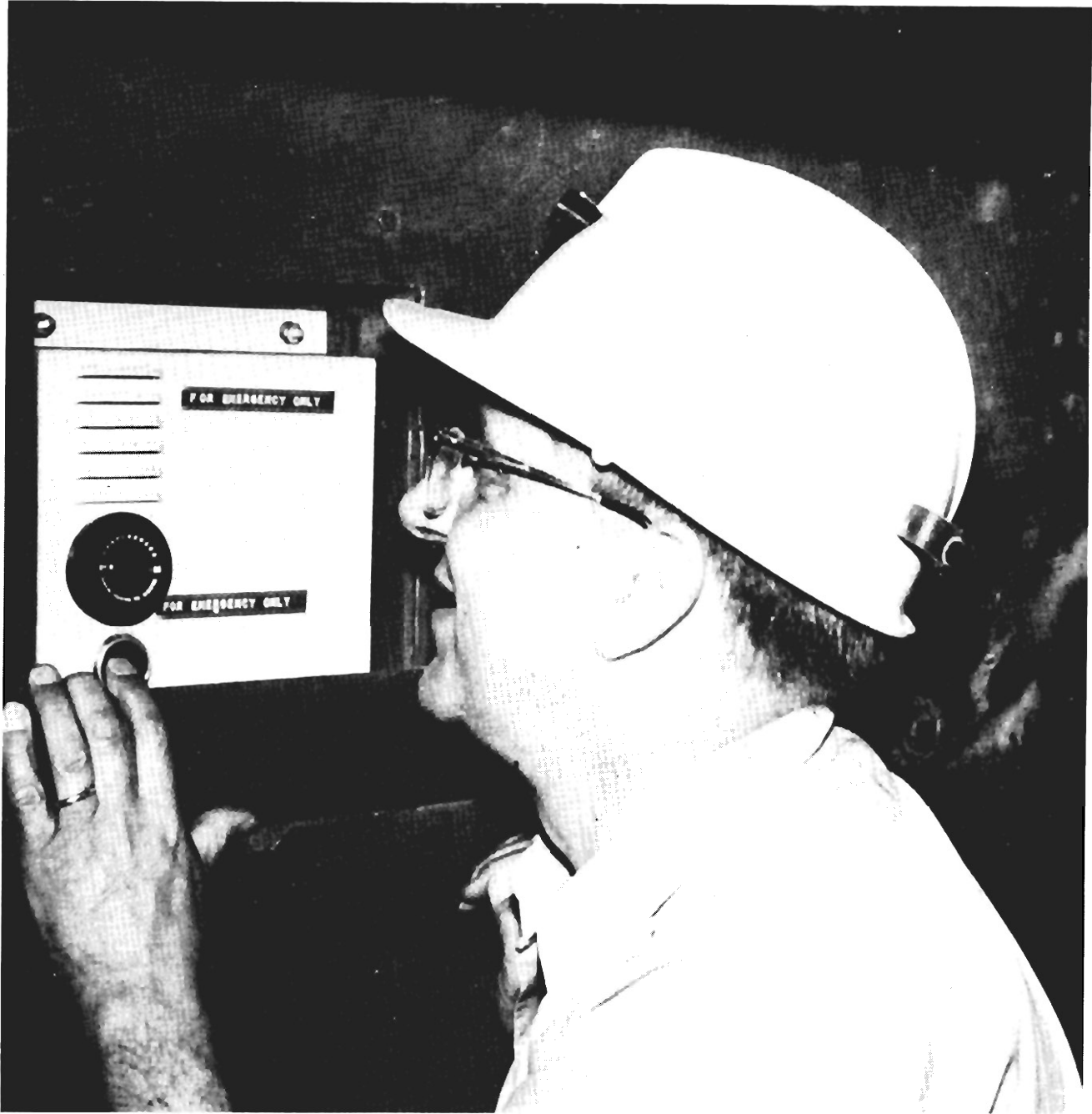

Figure 5-40. Cage Transceiver Installation.

survive this shock environment. The circuit boards were reinforced and braced up and components susceptible to shearing were secured with silicon rubber adhesive. This reduced the failure incidents but did not completely cure the problem. The next step would have been to shockmount the entire transceiver.

The viability of using a communication system on the Colvin hoist was successfully demonstrated; however, the original intent of the system (shaft inspections) was never implemented. The mine personnel preferred to use the hoist communication system as an emergency system, relying on their former methods of signaling. This indicated that the system would gain greater usage as a demonstration installation elsewhere.

6.0 RECOMMENDATIONS/CONCLUSIONS

A whole mine, computer-controlled communication and monitoring system for both normal and emergency use is installed and operating in the US Steel Robena Mine complex. This system satisfies the objective of demonstrating an integrated communication and monitoring system that allows private telephone channels, environmental monitoring, personnel paging, emergency communications, and control of underground equipment, all on a single coaxial cable. Worker and management acceptance of the system has been excellent, and the system is expanding to keep pace with the demands of new mine development. A hoist communication system has provided the voice communications necessary between the hoistman and the cage for a safe and efficient hoisting operation.

The Engineering and Administrative Services Program, in conjunction with other US Bureau of Mines sponsored programs, has resulted in significant improvements in mine communications and monitoring. Since the installation in the Robena Mine complex, several other mines have installed, or are going to install, similar systems to meet critical communications and monitoring needs. The USBM has also installed a smaller version of the system (that has increased capability) in its research facilities at the Bruceston test mine near Pittsburgh, Pennsylvania. Identical copies of the hoist communication system have been installed at the Sunshine Silver Mine in Big Creek, Idaho, also under provisions of the Engineering and Administrative Services Contract SO133035.

Tours have been conducted at the Robena Mine so that interested personnel from other mines and equipment manufacturers could witness, first hand, the performance of the communications and monitoring system and confer directly with the users of the system.

Through various Bureau of Mines sponsored technology transfer seminars, the information gathered at the Robena Mine complex has been presented to other mine owners and operators in an effort to promote the use of this technology. US Steel and Rockwell-Collins have taken an active role in these seminars, providing first-hand design, installation, and maintenance experience.

The basic goals at the Robena Mine complex were to provide wireless, carrier and audio voice channels to improve communications between sections and to the surface, both via waveguides and through the earth. Additionally, data telemetry systems were to be included that would relay environmental parameters from selected transducers in the working places to the surface as well as providing fan signaling systems. The communications and monitoring and the hoist communication systems, installed and maintained under provisions of USBM Contract SO133035 have been the means of satisfying these goals. Since the initial site survey in July 1973 through to system acceptance in December 1976, there has been strong cooperation between the USBM/Rockwell-Collins team and the mine. Were it not for the support of the improvement goals by US Steel and Robena personnel, this program would have failed. Because of this support and the determination to complete the program, all phases of the project have had favorable results.

The communications and monitoring system has enhanced the capability of previous systems as well as providing new and expanded functions. The general opinions of the mine personnel who use the system on a day-to-day basis have been extremely encouraging. The voice channels are clear no matter how far away the communicating telephones may be. In some instances, this distance is almost 10 miles. There is no hum or static on the line and no degradation due to seasonal effects. Many benefits have been realized by mine management in the ability to contact personnel more rapidly. It is difficult to measure improved productivity or safety, but there is little doubt that improvements do exist. When supervisors can quickly and clearly contact underground sections, when a part can be called for

without error, when incoming messages can be relayed from telephone to telephone automatically -- these things add up quickly.

It is interesting to note that the operations personnel always use the communications and monitoring system when given a choice. They also did not tolerate lengthy shutdowns during system modifications when the system center was sometimes turned off. This is a most meaningful measure of what the system does for daily operations.

In one instance, a false alarm from an existing independent monitoring unit on the Willow Tree fan had caused power to be shut off underground. This caused all underground telephones to switch to battery power and this event was duly printed out by the teleprinter. Mine personnel quickly returned all power (or so they thought) underground. However, the teleprinter continued to indicate that telephones in one area of the mine were still operating on battery power contrary to what was thought. A check of that area showed that power was not on, a situation that was easily detected by the system.

In addition to improvements offered by the basic telephone operation, mine personnel make extensive use of the radio interface and TV monitor systems. Although not implemented as originally intended, these systems increased the overall communications and monitoring capability of the mine. In the case of the radio interface, necessary maintenance supplies are easily located through a roving surface supply man. The TV system provides a visual indication of the status of the two pumps used to remove all of the water from the mine.

One advantage not easily perceived but definitely experienced, is that with the introduction of the new telephones, the operator function of the dispatcher is greatly reduced. This allows for more concentrated effort on vehicle movement and thus coal removal. All areas of the complex, however, were not implemented with new telephones so some operator activity is still required of the dispatcher.

Some of the features of the communications and monitoring system, unfortunately did not operate as well as desired. These features are the environmental monitoring and the personnel paging. The environmental monitors being a prototype design, were relatively crude. The monitors tended to be temperature and humidity sensitive and required rather frequent (bimonthly) calibration to ensure accurate readings. The calibrations were too numerous for USBM and Rockwell-Collins to do on a periodic basis, and the mine was unable to assume the responsibility because of mine maintenance duties. The pocket pagers associated with the personnel paging system were also a prototype design, packaged in a heavy steel box. These pagers were inconsistent from unit to unit in their operation, tending to be unstable, responding to the wrong pages or not responding at all. The pager was later redesigned with an improved superhetrodyne circuit that resulted in improved stability and increased reliability. However, the case was still too heavy (2.2 pounds) for a miner to add to his collection of necessary hardware.

Both system features, as a result of their shortcomings, were slowly phased out of operation at Robena. In the interest of maintenance simplicity, it was recommended toward the end of the program, that these two features be deleted from the system operation at Robena. Prior to this recommendation, sufficient data had been compiled to verify that environmental

monitoring and personnel paging were viable functions for a mine communications and monitoring system.* The primary goal of the program has in fact been accomplished, that of demonstrating operational concepts for mine owners and operators.

Additionally, it was shown that a one-channel scheme was not practical for a system requiring the extensive cable network of a coal mine. This problem, however, was detected early in the program where corrective action could be taken. The conversion to a two-channel system not only increased reliability and improved maintenance but provided the capability for implementing multiple loop-back paths as well.

The experiences at Robena have also led to several improvements to the communications and monitoring system. These improvements include the modularization of the underground telephones for reduced unit cost and increased functional capability, the design of new monitor/control devices for increased total capability, the diversification of the environmental monitors into individual functions for improved flexibility during implementation, and the redesign of the system center to be completely redundant for improved reliability. Additional enhancements are improved operating software with greater functional and diagnostic capability, and the production of more easily maintained equipments. Although not implemented into the Robena system, these improvements are part of the communications and monitoring system as presently configured.

In addition, the down-sized version of the Robena communications and monitoring system installed at the USBM test facilities at the Bruceton test mine demonstrated an interesting feature not available at the time of the Robena installation. This feature is the ability to interrogate environmental parameters via through-the-earth signals. Through-the-earth environmental monitoring was conceived to be a useful postdisaster function for determining the condition of an underground environment prior to rescue operations. For this operation, a modified telephone and three-function environmental monitor are interfaced with a through-the-earth receiver/control unit (separate box). A low-frequency (990-Hz) signal is used to trigger the receiver. The receiver/control unit detects the signal and turns the telephone and monitor power on (assuming they had been powered down by the receiver/control unit following a disaster), allows them time to warm up then interrogates the environmental sensors. Using the emergency/paging transmitter in the telephone, the receiver/control unit transmits this environmental information to the surface for detection by special receivers. The telephone and monitor are then powered down to await the next interrogation from the surface. Units of this type were installed and tested at the Bruceton Mine as well as at Robena. Preliminary test results indicated that the through-the-earth interrogation of environmental parameters was a viable concept requiring further investigation.**

*"59D-1 Call Alert Receiver Remote Paging System, Preliminary Evaluation" prepared for the USBM by Collins Commercial Telecommunications Division, Rockwell International, under provisions of contract SO133035, and "Mine Communication and Monitoring, Final Report" prepared for the USBM by M.D. Aldridge, R.E. Swartwout, W.W. Cannon, N.S. Smith, and D.T. Worrell at West Virginia University under provisions of grant GO101702 (MIN-39).

**For further information, refer to "Design and Development of Up-Link Environmental Monitor" final report prepared for the USBM by Collins Commercial Telecommunications Division, Rockwell International under provisions of Contract HO357146.

The hoist communication system, intended to replace the whistle signaling method of communicating for shaft inspections, was successfully demonstrated but never completely accepted by the mine. The mine personnel preferred to use the hoist communication for emergency purposes, relying on the old whistle method as being verified reliable. Human error notwithstanding, the whistle method does work and requires minimal maintenance to ensure reliable operation. The demonstration of improved hoist communication systems was much more successful at the Grace Iron Ore and Sunshine Silver Mines.

The importance of periodic maintenance cannot be overemphasized. Underground and surface mine environments are especially harsh and equipments expected to survive require special packaging. Combined with adequate protection, routine maintenance of all equipments is necessary to ensure long-term reliability.

The maintenance schedule established at Robena on the communications and monitoring and the hoist communication systems exposed potential problems before they affected system performance. Periodic performance tests, accomplished by USBM and Rockwell-Collins personnel, also helped to identify trends in system operation in an effort to correct long-term problems.

In summary, the communications and monitoring system provided improved communications and monitoring to the Robena Mine complex, increasing safety and improving production. The system is presently being modified to eliminate the environmental monitoring and paging functions to simplify maintenance for mine personnel. A battery backup system has been procured by the USBM to allow the entire system to be self-sufficient during power down or disaster situations. Spare components were forwarded to the mine to aid in equipment repair and maintenance. The hoist communication system is being removed for relocation to another site. Reliable operation of both systems can be expected for several more years.

7.0 EQUIPMENT SPECIFICATIONS

7.1 Communications and Monitoring System

The electrical and mechanical specifications of the communications and monitoring system are listed below:

System Electrical:

Frequency:	5.75 to 11.75 and 48 to 54 MHz.
Traffic capacity:	298 communication channels of 10.0615 kHz each.
Frequency response (audio):	300 to 3000 Hz \pm 3 db.
Noise:	Less than 30 dbrnc.
Harmonic distortion (audio):	Less than 5%.
Differential delay:	400 μ s at 750 to 3000 Hz. 1000 μ s at 300 to 3000 Hz.
Crosstalk:	-50 db.
Information Tones:	
Dial:	Continuous 355- and 450-Hz tones modulated with FDM channel 290 (7.3751 MHz).
Ringback:	Repeated duty cycle of 2 seconds on, 4 seconds off with 450- and 520-Hz tones modulated with FDM channel 296 (7.3147 MHz).
Invalid:	Alternated 355- and 520-Hz tones every 1/2 second, modulated with FDM channel 293 (7.3449 MHz).
Busy:	Repeated duty cycle of 1/2 second on, 1/2 second off with 355 and 450 Hz tones modulated with FDM channel 284 (7.4355 MHz).
Preempt:	Program selected FPM channel modulated with an unrepeated 980-Hz tone burst of 1/2-second duration.
Done:	Program selected FDM channel modulated with an unrepeated pair of tones (1/2 second of 980 Hz followed by 1/2 second of 700 Hz).
Control signal:	300 mv at 10.625 MHz (up-converted to 53.125 MHz), 30% amplitude modulated with the 80-kb/s Manchester-encoded control data.

Monitor signal:	70 mv at 7.083 MHz, keyed with the 80-kb/s monitor data consisting of a 20-bit preamble of logic 1's (carrier) followed by a 36-bit monitor word.
Battery power:	In the event of underground power failure, the underground equipments are equipped with internal battery backup and will operate for at least 24 hours on these batteries.
Power Consumption:	
System center:	13 amps at 117 v ac.
Surface telephone:	150 ma at 28 v dc.
Underground telephone:	
(Min)	150 ma at 48 v dc
(Max)	400 ma at 48 v dc
3-function environmental monitor:	200 ma at 28 v dc
Fire monitor:	50 ma at 28 v dc
Monitor/control unit:	75 ma at 28 v dc
Escapeway receiver:	75 ma at 28 v dc
Radio interface:	2 amps at 48 v dc
Line amplifier:	350 ma at 48 v dc

Mechanical:

	<u>Size (in)</u>	<u>Weight (lb)</u>
System center:	23.0 x 27.0 x 64.0	200.0
Surface telephone:	9.4 x 8.6 x 5.0	4.5
Underground telephone:	21.0 x 7.6 x 10.0	26.0
3-function environmental monitor:	6.0 x 4.0 x 16.0	9.2
Fire monitor:	6.0 x 5.0 x 3.7	2.0
Monitor/control unit:	7.5 x 6.0 x 4.25	4.0
Escapeway receiver:	6.0 x 6.0 x 3.0	5.0
Pocket pager:	6.5 x 3.5 x 1.0	2.2

	<u>Size (in)</u>		<u>Weight (lb)</u>	
Radio interface:	22.3 x 28.3 x 12.25		225.0	
Line amplifier:	18.6 x 9.5 x 5.75		24.0	
Line amplifier battery:	11.75 x 8.0 x 4.75		18.5	
Coaxial Cable Specifications:				
	<u>7/8-inch</u>	<u>0.412-inch</u>	<u>RG11</u>	<u>RG59</u>
Attenuation at 10 MHz: (db/100 ft)	0.145	0.32	0.66	1.10
Attenuation at 55 MHz: (db/100 ft)	0.36	0.75	1.55	2.35
Loop resistance: (ohms/1000 ft)	0.50	2.24	7.75	53.60
Impedance (ohms):	75.00	75.00	75.00	75.00
Cable weight (lb/1000 ft)	300.00	80.00	96.00	32.00

7.2 Hoist Communication System

The electrical and mechanical specifications of the hoist phone system are listed below:

Electrical:

Frequency:	52 kHz.
Modulation:	Narrow-band FM (12F3), ± 3 -kHz deviation.
Supply voltage:	12 v dc, battery operated. 5-amp-hr sealed lead acid battery or 12-v dc dry cell. Burgess Type TW2 or equivalent.
Current drain:	35 ma standby; 35 ma receive (handset); and 210 ma transmit.
Operating time:	180 hours (10% RX, 10% TX, 80% standby with 12-amp-hr battery).
Transmit power output:	0.5 watt into 4.7-ohm resistive load.
Frequency stability:	± 0.25 percent.
Coupler output:	1.0-v ac induced voltage into 1 turn link secondary.
Sensitivity:	10 microvolts for 20-db quieting.

Squelch: Operates at less than 10 microvolts.
 Selectivity: -60 db at ± 20 kHz.
 Audio output: 0 dbm into handset, 2 watts into 8-ohm speaker.

Mechanical:

	<u>Size (in)</u>	<u>Weight (lb)</u>
Transceiver:	12.6 x 9.4 x 5.8	13.2
Battery charger:	6.0 x 6.0 x 2.4	3.6
Speaker:	6.5 x 4.5 x 2.6	3.4
Headframe coupler:	11.0 x 11.9 x 1.5	16.4
Cage coupler:	3.4 x 6.0 dia	12.5
Carrying case:	23 x 13 x 10	10.7

8.0 COMMUNICATIONS AND MONITORING SYSTEM PERFORMANCE TESTS

Tests were performed on all equipments at Rockwell-Collins prior to system installation. These tests included individual component and system evaluation to verify proper operation. As the equipments were installed, they were again thoroughly tested. Any equipment that failed to meet minimum performance standards was returned for immediate repair. Logbooks were kept of all repairs and tests to be used for reliability and performance tracking. High numbers of common failures were traced and corrective action taken.

During the course of system installation several checks were also made to ensure continued system operation. These checks included the following:

- a. Periodic random calling to ensure clear connections with no misplaced or dropped calls.
- b. Exercise of telephone features to verify proper operation, that is, call forward, conferencing, priority interrupt, party line, and consultation hold.
- c. Periodic individual and all call paging to underground work parties equipped with pocket pagers.
- d. Removal of underground power to check operation of equipments on battery power (at least 8 hours).
- e. Activate emergency/paging transmitters and verify operation.
- f. Calibration checks of environmental and equipment monitors verifying the local display and surface display/printout.
- g. "Break" the cable in the loop and verify operation of loop-back function.
- h. Periodic diagnostic tests of all telephone instruments.

These checks were a means of verifying the overall operation of the system and of locating and identifying problems. Records were kept of all checks and compared with previous data to determine trends in operation.

At the completion of the installation, extensive tests were performed on the system that concluded with a formal demonstration and system acceptance during December 1976. The USBM, US Steel management, Robena, and Rockwell-Collins were represented. A summary of these tests and the results are outlined below:

8.1 Tests Performed

- a. Rf signal strength - Using an rf field strength meter, the 33.125-MHz control frequency level in dbmv at the input to each telephone instrument was measured and recorded. Tolerance: +17 dbmv \pm 7 db.

<u>PHONE NUMBER</u>	<u>LOCATION</u>	<u>SIGNAL STRENGTH (dbmv)</u>
1001	Colvin Superintendent	18
1002	Colvin Mine Foreman	18
1003	Colvin Maintenance Foreman No. 1	17
1004	Colvin Maintenance Foreman No. 2	17
1005	Colvin Map Room	17
1006	Colvin Mine Rescue	16
1008	Colvin Supply House Front	11
1009	Colvin Supply House Back	18
1010	Colvin Shaft Top	18
1011	Colvin Outside Shop	18
1012	Colvin Car Shop	18
1013	Colvin Hoist House	19
1014	Colvin Electrical Shop	18
1114	Colvin Hoistman's Stand	19

<u>PHONE NUMBER</u>	<u>LOCATION</u>	<u>SIGNAL STRENGTH (dbmv)</u>
1101	Garards Fort Superintendent	25
1102	Garards Fort Maintenance Foreman	21
1103	Garards Fort Mine Foreman	21
1104	Garards Fort Supply Clerk	21
1201	Slope Superintendent (lab)	17
1202	Slope Screen House	28
1203	Slope Hoist House	18
1204	Slope Plant Foreman	17
1205	Slope Maintenance Foreman	15
2001	Willow Tree Fan House	9
2002	3 Right	Not available
2003	7 Chute	Not available
2004	4 Right	Not available
2005	2 Left	Not available
2006	Demo Phone	18
2007	Slope No. 1 Right	27.5
2008	Booster Pump	17.5
2009	13 Chute Pump Room	22
2010	A&B Pump Room	17.8
2011	Colvin Dispatcher	15
2012	Slope Middle Chute of 5	18.5
2013	Slope No. 5 Side Track	26.3
2014	Grease Track	27.8
2015	Slope No. 13 Chute	16
2016	Slope Dumps	21.7
2017	Colvin 5 Chute	20.5
2018	Rock Section	21
2019	1 Back Action	19
2020	Willow Tree 2 Panel	Not available
2021	Willow Tree 8 X Cut	17.3
2022	Willow Tree 31 X Cut	23
2023	Willow Tree Left (101 Brato)	22.3
2024	Craty Borehole	19
2025	Willow Tree Right Side	11
2026	Willow Tree 3 Panel	Not available
2027	Willow Tree Flats	-5
2028	103 Switch House	15.3
2029	Colvin Bottom	17
2030	Willow Tree 85 X Cut	18.5
2031	Willow Tree Breaker Room	19.5
2032	Colvin 69 X Cut	15.3
2033	Colvin 51 Chute	21
2034	Colvin 47 Chute	15.5
2035	Colvin 1 Butt	17.5
2036	32 Shanty	18.5
2037	Colvin Motorbarn	19.8
2038	1 Butt 11 Room	22
2039	5-85 Radius	22
2040	1 Side Track Lower End	24
2041	Garards Fort 1 Left	28.5
2042	Garards Fort 3 Right	28
2043	Garards Fort Top No. 2 Side Track	22.5

<u>PHONE NUMBER</u>	<u>LOCATION</u>	<u>SIGNAL STRENGTH (dbmv)</u>
2044	Garards Fort Motorbarn	20.8
2045	Garards Fort Borehole	21.8
2046	Garards Fort 5 Right	26
2047	Garards Fort 4 Corners	26.5
2048	Garards Fort Dispatcher	22
2050	Colvin Supply House	18
2400	Coupler Interface	19

- b. BER tests - A bit error rate (BER) test was performed on each telephone instrument. A BER test is performed from the system center and is initiated by typed commands on the teleprinter. A device being tested is taken out of service via a teleprinter command and requested its digital status. This status is printed by the teleprinter and stored in computer memory. Initialization of the test begins when this digital status is typed back into the teleprinter with a start code. The computer then requests the devices status 10,000 times, compares these 10,000 responses with the initial status and prints out the errors received by category, (that is, no responses, wrong response, etc). It takes approximately 3 to 5 minutes for each test. Errors in excess of 1 percent (100) are considered abnormal and should be corrected.

All telephone instruments at Robena were tested with the highest error response being 0.27 percent (27) in any one category. Most instruments had less than 0.01 percent (1) errors out of the 10,000 status requests. It should be noted that the BER test was a useful tool to locating and correcting faulty telephones and cable network problems during the installation phases.

- c. System operation verification - The following system operating features were checked and verified:
1. Surface telephone call operation - Calls were randomly initiated between telephones at all surface sites to telephones at that same site and all other sites with 100 percent success.
 2. Function tests - The conferencing, call forwarding, priority, interrupt, consultation hold, party line, and call transfer features were tried between random surface and underground telephones specifically classmarked for the functions. All features tested correctly with no errors being reported.
 3. Underground operation tests - At all underground telephone locations, the monitor emergency/paging, battery, and telephone operations were tested. Some failures did occur but were noted and later corrected. In addition, random pocket pagers were tested, but with not too favorable results. The pagers suffered from mispaging or not paging during the tests. At this writing the pocket pagers were redesigned by the manufacturer to correct these deficiencies, but no test data is yet available.
- d. System battery operation - All underground power to the communications and monitoring system was removed. Random telephones were then used to place calls to locations throughout the system. The system was allowed to be on battery power for 8 hours, retested, and returned to cable power. No degradation was experienced during the battery operation.
- e. Loop-back test - At a point within the loop, the cable was "broken" and the system was checked for any loss of service. The only notable peculiarity was that some telephones located long distances from the system center had a weaker rf signal, the additional cable in the loop-back region and the unbalanced amplifier gains on the loop-back path. The signal was, however, sufficient for a clear voice path and would be adequate until a cable break could be repaired.
- f. TV monitor - The TV monitor was observed and found to have excellent video quality.

8.2 Hoist Communication System Performance Tests

Performance tests were made at Rockwell-Collins on the hoist communication system prior to installation. These tests included individual component as well as integrated system tests. After installation, tests were again performed to verify proper operation of the system. The system was then put into service and not retested until the system demonstration and acceptance in December 1976. The tests performed for this demonstration and acceptance were more extensive and included the following:

- a. Receiver sensitivity
- b. Transmit frequency
- c. Transmit power
- d. Dc current drain
- e. System talkout

The data from these tests is listed below:

Receive sensitivity (20 db quieting)

Cage transceiver - not available
Hoist transceiver - not available

Transmit frequency (52 kHz \pm 50 Hz)

Cage transceiver - 51.986 kHz
Hoist transceiver - 52.003 kHz

Transmit power (1.5 v ac \pm 0.1 v across 4.7-ohm resistor)

Cage transceiver - 1.45 v ac
Hoist transceiver - 1.425 v ac

Dc current drain (ma dc)

	<u>Squelched</u>	<u>Receive</u>	<u>Transmit</u>
Cage transceiver	42	480	220
Hoist transceiver	44	540	220

System talkout - Check okay, excellent audio quality for the entire travel of the cage.

SECTION II

A Communications and Monitoring System for an Underground Iron Mine

Grace Mine

1.0 INTRODUCTION

The Coal Mine Health and Safety Act of 1969 authorized the United States Bureau of Mines to undertake research that would lead to increased safety in mines. This research included the development of new or improved means and methods of communications during normal day-to-day and emergency situations.

This section of the report (Section II) describes the efforts to provide improved communications at the Grace Iron Ore Mine, located in central Pennsylvania.

2.0 GRACE MINE DESCRIPTION

The Grace Iron Mine and Mill, owned by Bethlehem Steel Corporation and operated by Bethlehem Mines Corporation, is located approximately 2 miles north of Morgantown, Berks County, Pennsylvania.

The mined product at Grace Mine is a "rich" grade of magnetite ore. The magnetite is characteristic of the type found at the nearby Cornwall Mine, also owned by Bethlehem Steel Corporation. Mineralization has replaced a Cambrian limestone lens isolated between Triassic diabase footwall and Triassic sedimentary rock hanging wall. The kidney-shaped orebody dips to the northeast at 30° and then strikes northwest, southeast. Average thickness of the orebody is 300 feet and strike width is 1,200 feet. First ore occurs about 1,500 feet below the surface.

The orebody consists predominantly of magnetite and irregularly distributed zones of hydrous calcium-magnesium silicates, scattered lenses of limestone, and a few veins of milky quartz. The ore, while typically moderately friable and easily broken when struck with a hammer, can range from very crumbly to very hard. Specific gravity of the ore ranges from 3.0 to 4.7 and averages 3.6. Porosity is about 14 percent.

The mine size is approximately 3,000 by 1,500 feet on the sixth production level (figure 2-1). The active production occurs on this level and is from 2,400 to 2,800 feet below the surface. All haulage drifts and mobile equipment runways are 12.5 feet wide and 10 feet high. These runways and drifts are located in the rock just below the orebody and can reach a gradient of 20°.

The magnetite ore, of approximately 40-percent iron content, is mined by a modified block caving system (fan hole, figure 2-2) and transported to a collection point with large (2-, 5-, and 8-cubic-yard) rubber-tired diesel-powered load-haul-dump (LHD) vehicles (figure 2-3). All underground transportation is accomplished using diesel-powered vehicles. The magnetite is then crushed to minus 5 inches by crushers located underground and moved by conveyor belt to storage bins at the shaft. All ore presently exits the mine through a shaft via the sixth production level. Prior to the changeover on the sixth level to rubber-tired diesel vehicles, trolley-operated locomotives were used for haulage on the upper levels. Two circular, concrete-lined shafts serve the mine in order to provide access for men, material, and air.

One shaft (A) is used primarily for ore and waste removal as well as providing access for maintenance personnel and material. The second shaft (B) is used only as access for men and materials. All fresh air enters the mine through shaft B and is exhausted out shaft A. The air underground is circulated using strategically located fans.

The magnetite is loaded automatically into 20-ton skips and hoisted approximately 2,500 feet to the headframe storage bins. The ore is then conveyed to the secondary crusher on the surface where it is crushed to minus 3/4 inch with two cone crushers. Continued grinding and further separation of ore and waste rock occur in the mill where rod and ball mills grind the magnetite to +60 percent minus 325 mesh and where the magnetite and waste rock are separated with the use of magnetic separators.

The magnetite is then pumped to the pellet plant, dried, dropped into rotating cones to form 1/2-inch pellets, moved into one of the six shaft-type furnaces, and heated to produce a product that is uniform and, after cooling, hard. A day's production of pellets is held in a storage bin and loaded into hopper cars for daily rail shipment to Bethlehem Steel Mills.

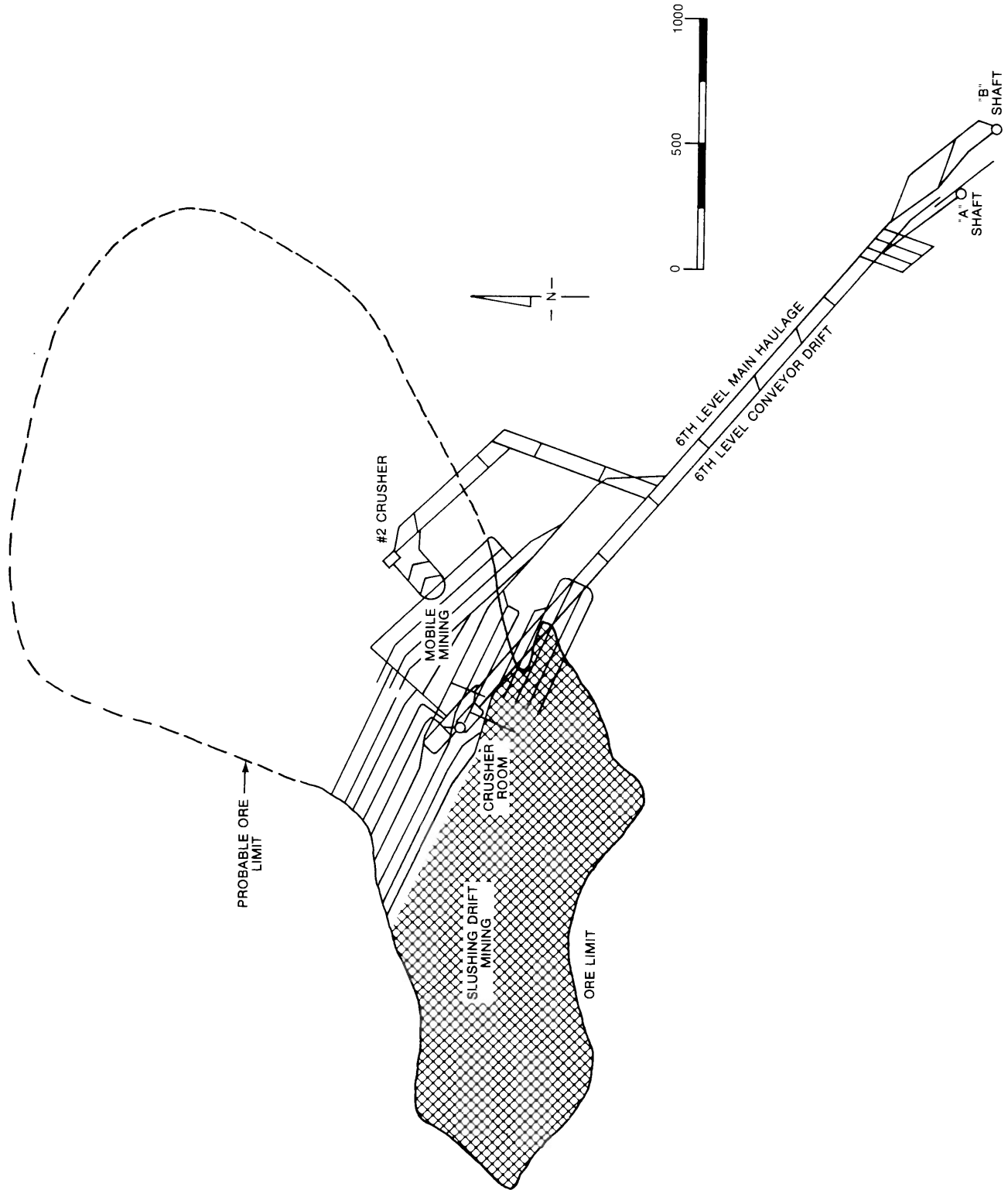

Figure 2-1. Plan of Grace Mine Orebody.

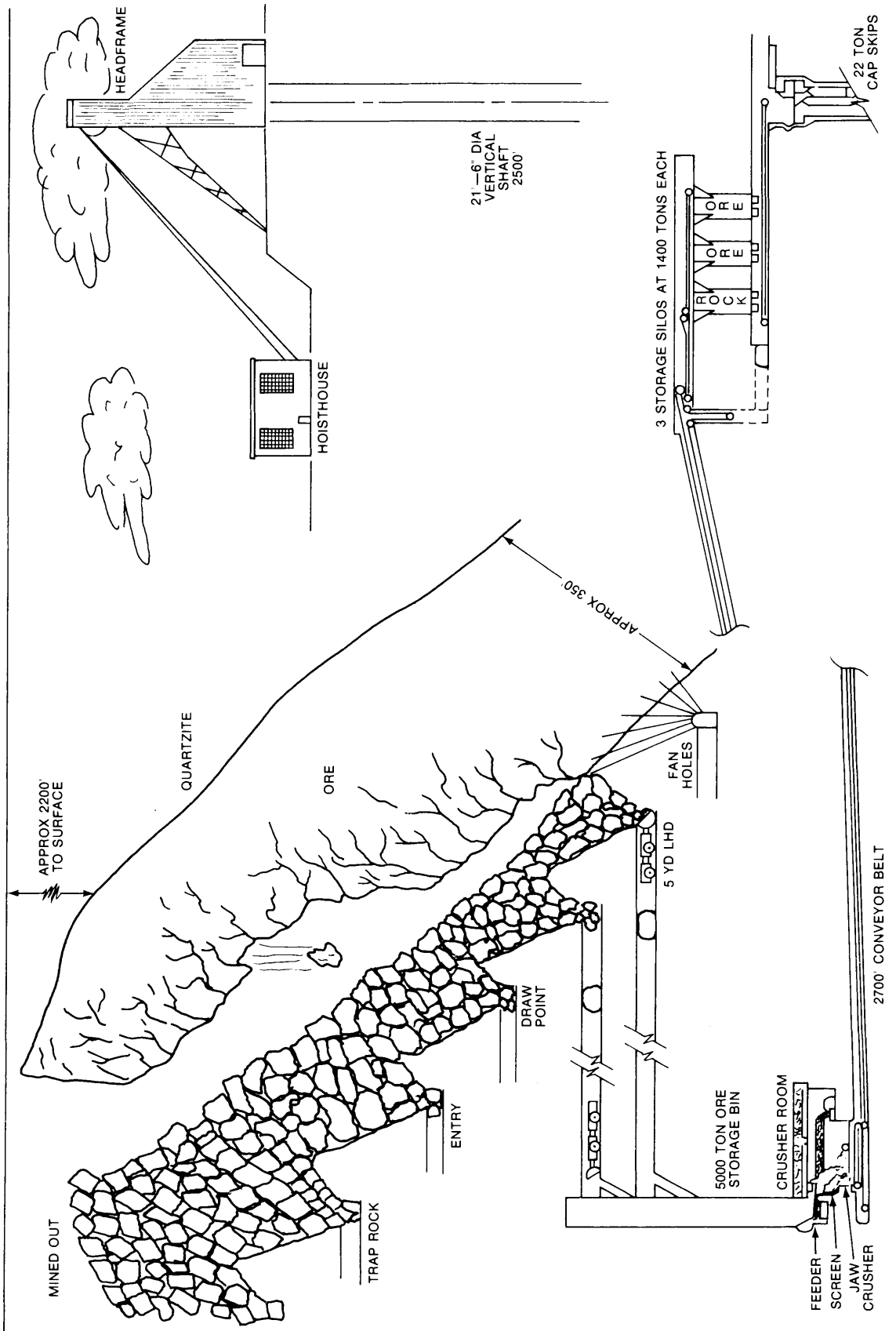
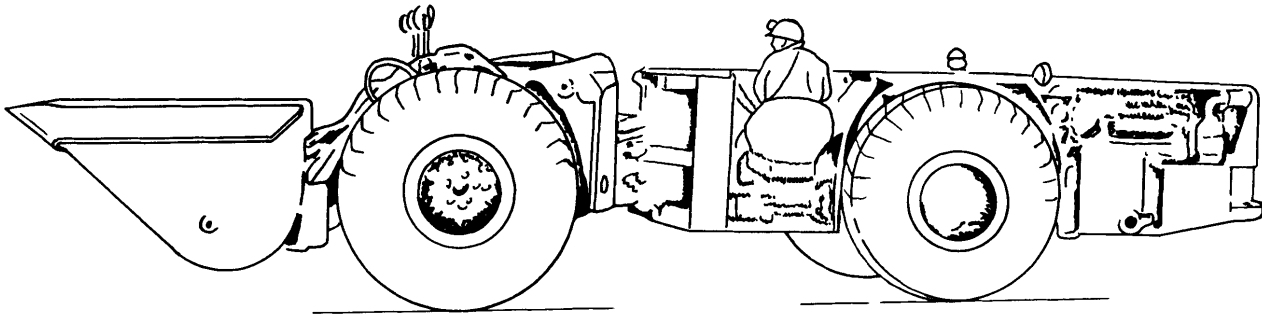

Figure 2-2. Fan-Hole Drill Operation.



WAGNER ST-5A SCOOPTRAM

LOAD — HAUL — DUMP VEHICLE

CAPACITY — 5 CU YDS

WEIGHT — 21 TONS

LENGTH — 29' - 3"

WIDTH — 8' - 01/2"

HEIGHT — 5' - 7-1/4"

ENGINE — DEUTZ, 8 CYLINDER, AIR COOLED DIESEL, 195 HP

Figure 2-3. Load-Haul-Dump Vehicle.

Additional by-products include copper, which is separated from the waste rock, heavy media, and crushed rock.

The surface facilities include an office area, warehouse, machine and repair shop, electric shop, garage, carpenter shop, hoist and compressor house, mine and mill change houses for employees, dispensary, water treatment plant, sewage treatment plant, and a sawmill.

Grace Mine employed approximately 820 persons from Berks County and contiguous counties. (Bethlehem terminated production at Grace Mine during July, 1977, and there are no known plans to resume operation.) Underground production employees totaled approximately 220, working 20 shifts per week to produce an average of 10,000 tons per day of crude ore and development waste. The average working force per shift was 74 employees. Engineering personnel were located at the mine to better plan and control the progress of the mining operation.

The company owns about 6,500 acres at the mine site, and this provides more than enough land to confine all mining operations well within company property lines. Reforestation of company property, the sawmill operation, and a state game refuge are some of the ecological efforts accomplished at Grace Mine. Other efforts include noise abatement equipment and air and water pollution facilities.

3.0 STATEMENT OF THE PROBLEM

A discussion of the communications and monitoring problems at the Grace Iron Ore Mine can best be accomplished by describing the various subsystems as they existed at the beginning of the Engineering and Administrative Services Contract effort in 1973. These subsystems are described in the following paragraphs.

3.1 Telephone Network

Bethlehem Mines Corporation owned and operated its own pabx telephone system at the Grace Iron Ore Mine. The system consisted of 12 private lines dedicated to underground use. There were 21 telephones located throughout the underground complex, providing 2-way voice communications to strategic locations. The system had been expanded to include several more underground lines and telephones. Surface phones were standard desk-top type dial units. The underground phone sets, manufactured by Northern Electric, were in ruggedized environmental cases. Direct dialing via a company phone directory was used, and the local company operator did not do any personnel location. The system incorporated such features as call forward conferencing and answer from any station, as well as local and long-distance calling capability. All features were not extended to underground phones, however, as mine management felt that these phone privileges would be abused.

The primary drawback to this system was that the telephones were stationary. Several complaints were heard from mine management that underground supervisory personnel were usually not in areas with telephone service. To verify this complaint, a tape recorder was attached to two underground telephones. These telephones were expected to have the most traffic and were nearest to supervisors. As expected, the message retrieved from the tape recorder indicated that most calls were for unlocatable supervisory personnel. The telephones were also unanswered on many occasions. The need for a paging system as an extension of the telephone system was evident.

3.2 Vehicular Communications

Prior to the changeover on the sixth production level to rubber-tired diesel vehicles, trolley-operated locomotives were used for haulage on the upper levels. A low-frequency (1f) carrier phone radio installed on each locomotive permitted any locomotive operator to talk to any other operator via the trolley interconnect. An attempt was made to continue the use of 1f carrier radios on the sixth level. Since the trolley was no longer available for signal transmission, an 8-foot loop antenna was installed on the hood of each vehicle.

A base station transmitter-receiver (transceiver) was connected between a rock-bolt ground and a 2,000-foot length of No. 12 AWG wire. The far end of the wire was also grounded to rock-bolt anchors. Thus, a loop with a 4,000-foot effective length was provided. The wire was suspended from the haulageway roof using T-bars anchored into the rock. The T-bars were located approximately every 20 feet. This antenna propagated signals throughout the sixth level of the mine as well as to equipment still operating on the upper levels. However, the 8-foot antenna size required on the vehicle proved to be too large and unwieldy and prevented easy vehicle servicing. Also in view of future expansion plans, a better means of vehicular communications was needed.

3.3 Fan-Hole Drill Operator

The fan-hole drill operators, working alone in remote areas of the mine, were in need of a communications link with a check-in station. A routine check-in at half-hour intervals was established to ensure the operation of each operator's communications equipment and to

provide a means by which he could immediately summon help. For this application, battery-powered 20-watt FM carrier phones (operating between 65 and 130 kHz) were coupled to a temporary phone line and strung to the nearest permanent phone line. An rf coupler was used to interconnect the temporary phone line to the permanent phone line.

A base station, connected to the permanent phone line and monitored by the conveyor operator, completed the communications link to the fan-hole drill operator. This system had many problems. The fan-hole drill operator's equipment, being bulky, was located some distance from him and was not immediately accessible in case of an accident. The system, being hard-wired, required wire maintenance and splicing to extend the system as the work areas progressed. Interference problems existed between the system and the shaft B hoist communications system because of undesired signal coupling, poor receiver selectivity, and high transmitter harmonic output.

This system was considered by the mine to be temporary, and a more suitable method of communicating with the fan-hole drill operator was needed.

3.4 Hoist Communications

The hoist communications systems, as well as the lf carrier systems, were plagued with several problems. To conduct the signals down the 2,800-foot shafts, antenna wires had to be strung down the shafts and terminated at the bottom. The antennas were fed from the top by the hoist transceivers. Antennas were also located on top of the cages in close proximity to the shaft antennas. All antennas required frequent maintenance because they were subject to damage from material being hoisted in or accidentally falling down the shaft. Several areas of low signal strength prevented continuous communication in the shafts. Also, as previously mentioned, there was interference between the hoist communications system in shaft B and the fan-hole drill operator's system. This interference posed a safety problem and could be tolerated only until a better communications system could be devised.

3.5 Emergency Warning System

The mine's compressed air system was used in a conventional stench warning system to notify all underground personnel of an emergency situation. Methyl mercaptan ("rotten cabbage" smell) or some other distinguishable odor was introduced into the compressed air system at the surface when an emergency was detected.

It took approximately 30 to 45 minutes for the stench to reach all areas of the mine complex. A preplanned course of action was taken by everyone underground when the stench was detected; all personnel were to report to designated rescue chambers. The rescue chambers were structurally reinforced areas (within the mine) equipped with first-aid and emergency equipment. These chambers were designed to protect the men during roof fall or other mine emergency situations. The chambers were also provided with telephone links to the surface pabx.

Because the rescue chambers were vulnerable to damage of pabx wire links to the surface, a more reliable rescue chamber communications system was needed.

3.6 Fan Monitoring

Operation of the two main ventilation fans, which used shaft B as the air intake source and were located underground on the sixth level, was monitored on a go/no-go basis. Alarm information was supplied to the guardhouse on the surface via a dedicated hard-wired pair. The guard on duty would take appropriate action as dictated by company policy if one or both

fans were not in operation. It was felt that the system could be improved by monitoring analog airflow at various locations underground to ensure that the fans were operating properly, not just on or off.

3.7 Mine Drainage Monitoring

This monitoring system combined a high-water-level alarm in the shaft B sump and the power-off indication for the main underground pumps. The alarm information was supplied to the guardhouse and hoist house via a dedicated hard-wired pair. Personnel on duty would take appropriate action as set by company policy if an alarm situation occurred.

3.8 Underground Environmental Monitoring

Portable hand-carried monitoring equipment was used to make weekly checks of the various parameters in all working areas. Parameters measured included airflow, carbon monoxide (CO), nitrogen dioxide (NO₂), and dust. The mining engineer in charge of these measurements required one and one-half days per week to complete the measurements. Ventilation control required a balance between adequate airflow for diesel exhaust dilution, shot-fire combustion products, etc, and minimization of airborne dust. The time between measurements and the time required to perform the measurements necessitated a faster, less time-consuming measurement method.

3.9 Summary

These problems can be summarized as follows:

- a. Telephone Network
 1. Fixed location only, not allowing for movement of supervisory personnel during normal daily activities.
- b. Vehicle Communications
 1. Large cumbersome antennas on vehicles reduced the lf carrier system to being unusable.
 2. Without the lf carrier system, the mine was left with no communications on vehicles, increasing vehicle safety problems and leaving mine personnel with no way of knowing vehicle locations.
- c. Fan-Hole Drill Operator
 1. Interference between fan-hole drill operator communications and the shaft B lf carrier system presented safety problems.
 2. Large bulky radios were located too far from the drill operator to do him any good in the event of a crippling accident.
 3. Vulnerability of, and required maintenance to, the temporary wire phone line reduced reliability.
- d. Hoist Communications
 1. Encountered same interference problem as identified under fan-hole drill operator (above).
 2. Large amount of maintenance required on shaft wire antennas and cage antennas.
 3. Low signal strength prevented continuous communication in the shafts.

- e. Emergency Warning System
 - 1. Slow response of warning system.
 - 2. Vulnerability of rescue chamber communications.
- f. Fan Monitoring
 - 1. Insufficient information provided by fan monitors.
- g. Mine Drainage Monitoring
 - 1. Insufficient information provided by drainage monitors.
- h. Underground Environmental Monitoring
 - 1. Too long between measurements to be effective in emergencies.
 - 2. Time required to perform measurements was too long.

4.0 PLANNED SOLUTION

Adequate communication within a mine and to the surface is a vital part of the proper operation of an underground facility. This communication capability is not only an important factor in the concept of safety precautions, but it is also an aid to the day-to-day operations.

In a like manner, a judicious choice of monitored parameters of the underground environment and selected machinery will yield a cost savings in production and will also augment safety. Many man-hours and material dollars can be saved by knowledge of conditions before they become problems. Situations that could be disastrous can be predicted and proper solutions implemented before a problem occurs. Proper environmental and machine monitoring is the key to safer, more productive underground mining.

4.1 Contract Brief

The problems associated with the communications and monitoring systems (or lack thereof) in Grace Mine were described in paragraph 3.0, Statement of the Problem. Solutions, as devised under provisions of the USBM Engineering and Administrative Services Contract SO133035 and JO377076, were implemented in accordance with the following program:

4.1.1 Phase 1 -- Communications Survey

- a. Determine the communications and monitoring requirements for the mine in conjunction with the USBM Technical Project Officer (TPO) via site surveys and personnel interviews.
- b. Provide an itemized list of the communications and monitoring requirements, and submit this list to the USBM TPO.

4.1.2 Phase 2 -- Whole Mine Communications/Monitoring Systems

- a. Prepare drawings showing equipment selection, location, and installation details, and submit same to the TPO.
- b. Prepare a final technical report on the recommended system solutions to the approved list of communications and monitoring requirements.
- c. Prepare system block diagrams and lists of materials for installation at the mine.
- d. Review equipment locations and installation details with mine personnel.
- e. Coordinate USBM purchase of all recommended equipment.

4.1.3 Phase 3 -- Preparation of Equipment Procurement

- a. Write specifications on individual equipments and subsystems to serve as procurement documents.
- b. Prepare procurement lists, and submit same to the TPO.
- c. Assist USBM in procuring recommended equipment.

4.1.4 Phase 4 -- Equipment Acceptance

- a. Prepare "Inspection Checklist" to serve as a guide for receiving equipment and components purchased.
- b. Perform incoming inspection on all equipment as it arrives at Rockwell-Collins, Cedar Rapids, Iowa.

- c. Prepare "Calibration and Test Checklist," using specifications and manufacturer's information.
- d. Perform initial electrical tests on equipment as it is received, documenting the results.
- e. Assemble subsystems.
- f. Calibrate and align all equipment.
- g. Review test reports for inclusion in a permanent logbook record.
- h. Perform final systems integration tests to ensure that all subsystems have been interconnected correctly.
- i. Demonstrate final system tests to the USBM TPO at Rockwell-Collins Cedar Rapids, Iowa, test facilities.

4.1.5 Phase 5 -- Systems Installation

- a. Review installation plans with mine and USBM personnel.
- b. Ship all subsystems to the mine.
- c. Assist the mine in installing systems.

4.1.6 Phase 6 -- Maintenance Training Program

- a. Prepare operations and maintenance training program for mine personnel.
- b. Conduct sessions at the mine on minor repair and routine maintenance of all equipment installed.
- c. Coordinate the attendance of mine technicians at manufacturer's schools.
- d. Review system operation and maintenance problems, recommending corrective action.

4.1.7 Phase 7 -- Systems Operability

- a. Prepare systems logbook to be used by mine personnel for recording systems maintenance performed.
- b. Identify test points for the systems in a manner and format consistent with the logbook.
- c. Determine acceptable test limits and methods for routine maintenance of equipment.
- d. Prepare test plan and coordinated schedule for a systems operation demonstration.
- e. Perform "called-for" acceptance tests, and demonstrate system to USBM and mine personnel.

4.1.8 Phase 8 -- Field Support and Modification

- a. Provide follow-on support, as required, to modify and maintain the systems after acceptance of the installation.
- b. Document modifications performed and periodic systems tests.

4.2 Survey Results

The communications and monitoring survey results at Grace Mine indicated a need for new or improved communications and monitoring capability in the following areas:

- a. Shaft hoist communications.
- b. Dispatch/communications for underground vehicles (ambulance).
- c. Communications for fan-hole drill operators.
- d. A paging or call alert for supervisory personnel.
- e. An independent communications system for refuge chambers.
- f. Machine-mounted carbon monoxide (CO) and nitrogen dioxide (NO₂) monitors on diesel-powered vehicles (local indication only).

- g. Air quality monitoring (airflow, CO, NO₂, and temperature) at the major fresh air and return air junctions (data to be remotely displayed at the surface via a telemetry system, which ideally would operate on the existing telephone system on a noninterfering basis).
- h. An improved mine drainage pump monitoring system.
- i. An improved fan monitoring system.

4.3 Proposed Solutions

4.3.1 Shaft Hoist Communications

To improve the shaft B hoist phone communications system, a dual-frequency diversity hoist radio system was proposed (figure 4-1). This system was to use inductive coupling to the cage cable and to provide the following performance characteristics:

- a. Dual-frequency system (35 and 52 kHz) for null minimization.
- b. Transmit spurious and harmonic content a minimum of -60 db, relative to the carrier level.
- c. Receive sensitivity of 10 μ v for 20-db quieting.
- d. Receiver rejection at frequencies of 88, 100, 115, and 145 kHz, 80 db, relative to the desired carrier frequency sensitivity of 10 μ v.
- e. Receive spurious emission and image rejection of -60 db.
- f. Crystal frequency control with stability of ± 0.25 percent of the assigned center frequency.

This equipment was developed on USBM Contract HO230034.

4.3.2 Dispatching and Communication for the Underground Ambulance

The underground ambulance communication requirement for improved health and safety considerations was found to be met best by combining it with a wireless haulage communications system. This approach would allow in-motion communication, with a central dispatcher and other radio-equipped vehicles or individuals, after the initial telephone dispatch of the ambulance from the vehicle repair area.

4.3.3 Communication With Fan-Hole Drill Operators

The previous system (described in paragraph 3.0) was considered inadequate because of interference problems with the shaft B hoist communications system, vulnerability of the extended cable to damage, and lack of portability when the drill operator changed locations.

The drill operator communications requirement that was, again, basically for improved health and safety considerations was also one that was best covered by incorporation into the wireless haulage communications system. This approach would provide the required functions in an integrated system, solving the problems with the carrier system previously mentioned.

4.3.4 Paging or Call Alert of Supervisory Personnel

As discussed in paragraph 3.0, a need existed for some form of paging system. A basic system utilizing 1-way call alert techniques with the existing telephone system, similar to that planned for coal mine telephone systems, was presented to mine management. Objections were raised by management in the area of interruptions to, and possible agitation of, supervisors.

Further discussions resulted in selection of 2-way radio paging to selected supervisory personnel as a desirable system for installation. This approach allowed integration of the paging function into the wireless haulage communications system.

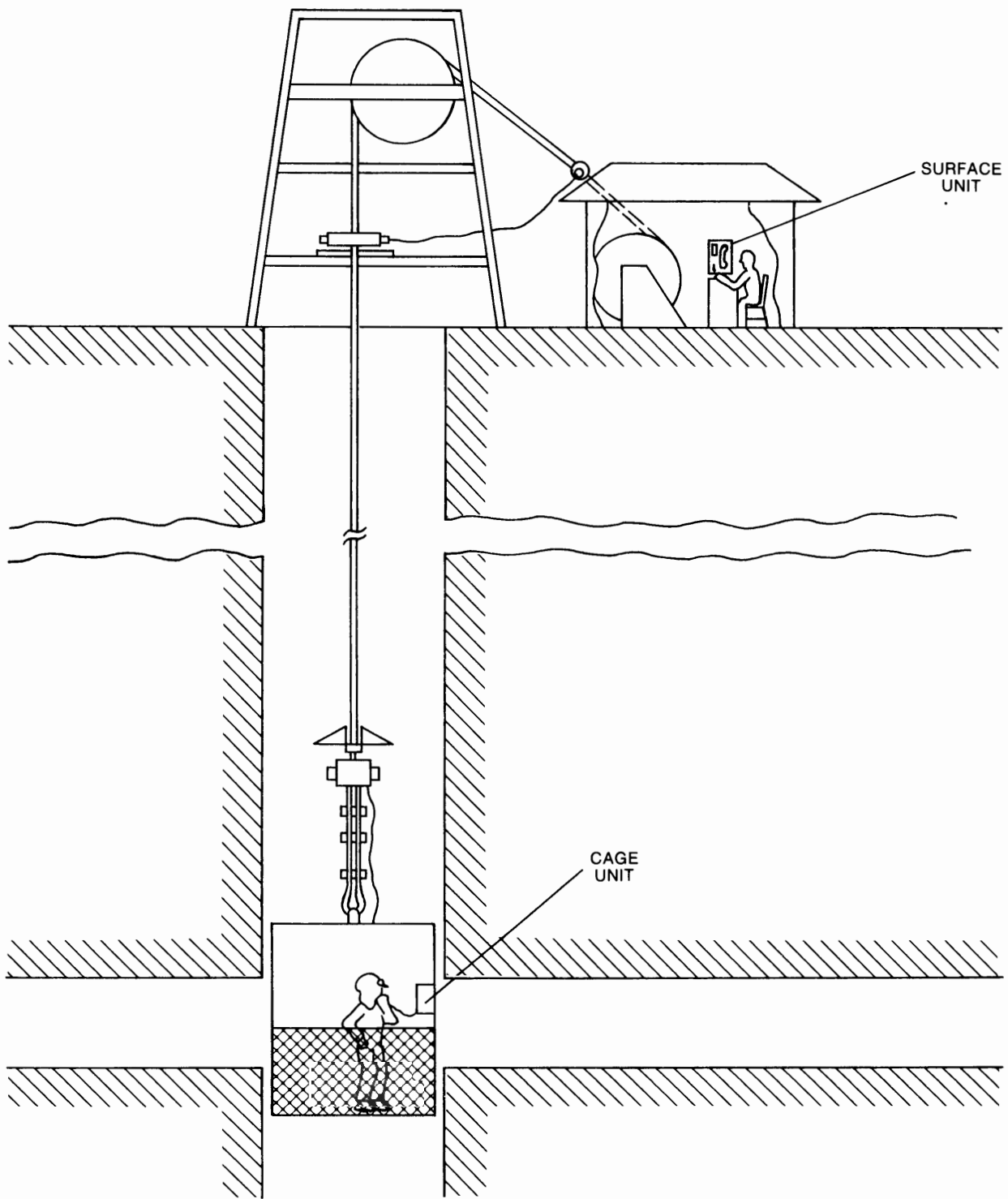

Figure 4-1. Hoist Communications System.

4.3.5 Refuge Chamber Communications System

The emergency communication requirement was for a system that would provide a 2-way link from the underground refuge chamber locations (crusher room and tool room) to the surface. Through-the-earth, low-frequency, electromagnetic techniques, as utilized for trapped miner location in coal mine applications, seemed worthy of consideration (with suitable modifications for this communication requirement).

Consideration was given to the increased overburden depth and increased conductivity of Grace Mine in comparison with more-shallow, less-conductive typical eastern coal mines. USBM up-link propagation experiments performed at Grace Mine indicated detectable surface signals from a moderate transmitting moment when the transmitter source was not located under the orebody. Further experiments using similar frequencies and transmitting moments with the source located under the orebody did not produce satisfactory results with respect to vertical range.

Since intrinsic safety limitations were not applicable to the Grace Mine situation, consideration was given to using increased transmitting moments, within practical limitations, in the mine. It was pointed out that possible vertical range improvements would still require the use of a narrow-band signaling system such as on-off keying and almost certainly would not provide capability for a down-link voice channel.

Both the use of twisted-pair wires and microwave through a bore-hole were also investigated and eliminated as possible solutions for the rescue chamber communications. These two carrier methods were eliminated because the realignment of bore-holes that occurs during a rock shift would shear the twisted wires or cut off the microwave link.

In view of the further experimentation and hardware development required to obtain proven system components, the implementation of a refuge chamber communications system at Grace Mine was deleted from the proposed communications improvements.

4.3.6 Wireless Haulage Communications System

As previously discussed, the communication requirements of paragraph 4.3.2 through 4.3.4 can be fulfilled by one integrated haulage communications system. The operational requirements make it highly desirable that this be a wireless system. The If carrier system previously used had worked and would have remained in operation had it not been for the cumbersome antennas employed on each vehicle. A search was initiated for a system that could replace the If carrier system as a vehicular/dispatch communications system and additionally provide the capability for personnel paging and dispatch (supervisory and fan-hole drill operators). Investigation by the USBM and Rockwell-Collins revealed that If carrier systems generally employ twisted wire (or other solid conductors) for transmission. If systems that do not employ twisted wire require rather large loop antennas to generate sufficient signal strength for acceptable transmission distances. Off-the-shelf or readily modifiable equipment did not exist and would have required several years and many dollars to develop. The technology required to reduce antenna size and package units for vehicular and personnel usage did not exist.

Research thereby turned to recent developments being made with communications in railroad and subway tunnels. Experiments in United States and European railroad tunnels had shown successful results using various propagation methods at high, very high, and ultrahigh frequency ranges. Consideration was therefore given to the following three European "leaky-feeder" cable communications systems.

- a. INIEX/Delogne system that employs regularly spaced radiating devices along conventional flexible coaxial cable. (Belgium)

Experimental and theoretical investigation of this system had been performed including tests at the USBM Bruceeton Safety Research Mine. The optimum operational frequency was believed to fall in the frequency range of 2 to 20 MHz. Several uncertainties regarding performance in typical US mine environments still had to be resolved. These uncertainties were connected in particular with the restraint that in United States mines the cable would have to be installed close to the roof or rib with consequent increases in attenuation (in contrast to the more central location in the arched galleries in Europe) and with the influence of dirt and water on the cable and radiating devices.

- b. Coaxial cable with high surface transfer impedance, specially designed "leaky" braid outer conductor. (France)

Theoretical investigations carried out at the University of Lille in France indicated that effective communications along several miles of mine haulageway could be accomplished by use of a coaxial cable whose braided outer conductor was designed and constructed for "optimum" leakage of radiation. The optimum operational frequency was believed to fall in the frequency range of 5 to 10 MHz.

Similar uncertainties existed with regard to the effects of dirt, water, and proximity to walls of the mine tunnel on the performance of the proposed French scheme in US mine environments, as mentioned in the discussion of the Belgian cable system.

- c. Radiating coaxial cable with repeaters. (United Kingdom)

Experimental and theoretical investigations into the various "leaky-feeder" systems have been in progress since 1966. The direction of the various investigations has been toward the extension of the basic linear range of the system by the use of additional fixed base stations to increase the total coverage, as required, or the insertion of small repeaters or amplifiers in the transmission line to compensate for accumulated losses.

A version of the system (the "daisy chain" system) uses broadband 1-way repeaters to simultaneously amplify both the high-level transmit signal and the lower-level signals received in the cable from the mobile transmitter. The cable receiver is located at the end of the cable, with the received audio supplied to the transmitter at the other end of the cable via an audio pair. This system provides duplex communication capability with transmit and received rf signals flowing in one direction on the cable and avoids costly isolators. This type of scheme is attractive mainly for systems requiring a single path of communications with no "branch" lines such as railway tunnels.

Typical uncertainties expected in the performance of this system type involved the reliability and maintainability of the repeaters in a mine environment, as well as the lateral communications distance from the cable.

Measurements at ultrahigh frequencies indicate the following significant wireless propagation characteristics: (1) Attenuation (in decibels) increases linearly with increasing distance; (2) horizontal polarization produces significantly lower transmission losses; and (3) losses decrease significantly at a given distance as the frequency is increased from 200 to 1000 MHz.

After site surveys and interviews with mine personnel, it was determined that 11,000 feet of "leaky-feeder" cable would be required to fully implement the mine with the communication system. This represented the mine's requirements for the two years following initial site surveys conducted in the spring of 1974. Surveys conducted after system installation indicated that the 11,000 feet would serve the mine's communication needs until 1980. When the mine closed in July 1977 all the cable had not yet been used.

To satisfy the communication functions and expansion requirements, various hardware configurations involving use of multiple base stations and repeaters were examined. This examination resulted in a scheme using linked uhf zones. System size requirements was a factor in selection of the two-zone system with each zone containing a vhf/uhf repeater station. To obtain the best lateral communication range, a uhf operating frequency of 450 MHz was chosen.

In addition to the normal mobile or portable to/from communications with the dispatcher, a requirement existed for vehicle and portable-to-portable communications. Safety considerations dictated the use of a single-channel communications system, particularly with suspect vehicular traffic.

Two applications of the linked uhf zones were considered, one using 1/2-inch "leaky-feeder" cable and the second using 7/8-inch "leaky-feeder" cable. The 1/2-inch and 7/8-inch cables were readily available as off-the-shelf items. Figure 4-2 is a block diagram of the "leaky-feeder" communication system at the Grace Mine. Paragraph 9.0 (RF "Leaky-Feeder" Communications System Design) is a description of the analysis undertaken to choose between the two cable sizes, with recommendations. A detailed step-by-step design of the system using vhf frequencies to link the two uhf zones is also included.

The selected portable and mobile equipment uses separate transmit and receive frequencies, providing simplex single-channel capability. The repeater station in one zone transmits and receives uhf signals in that zone and relays the signal using vhf frequency to the repeater in the second zone. The second repeater converts the vhf signal and retransmits it using uhf in the second zone. The vhf link for the uhf zones was chosen for the following reasons:

- a. The coaxial cable is more rugged than a wired pair and would provide a more reliable link between repeater stations.
- b. To demonstrate maximum equipment capability to the mining industry.
- c. To increase reliability during possible cable breaks between the two repeater stations. It was felt that the rf link could be maintained even during cable breaks.
- d. The use of vhf frequencies for the link rather than uhf simplifies the filtering and isolation requirements at each repeater station.

The initial system installation at Grace Mine included the following complement of equipment:

- a. Approximately 11,000 feet of 7/8-inch "leaky-feeder" line.
- b. One base station (to be located at the 4U skip console).
- c. Two uhf/vhf repeater stations.
- d. Eight vehicular transceivers.
- e. Six portable transceivers for fan-hole drill operators.

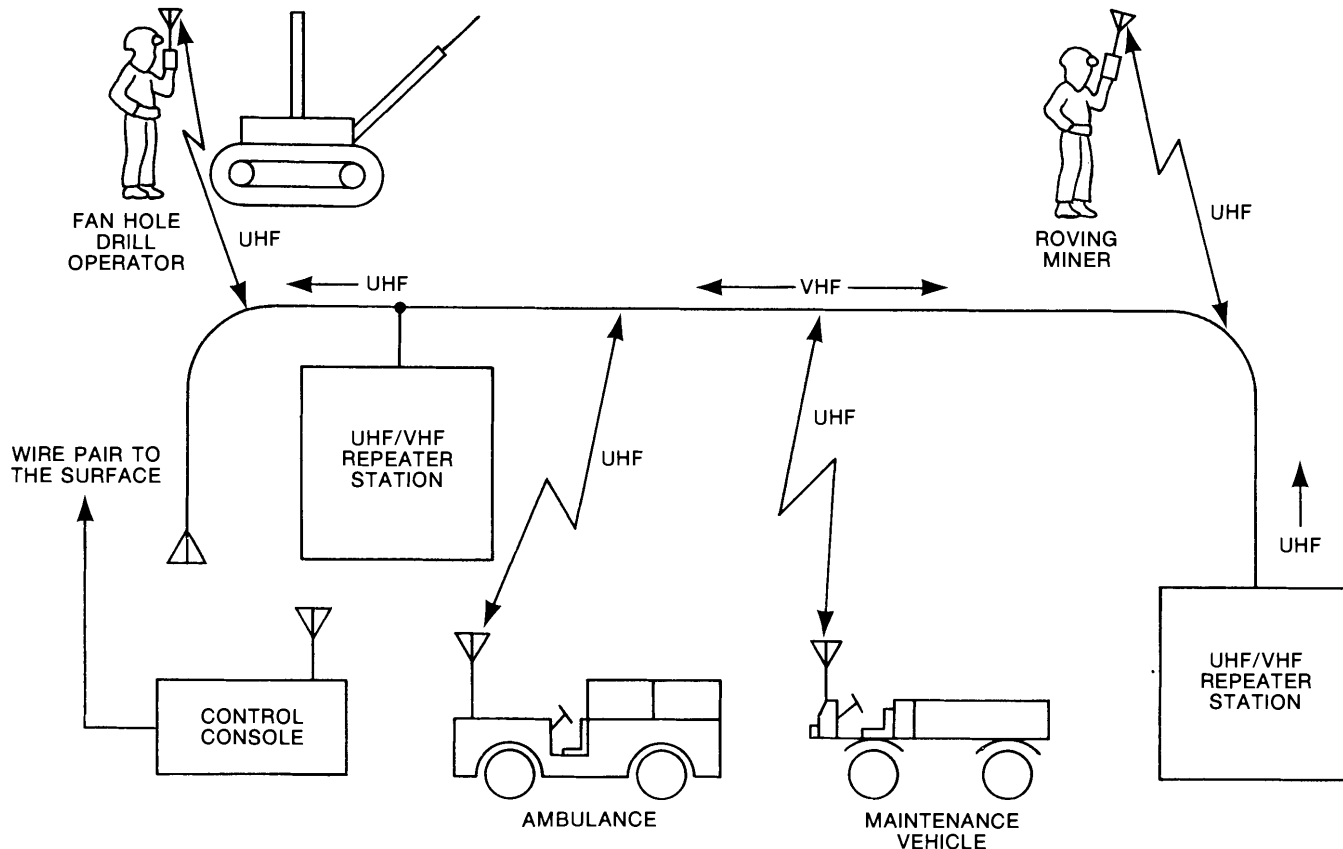

Figure 4-2. RF "Leaky-Feeder" Communications System.

- f. Four portable transceivers for roving miner voice paging.
- g. Surface access via dedicated audio lines to the underground system.
- h. A communications center.

4.3.7 New Monitoring Systems To Be Installed

The contract requirement for off-the-shelf hardware items and certain USBM budget limitations caused modifications in the monitoring system approach. Monitoring and telemetry equipment being procured on other USBM programs would be utilized in the Grace Mine monitoring system. The following system functions were proposed:

4.3.7.1 Vehicle Monitoring

A quantity of nitrogen dioxide (NO₂) and carbon monoxide (CO) sensors would be procured and modified for environmental protection and required mounting configuration. These would be placed on selected vehicles for local indication to the vehicle operator of NO₂ and CO levels.

4.3.7.2 Air Quality Monitoring and Telemetry System

The remote monitoring system would provide real-time indications of analog values of selected parameters (airflow, CO, NO₂, and temperature) as well as threshold alarm indications at the telemetry master station. Since no data storage or data processing would be

provided (other than latching of alarm indications), the usefulness of the analog parameter data would depend upon the establishment of manual logging procedures to accumulate data trends that would allow correlation with the existing manual weekly monitoring results.

The initial remote monitoring system installation at Grace Mine would include the following complement of equipment:

- a. Digital telemetry system including:
 1. One master station.
 2. Four remote units (each with eight separate analog data inputs).
- b. Sensor/transducer units
 1. CO, NO₂, temperature, and airflow sensors from various manufacturers.

The digital telemetry and monitoring system would provide air quality monitoring at four remote locations. Transducer units to monitor carbon monoxide, nitrogen dioxide, temperature, and airflow were provided. At three of the remote locations, three different types of NO₂ sensor units were installed and evaluated. These units were suitably repackaged for use in the high-humidity, dusty mine environment.

The telemetry system, as implemented, uses frequency multiplex techniques to allow digital data transfer from a number of remote stations to the master control and display station. A two-wire voice grade circuit that carries standard FSK channels with 120-Hz spacing is used to connect the various remote stations with the master station. Each remote station can accommodate eight separate analog data inputs. The remote station logic sequentially samples the analog input to make up a 16-bit digital word that is transmitted on the remote unit FSK channel to the master station. Alarm indication is also included to indicate that an analog value is exceeding a preset reference level on any implemented analog channel. Figure 4-3 is a block diagram of the telemetry system.

Both the remote station units and the master station unit provide display and alarm information concerning the monitored functions. Either automatic or manual stepping may be selected at either the remote units or the master station unit.

Since the effort was begun on the monitoring system, there was close communication between USBM and the various monitor system vendors. Originally, the system was to be forwarded to the contractor (Rockwell-Collins) for environmental testing and analysis; however USBM took the active role in this area because of their experience in this field. Because the objectives of the monitoring effort were somewhat different from those of the basic Grace Mine program, the responsibility of the monitoring systems was assumed by USBM. The installation, performance, and maintenance of such systems will therefore not be discussed further in this report.

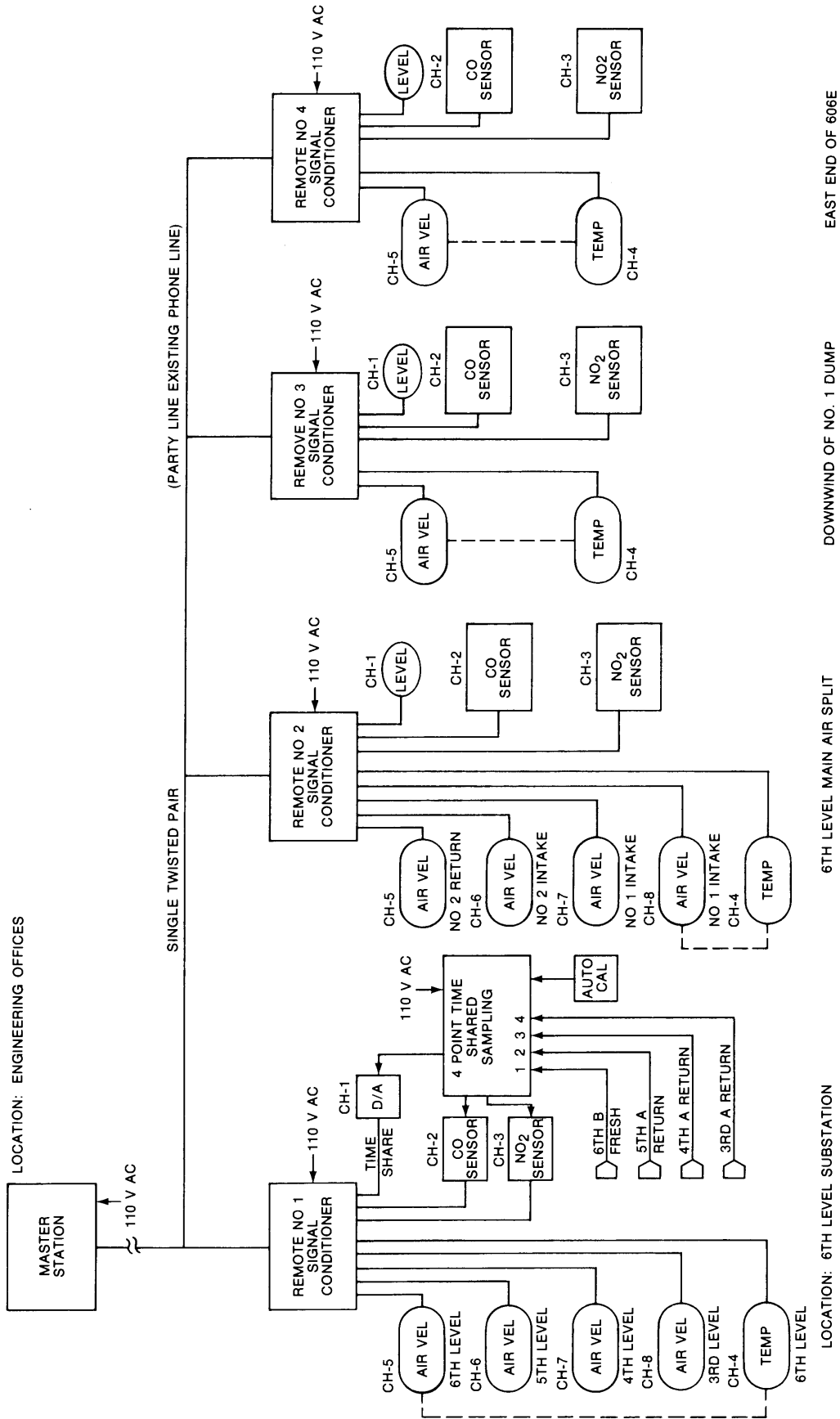

Figure 4-3. Environmental Monitoring System.

5.0 HARDWARE IMPLEMENTATION DESCRIPTION

The objectives of this program were to provide wireless communications between underground personnel with an interconnection to the surface and to provide improved 2-way voice communications between the hoistman and the cageman in shaft B. Underground personnel includes roving miners in production, haulage, and shop areas; fan-hole drill operators working alone; and maintenance vehicles and ambulance operators. The surface interconnect was to be with the guardhouse attendant.

As described in paragraph 4.0, the systems selected to fulfill the communication requirements of Grace Mine are an rf "leaky-feeder" system using commercially available equipment and an inductive hoist communications system developed for the United States Bureau of Mines. The implementation of the hoist system will be discussed first.

5.1 Hoist Communications

An inductive communications system was developed by USBM under Contract HO230034. This communications system was designed to provide reliable voice communications between the hoist operator and the hoist cage at all levels down to 10,000 feet (figure 5-1). Dual-frequency FM transceivers, operating at 35 and 52 kHz, were developed as experimental units. The two signals are simultaneously transmitted via the hoist rope and received by the dual-frequency receiver in which decision circuitry selects the strongest signal. Transmit power is adjustable from 1 to 10 watts. The communications system consists of two sets of transceivers, power supplies, station controls, and ferrite couplers (antennas), with one set used in the cage and the other in the hoist room. The couplers transfer signals to and from the hoist rope.

The initial installation of this system was at Hecla Mining Company's Lucky Friday Mine in Mullan, Idaho. The results of this installation were favorable enough that a second set of equipment was procured for installation at Grace Mine.

5.1.1 Hardware Description

The hoist room station, shown in figure 5-2, consists of a station control, upper left; transceiver, lower left; power supply/charger, including battery, upper right; and the surface (headframe) coupler, lower right. In addition, the hoistman is provided with a boom microphone, a foot-operated push-to-talk switch, and a remote speaker in place of the station control handset.

The station control speaker is normally squelched. When a transmission is received from the cage, the squelch is broken and the cage operator is heard. To respond, the hoist operator steps on the footswitch and talks into the boom microphone.

The battery rests in its holder above the power supply and is charged by the power supply/charger. After reaching full charge, the battery floats across the power supply, under normal operation, ready to provide backup power should the 117 volt ac be lost.

The cage system, shown in figure 5-3, consists of the station control, upper right; the cage coupler, upper left; and the transceiver, lower right; and is mounted on a plate with the battery supply, lower left. In a typical installation, the station control is mounted at a convenient height on a wall inside the cage. The battery and transceiver can be mounted above or below it, on a shelf, also within the cage. The battery must be readily accessible for replacement. The cage coupler is fastened to the hoist rope above the cage with a built-in clamp. The cage system for Grace Mine is modified to include an interrupted tone on the slack rope alarm and a remote speaker. Additionally, the battery pack is replaced with a high-capacity automobile battery, and a second charger is added to increase the time between recharging and to reduce charging time.

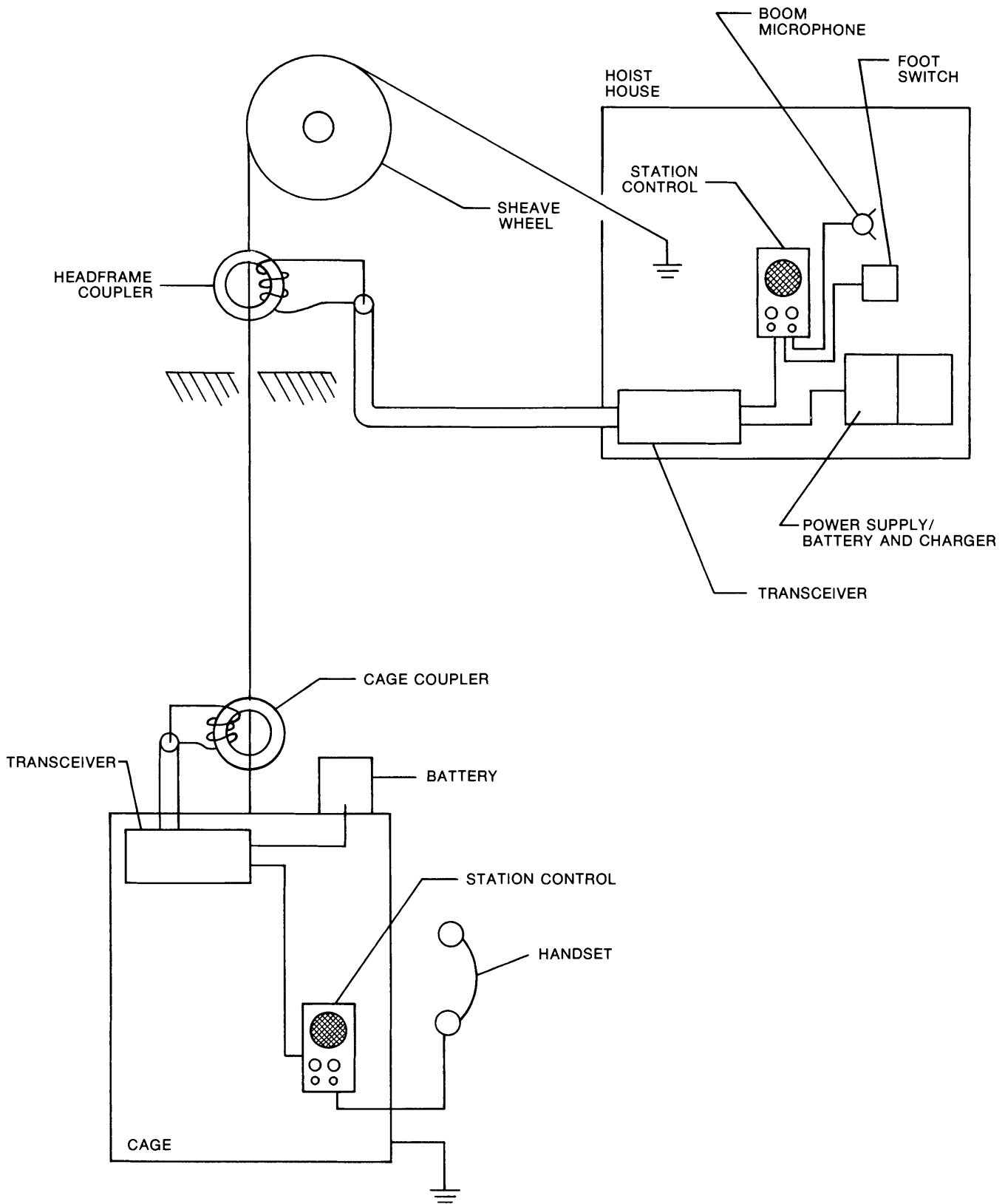

Figure 5-1. Inductive Hoist Communications System.

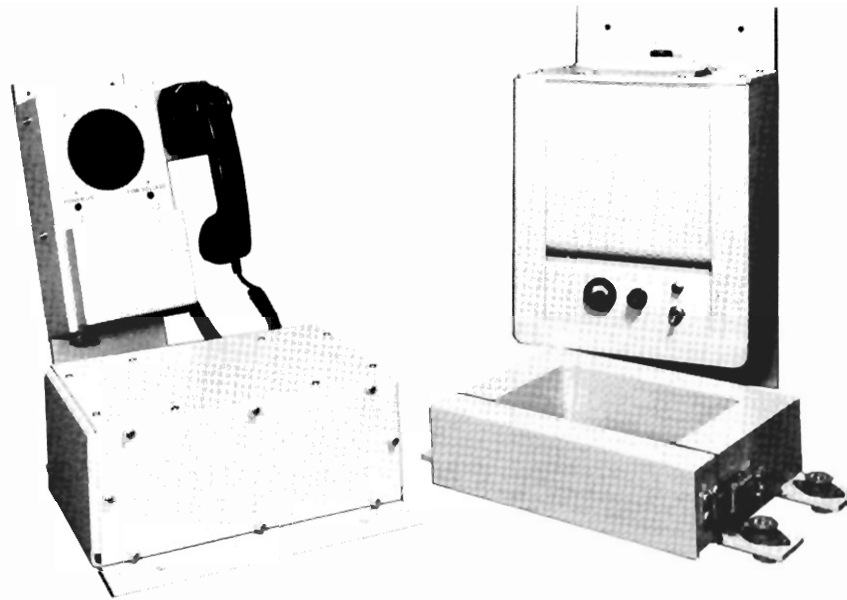

Figure 5-2. Hoist Room Station.

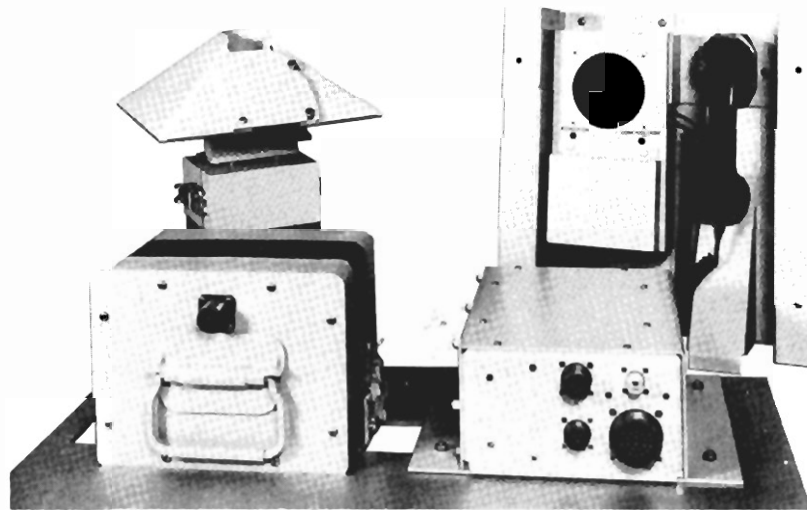

Figure 5-3. Cage System.

The station control in the cage is identical to the one in the hoist room, and operation is similar. With the handset on its hanger, the speaker(s) is activated but squelched. When a transmission is heard, the handset is picked up for 2-way push-to-talk communication.

Refer to paragraph 7.0 for complete equipment specifications.

5.1.2 Installation

The hoist radio, as delivered to Grace Mine, had been thoroughly tested at Rockwell-Collins as a system under provisions of the hoist radio development program, USBM contract HO230034. The system therefore needed no further testing prior to installation in shaft B.

During the summer and early fall of 1974, Grace Mine was preparing to install a new double-deck cage in shaft B. The cage was on the surface being assembled and undergoing safety modifications (figure 5-4). This time period, therefore, was considered to be the most opportune in which to perform the hoist radio installation. With the cage on the surface, the job of installing the cage equipment would be greatly simplified.

A survey trip was made to the mine two months before the actual installation to gather specific details concerning equipment location. Information was acquired to determine requirements for interconnect cable lengths and special mounting adapters. All equipment sites were visited and photographed for future reference. Grace Mine was provided with a list of materials they would have to provide plus a list of anticipated manpower requirements. With the information gathered, necessary interconnect and mounting equipments were built and shipped to the mine, thus facilitating the actual hoist radio installation.

The station control was recessed into the cage wall of the upper deck by cutting an accommodation hole (figure 5-5). The transceiver was mounted on a plate inside the upper cage deck, near the top. All wiring between the station control and the transceiver was enclosed in conduit and mounted on the outside of the cage. A battery box was fabricated and installed on the cage top. A weatherized speaker was installed in the bottom cage deck as a remote extension of the station control speaker. The cage was fitted with a slack rope switch wired into the station control.



Figure 5-4. "B" Shaft Double-Deck Cage Being Assembled on the Surface.

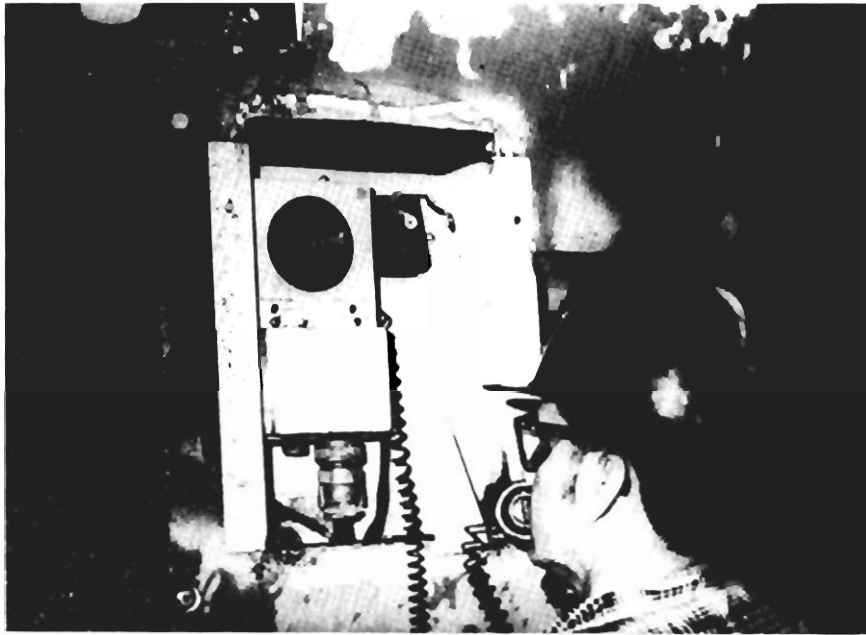

Figure 5-5. Hoist-Shaft Communications Equipment Installed in Man-Cage.

The headframe coupler was mounted on the underside of the shaft B headframe deck, directly below the sheave wheel (figure 5-6). The presence of an enclosure around the sheave wheel required that a mounting bracket be fabricated to suspend the coupler from a bolt flange on the bottom cover.

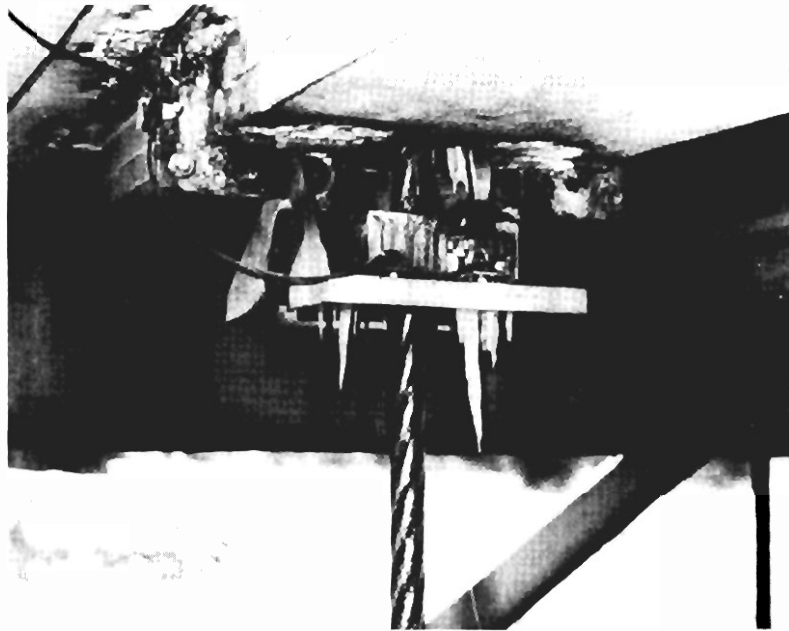

Figure 5-6. Inductive Coupler Mounted Around the Hoist Cable at the Headframe.

The cage coupler (installed when the cage was put into the shaft) was mounted to the hoist rope using a built-in clamp (figure 5-7). Coaxial cable was used to interconnect the coupler and the cage transceiver.



Figure 5-7. Inductive Coupler and Rock Shield Mounted Around the Hoist Cable Above the Man-Cage.

Hoist room equipment was installed with the transceiver and power supply/battery charger combination, attached to a plate, and the plate mounted in the basement beneath the hoistman's console (figure 5-8). The station control was mounted on the front of the hoistman's console to the left of the operator (figure 5-9). A boom (gooseneck) microphone and foot-operated push-to-talk switch were incorporated into the hoist station. The station control and transceiver were interconnected via a premade cable. A remote speaker, located at the shaft top, was also attached to the hoist room station control. A 600-foot length of coaxial cable (located in buried conduit) was used to connect the headframe coupler to the hoist room transceiver.

The installation went well and required only two days to complete. The system "talked" successfully between stations even though the new cage was not yet hung in the shaft. Remote capabilities in the cage were demonstrated, and it was shown that when the slack rope alarm was triggered, emergency transmissions could be made from the hoist room between interrupt tones. When the cage was installed in the shaft, the system was tested again. On a point of utmost importance to the mine, no trace of crosstalk from the fan-hole drill operator's transmissions was discernible on the hoist system. This crosstalk was the major deficiency of their previous hoist radio system and, after a near-fatal accident, voice communications between cage and hoist room had been abandoned altogether in lieu of tone signaling.

All installation was performed by mine personnel, with technical support (where required) from USBM and Rockwell-Collins personnel. The initial operational tests on the system were performed by Rockwell-Collins and USBM personnel, but the final tests (after the cage was installed in the shaft) were performed by mine personnel with no assistance required.

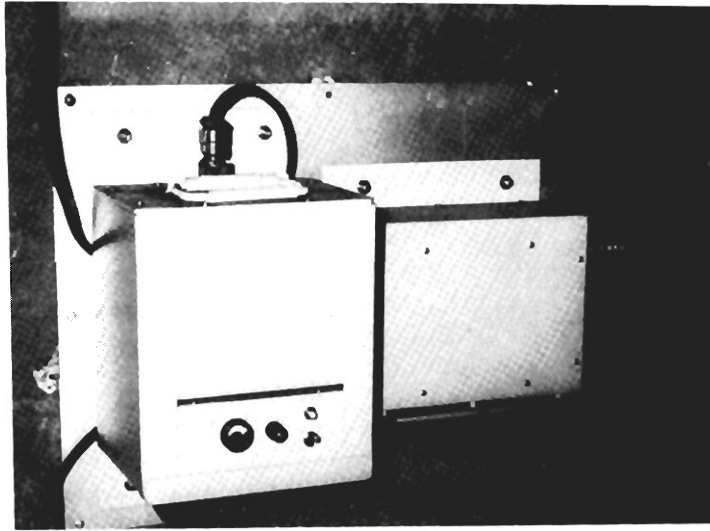

Figure 5-8. Hoist Communications Transceiver With Battery and Charger.



Figure 5-9. Hoist Operator's Equipment.

5.1.3 Follow-On Maintenance and Support

The mine was provided with an operations manual and a supply of spare electronic parts as an aid to system maintenance. Technical support was provided by USBM and Rockwell-Collins personnel when requested, and an electronics technician was hired by the mine to maintain the hoist radio and future communications systems.

Shortly after system installation, Grace Mine requested and received a handset with attached cord to be used as a remote position in the lower cage. There were also complaints that persons on the cage were unable to understand conversations with the hoist operator as a result of excessive background noise.

The boom microphone element was replaced with a noise-cancelling unit, which corrected the problem. In addition, the remote "weatherized" speaker used in the lower cage developed bad fidelity and had to be disconnected. As the unit was never replaced, they relied on the remote handset for lower-cage and cage-top communications.

Several months after system installation, microphone elements on the cage began to fail. The problem was traced to corrosion of the circuitry inside the microphone. These microphone elements were subsequently replaced with standard "carbon-button" units and later with noise-cancelling carbon units. This greatly reduced, but did not eliminate, the problem. The rotation of cage microphone elements became part of a monthly maintenance schedule. Heating of the microphone interior could be expected to help even more.

Other problems associated with the hoist radio system included the following:

- a. Corrosion of the connector contacts on the cable between the cage station control and the transceiver; corrected by periodically spraying all contacts with contact cleaner and by providing the mine with spare connectors and cables.
- b. Hoist room radio breaking squelch when the cage was slowing to 250 feet per minute; problem traced to improper grounding of the headframe coupler.
- c. Hoist room battery pack overheating and failing; corrected by replacing batteries in pack with smaller units that could be cooled more easily.
- d. The switches, connectors, and light-emitting diodes (LED's) associated with the cage station control unit had to be replaced within one and one-half years after installation because of moisture-related failures.

In addition, following the completion of evaluation of the identical hoist radio system at Hecla's Lucky Friday Mine in Mullan, Idaho, all components of the system were forwarded to Grace Mine to be used as spares. These spares provided complete system exchange capability and strengthened Grace Mine's confidence in the support of the system. The hoist communications system, in service since September 1974, has provided excellent service.

Since installation, several sets of measurements have been performed on the system to verify proper operation. These measurements are included in paragraph 8.0.

5.2 RF "Leaky-Feeder" Communications System

To satisfy the objective of communication between underground personnel and vehicles, a guided wireless communications system utilizing commercially available equipment was selected. Portable "handie-talkies" and mobile transceivers were chosen for personnel and vehicles

respectively. The "leaky-feeder" cable, a special type of cable that allows for leakage of signals out of and into itself, was installed throughout the major areas of the mine. Since it was expected that the total cable length would exceed 2 miles, the installation of two repeater stations was planned (refer to paragraph 9.0, RF "Leaky-Feeder" Communications System Design). Although the proposed system would not require a dispatcher or an operator, a communications center was established at an underground crusher room. Personnel could be selectively paged from the center, and an alarm could be activated from either the center or alternate monitor stations at both the shaft bottom and shop area. Surface access to the system would be provided by wiring the shaft bottom monitor station to a surface remote control unit. During a power failure, the system can operate for a period of 24 hours on backup battery power. An engineering design objective was to employ off-the-shelf, readily available communications equipment and installation hardware. In addition, the system chosen was to be compatible with the installation and maintenance capabilities of mine maintenance personnel and was to demonstrate maximum equipment capability.

Through a cooperative agreement between Bethlehem Mines Corporation and the United States Bureau of Mines, and under provisions of USBM Contract SO133035, the aforementioned communications system was developed. Under provisions of USBM Contract SO133035, Collins Commercial Telecommunications Division, Rockwell International, provided the technical expertise to design, package, and test the system at its Cedar Rapids, Iowa, manufacturing facility.

The repeater stations were prewired and the system was assembled for several months of burn-in and testing. This procedure provided for the detection of bad components and helped to eliminate the frustrations of troubleshooting and testing the system underground.

5.2.1 System Operation

The mine is divided into two rf regions, each region (zone) containing one uhf/vhf repeater station and associated runs of "leaky-feeder" (figure 5-10). The system of cables effectively wires the mine for uhf signals between portable and mobile units. Each repeater station can

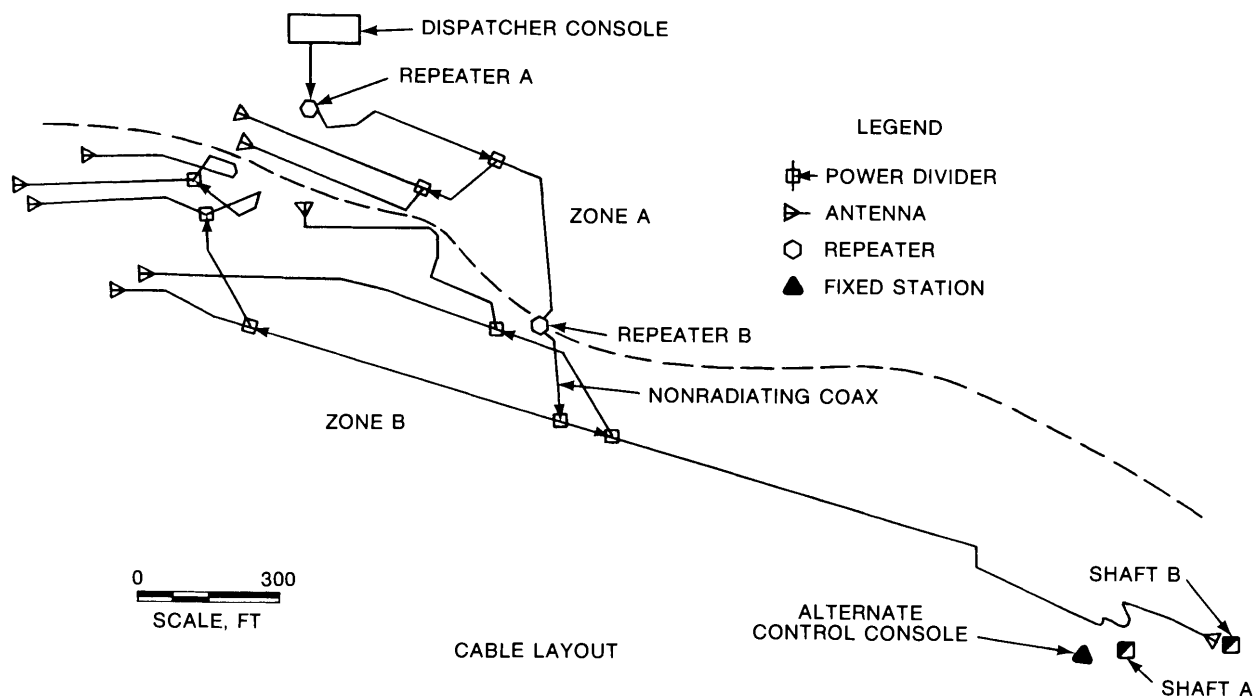

Figure 5-10. "Leaky-Feeder" Cable Runs.

receive and transmit signals on the cable at both uhf and vhf. Vhf signals are used on the cable as a communication link between the stations, while uhf is used for the communication link to and from the portable and mobile units. The two uhf repeaters transmit on F2 and receive on F1, as shown in figure 5-11. The vhf repeaters use frequencies F3 and F4 to interconnect the two uhf zones. Information transferred within a uhf/vhf repeater station is via audio paths. Duplexers (labeled with the letter, D, on figure 5-11) are used to isolate the transmitters and receivers of the uhf and vhf repeaters. Thereby a uhf/vhf repeater station can transmit simultaneously on both uhf and vhf, as well as receive on uhf.

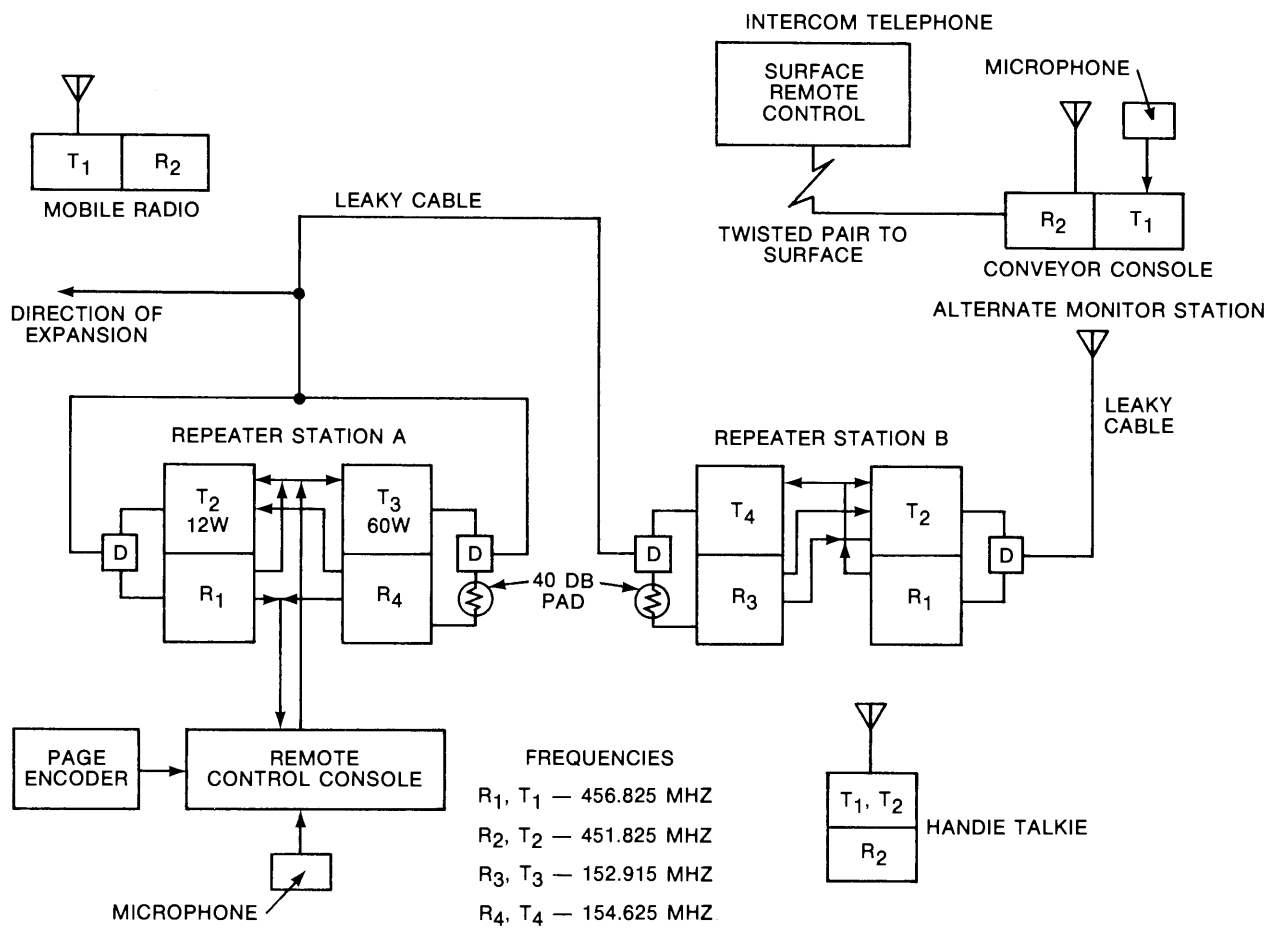

Figure 5-11. UHF/VHF Repeater System.

The mobile radios and the control station radios transmit on F1 and receive on F2. All information therefore goes to the repeaters, then back to all other units. The portable handie-talkies are capable of transmitting either on F1 or F2 and, therefore, are also capable of communication with each other without the repeaters, on a local simplex basis, and accessing all other units by using half-duplex, through the repeaters. Audio control lines are provided from the communications center to repeater station A and from the surface guardhouse to the shaft-bottom station, thus providing system access from two hard-wired locations.

As an example, suppose that someone with a mobile radio in zone A wants to talk to a roving miner equipped with a portable handie-talkie in zone B. The operator of the mobile radio keys his radio and talks into his microphone to transmit his message on uhf F1. The uhf signal is coupled to the "leaky-feeder," travels to uhf/vhf repeater station A, and is routed to the uhf receiver tuned to F1. Within the uhf receiver, the message is converted to an audio signal and routed to the uhf and vhf transmitters. The audio is then converted to uhf and vhf signals and transmitted on F2 and F3 respectively. The duplexers isolate the two transmitters from the receivers, allowing simultaneous reception at F1 and transmission at F2 and F3. Since uhf/vhf repeater station A transmitted the message in zone A on uhf, radios within this zone would receive the message. However, the desired portable is in zone B. Therefore, the signal transmitted on F3 travels on the coaxial cable to uhf/vhf repeater station B where it is picked up by the vhf receiver. The signal is converted to audio and routed to the uhf transmitter for transmission on F2. The uhf signal on F2 is directed back onto the "leaky-feeder" for distribution in zone B; the roving miner in zone B receives the message coupled from the "leaky-feeder" to his portable handie-talkie. Operation of the mobile uhf to repeater, repeater to repeater station vhf, and repeater uhf to portable links requires less than one second to activate. If the roving miner wishes to return a message to the mobile, he repeats the procedure and reverses the path. (The mechanism is automatic, so only he knows that he is talking and listening on his radio.) Communication between the two radios is also received by any other radio that might be listening as well as the communications center, the alternate monitor stations, and the intercom telephone. In this manner, any one radio in the system activates the entire system.

Paging tones can be activated at the communications center via a page encoder. These tones are coupled to repeater station A for transmission on uhf and vhf and are received at repeater station B on vhf for retransmission on uhf. Portable handie-talkies equipped with page-decoding circuitry receive these paging tones and broadcast an audible tone sequence. The portables are equipped with selective decoding and respond to a specific paging tone sequence only. Portables can be equipped with different paging tone sequences to allow for multiple radios with selective paging capability. The communications center may be either manned or unmanned; no operator is necessary for system operation.

An alternate monitor station, located at the shaft bottom, provides an additional access point to the communications network. The monitor station monitors the activity of the fan-hole drill operators and is connected by wire line to an intercom telephone located at the surface guardhouse. The guard can access the system through remote control on the station radio. This feature is especially desirable during maintenance periods when the underground stations are unmanned or during a mine emergency to coordinate evacuation and rescue operations. A second monitor station is located in the shop area but does not have the hard wired link to the surface. This monitor station is used primarily for dispatching the ambulance. All monitor stations are capable of transmitting an "alert" tone that can be used for emergency or evacuation notification.

All components of the system are equipped with emergency battery backup, capable of providing service for 24 hours.

5.2.2 Hardware Description

A "leaky-feeder" cable is a special type of coaxial cable that allows radio-frequency signals to leak into and out of itself. Figure 5-12 shows how the field strength varies in the immediate vicinity of the cable. With the cable as a medium, signals can be transmitted to and received from mobile and portable units in its immediate vicinity; hence, the cable provides a tunnel of signal strength. The signal strength attenuates along a cable run, but repeaters are used to boost signal strength. "Dead-end" lengths of cable are terminated with antennas to extend communication range. Power splitters allow the cable to have side branches.

Three types of "leaky-feeder" cables are used at Grace Mine: 7/8-inch cable with attenuation of 1.2 db/100 ft; 7/8-inch cable with attenuation of 2.9 db/100 ft; and 1/2-inch cable with attenuation of 4.0 db/100 ft. (Note: All attenuations are referenced to the uhf 450-MHz band.) Figure 5-13 shows one version of "leaky-feeder" cable that is used with an attached connector, a power splitter, and a "hard-hat" antenna. The connectors used are specifically made for use with the "leaky-feeder" cable and provide the standard N-type and uhf-type connections.

The repeater stations (figure 5-14), composed of the unique combination of uhf and vhf units, are housed in environmentally protected enclosures. The units require 117 v ac for operation and are equipped with 12-v storage battery backup. The uhf and vhf units are interconnected via hard-wired transmit key and audio interfaces. The uhf units function to receive the low-level signals via the "leaky-feeder" from the vehicle and portable radios and retransmit these signals at a much higher level back out onto the "leaky-feeder." These signals then can be received by radios located several thousand feet away. The vhf units provide control between stations, located about 2,000 feet apart, via the same cable. A 5-MHz separation between uhf transmit and receive frequencies allows connection to the common cable through a duplexer (filter). The vhf frequencies were chosen to avoid third-harmonic interference with the uhf system.

An example of the selected portable equipment is shown in figure 5-15. Two types of portable units were used, those equipped with decoding circuitry for paging purposes and those that were not. Both types of portable radios are capable of direct communications with each other without the repeaters (simplex) or through the repeater link (half-duplex). Notification of a page to so-equipped portables is by sequential tones. The portable handie-talkies are ruggedized, environmentally protected units that are powered by self-contained rechargeable battery packs. The units are belt-mounted with extension microphones, loudspeakers, and push-to-talk switches. Units used by the fan-hole drill operators are equipped with a chest pack harness and accessory noise-reducing "earmuff" and microphone. The receiver audio is then routed to small loudspeakers inside the operator's ear protectors, while the microphone and the push-to-talk switch are installed in a similar "earmuff" that is placed over the operator's mouth when he wishes to make a radio transmission. In some applications where antennas may get damaged,

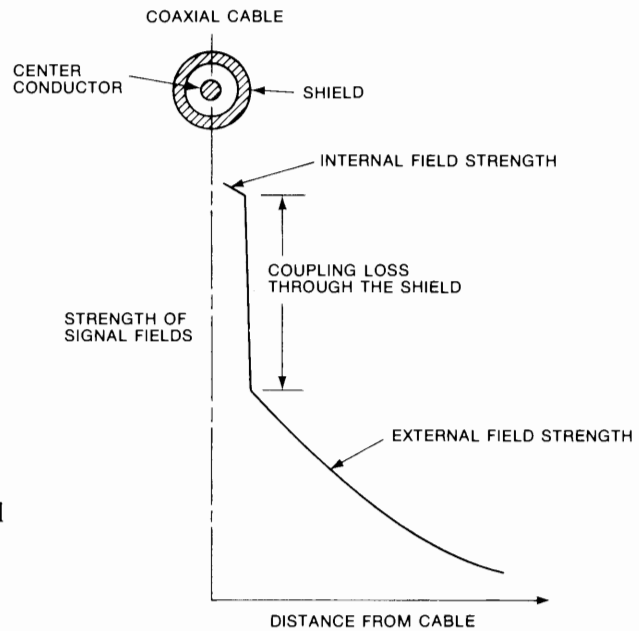

Figure 5-12. Principle of Operation of "Leaky-Feeder".

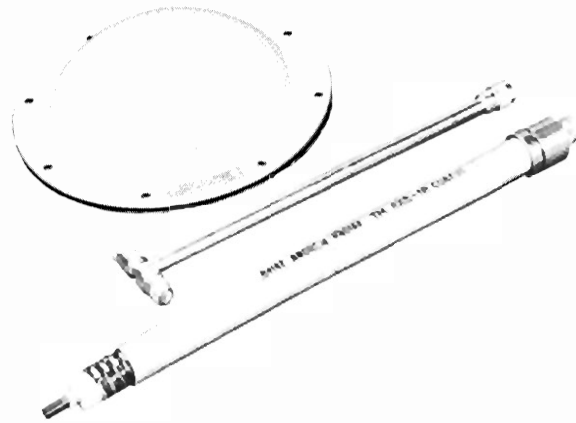

Figure 5-13. Basic Cable Equipment.

the units are equipped with smaller 1/4-wave whip antennas or a small antenna known as a bazooka which, for protection, is enclosed within a section of PVC tubing.

Two types of vehicular (mobile) radios are used. The standard version (figure 5-16) has all controls, microphone plug, and speaker plug located on the transceiver package; this necessitates locating the transceiver within the vehicle operator's reach, which is nearly impossible on mining vehicles. A better radio for this application is the motorcycle version (not shown) with all controls and the microphone plug located on the small loudspeaker enclosure. The loudspeaker can be mounted in a convenient location, with the larger transceiver unit mounted in a more protected area. The antennas are either 1/4-wave whips or low-profile blade antennas. Both radio types are ruggedized and are powered by the vehicle's 12-v power system.

The communications center equipment is shown in figure 5-17 and consists of a tone control console, a paging encoder, and a microphone. The assembly is hard-wired to repeater station A and provides paging and control tones to operate the system from a central point. Since the equipment is not environmentally protected, it is installed in a protected location. The assembly is powered by 117 v ac but is also backed up with emergency battery power.

An alternate monitor station radio is shown in figure 5-18. The unit is basically a base station radio that operates like a mobile radio. Like the crusher console, these units require installation in a protected location. The units are powered by 117 v ac and backed up with commercial automobile batteries. The monitor station can also be remotely controlled by hard wired attachment at an intercom telephone (figure 5-19). The monitor station is 117 v ac operated with 12-v battery backup.

Complete equipment specifications are provided in paragraph 7.0.

5.2.3 Installation

All components were received and individually tested at Collins Commercial Telecommunications Division labs in Cedar Rapids, Iowa. The vhf link was an application not anticipated by the equipment manufacturer and consequently required many man-hours of Rockwell-Collins systems engineering and engineering technician time to implement. In order to satisfy the goals for desired system operation, it was necessary to perform extensive modification and testing of the uhf/vhf repeater station equipment. Coaxial cable jumpers required in the

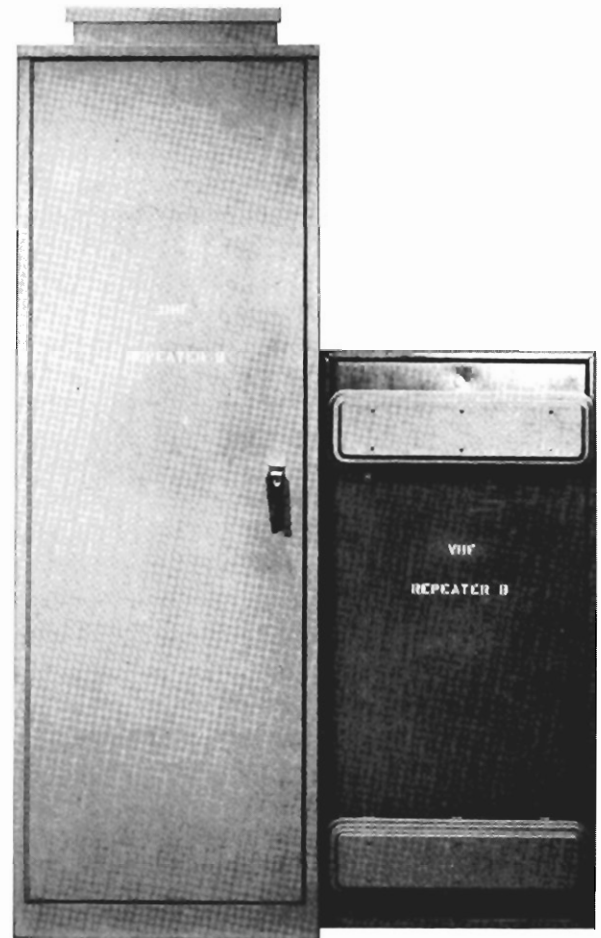

Figure 5-14. UHF/VHF Repeater Station.



Figure 5-15. Portable "Handie-Talkie".



Figure 5-16. Mobile Radio.



Figure 5-17. Communications Center Equipment.



Figure 5-18. Alternate Monitor Station.

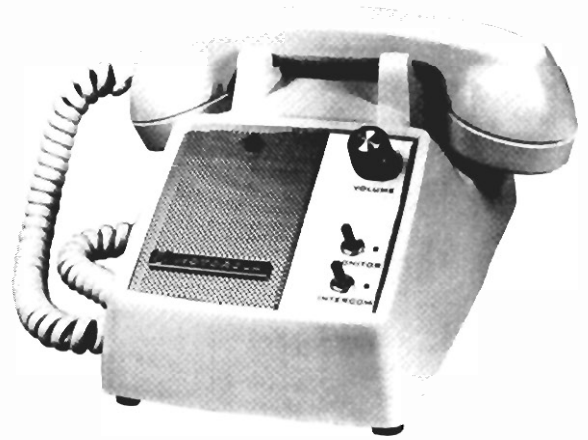

Figure 5-19. Guardhouse Intercom Telephone.

uhf/vhf repeater stations were selectively "tuned" by cutting to tested lengths. This was necessary to ensure proper receiver sensitivities and transmit power and to eliminate uhf/vhf interaction. For normal commercial application, a high-pass/low-pass filter pair could be used instead of the specially prepared lengths of coaxial cable installed in this system. Paragraph 10.0 (equipment modification) provides a detailed description of the modifications performed to the individual equipment.

Individual equipments were modified to best facilitate installation and maintenance. The uhf/vhf repeater stations were prewired and bolted to pallets for ease of transport. To best verify proper system operation, the components were assembled into a system that would be similar in operation to the one installed at the mine. The equipment was located as shown in figure 5-20, and all features of system operation were tested, including the following:

- a. Vhf zone-to-zone link.
- b. Handie-talkie to handie-talkie via uhf/vhf links.
- c. Monitor station to handie-talkie via uhf link.
- d. Remote control of alternate monitor station radio by intercom telephone.
- e. Mobile radio to alternate monitor station radio via uhf link.
- f. Communications center to all zone radios.
- g. Paging to all zones via commands from communications center.

Because "leaky-feeder" was not available, all tests were performed with 1/4-wave whip antennas on the repeaters. As can be seen in figure 5-20, there is an area labeled the "combat zone," where mobile and portable radios could receive the transmissions of both repeater stations. In this zone communications were garbled and erratic. This same effect was

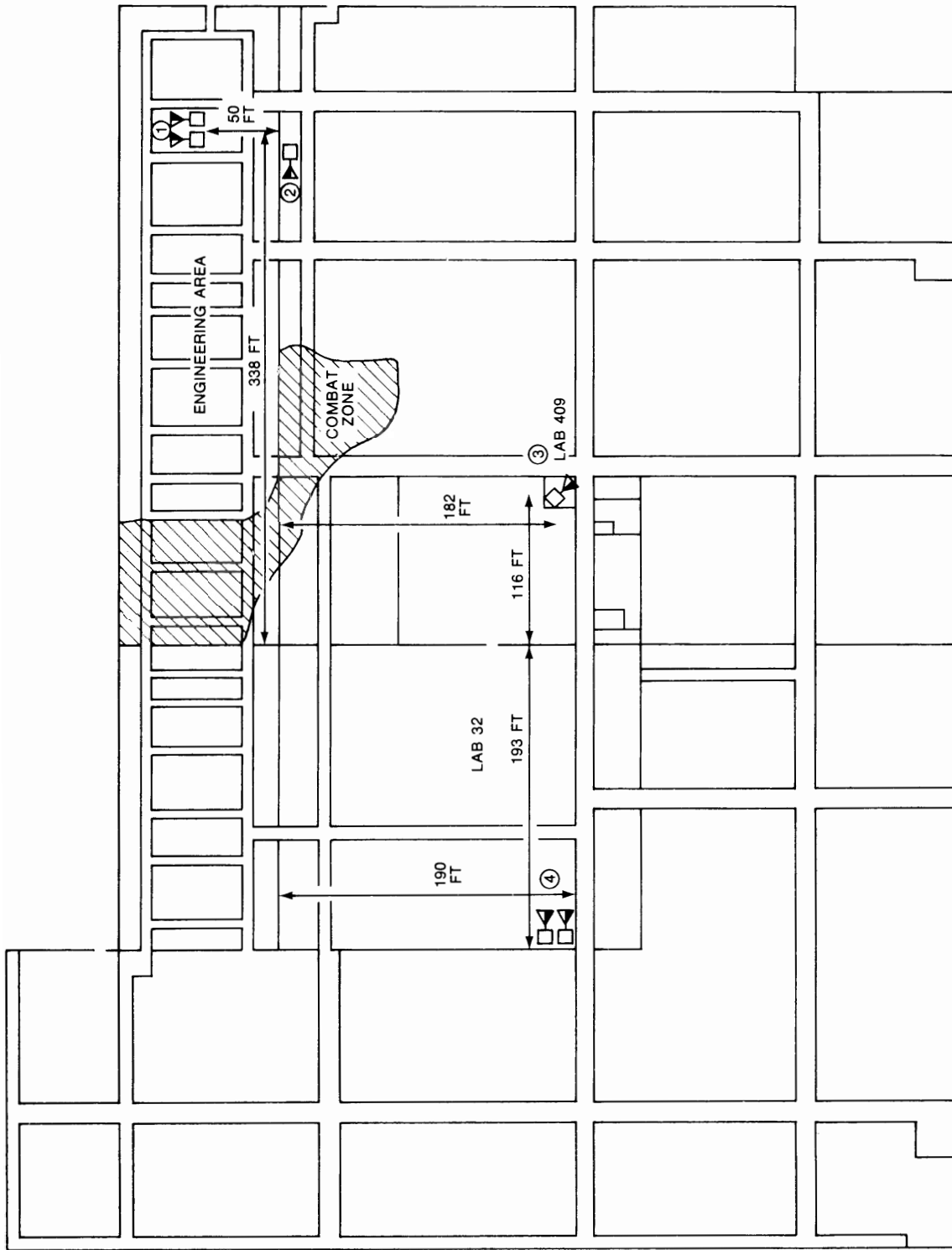

- ① REPEATER STATION B
- ② ALTERNATE MONITOR STATION
- ③ MOBIL RADIO
- ④ REPEATER STATION A/CONTROL CONSOLE EQUIPMENT

NOTE: ALL ANTENNAS ARE 1/4 WAVE WHIPS.

Figure 5-20. RF "Leaky-Feeder" Communications System Test Diagram.

expected at Grace Mine but was greatly reduced by installing a 225-foot section of nonradiating coaxial cable between repeater station B and its feedpoint to the "leaky-feeder." Interference was also reduced by not physically connecting both uhf repeaters to the same coax lines. The actual "combat zone" experienced at the mine was a section of haulageway roughly 50 to 100 feet long located between the two repeaters.

After the system was thoroughly tested and burned-in for several months, all radios were recrystallized in accordance with newly licensed frequencies and calibrated. The system then was dismantled and shipped to the mine. Refer to paragraph 8.0 for a description of calibration procedures performed.

During the assembly and testing of the system at the Rockwell-Collins labs, several survey trips were made to the mine by USBM and Rockwell-Collins personnel. These trips were made to gather installation information and to prepare mine personnel. Photographs were taken of all potential equipment sites and used to generate installation drawings. Coaxial cable and "leaky-feeder" lengths were determined and supplied to the cable manufacturer. The cable manufacturer then cut the cable to these lengths and provided on-site training of cable and connector installation procedures.

The "leaky-feeder" specifications state that the cable must be supported every 5 feet. To avoid installing several thousand anchors in the rock, the rock-bolt-supported T-bars used for the previous haulage communications system were extended to all parts of the mine and fitted with a 3/16-inch steel messenger wire. The cable (figure 5-21) was then strapped to the messenger wire with standard cable ties and spacing blocks provided by the cable manufacturer.

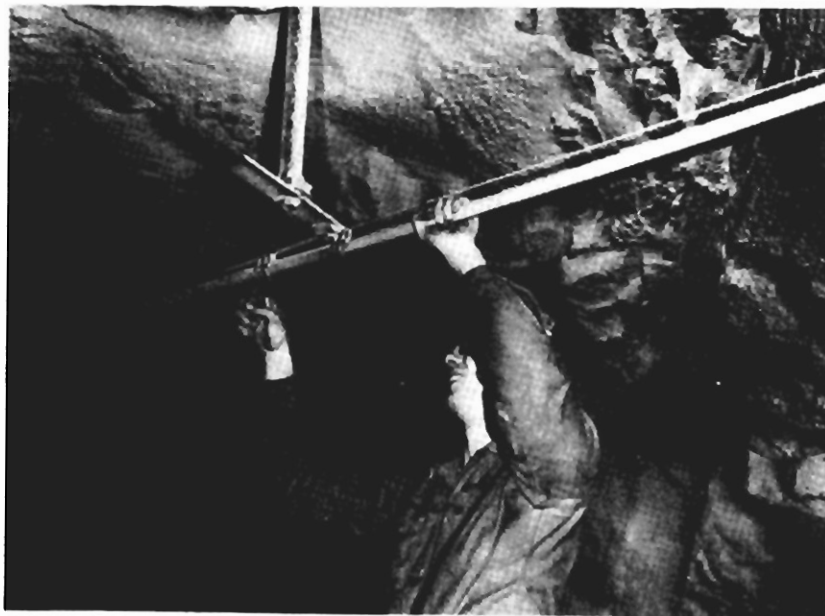

Figure 5-21. Radiating Cable Installation on Messenger Wire.

A vehicle-mounted work platform, which could be mechanically raised and lowered, with a frame for supporting cable reels, was used to perform the cable installation. Because of the disruptive nature of the cable installation, all work was performed on Sundays. This reduced

the inconveniences associated with having large cable reels in the haulageways. Some areas requiring communication service were so far removed from the main cable that stub cables had to be installed. One end of the cable was connected through a power divider (splitter) to the main cable; the other end terminated in an antenna located within a few hundred feet of the desired working area. The cable installation was performed by mine personnel with no USBM or Rockwell-Collins assistance.

When enough cable had been installed that equipment installation could proceed, all components were shipped to the mine with installation and hookup instructions. A Rockwell-Collins team was on hand to aid in unpacking, equipment, equipment placement, and final hookup and test. Because the installation had been thoroughly planned and because the system had been tested prior to shipment, the entire installation and test required only four days to complete. The repeater stations were installed in accordance with predetermined plans, as were all other equipments.

An underground crusher power substation and a crossdrift were chosen for repeater stations A and B respectively. Refer to paragraph 9.0 for criteria leading to the selection of the repeater station. Both locations were easily accessible and fairly well protected against rock falls. Furthermore, 117 v ac was available at both locations. The crusher substation would be a point of future expansion, and the repeater station could be moved to provide communications in the new areas. The crossdrift was considered to be the best point at which to access the maintenance and mined-out areas that still required communication. The crossdrift location was to be semipermanent, while the lower crusher substation location could be moved as the mine progressed. When repeater station A had been moved as far as possible while still maintaining the communications link, a third repeater station could be added to extend communications even farther. The installation of repeater station B is shown in figure 5-22. At both sites the repeater stations were wired into a dedicated 117-v ac line circuit. Super-flexible coaxial cable jumpers were used to connect the repeaters to the more rigid "leaky-feeder." These jumpers were produced by the cable manufacturer and are now included as part of their product offering.

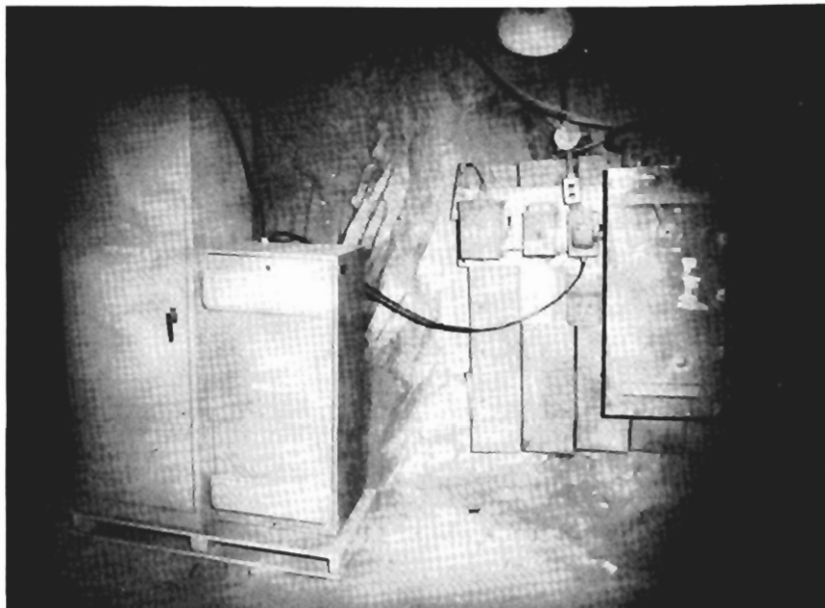

Figure 5-22. UHF/VHF Repeater Station "B" as Installed in Crossdrift.

The console area of the No. 2 crusher was selected as the location for a communications center for the system. The location was expected to be a major dispatching point for vehicles hauling ore. Personnel could overview the operation of the crusher from this location and would be available to handle fan-hole drill operator communications and personnel paging. The communications center equipment was installed in the crusher control room (figure 5-23) and hard-wired to repeater station A located 150 feet away. The room would later be enclosed and equipped with air conditioning. This would be necessary for long-term reliability, as the center equipment was not environmentally protected.

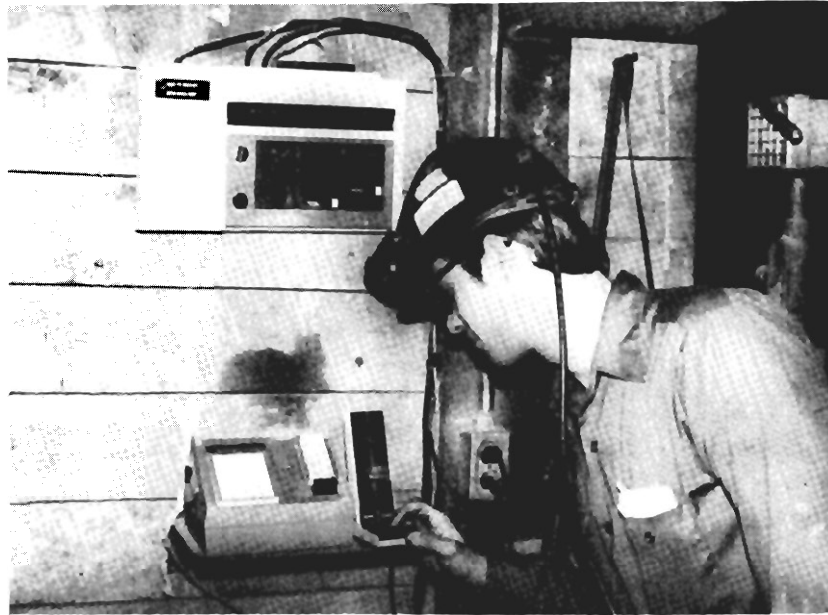

Figure 5-23. Communications Center With Page Encoder.

In the event that personnel were not at the communications center, an alternate monitor station was established at the conveyor console located near the bottom of shaft A. An operator was on duty at this location whenever ore was removed from the mine, a majority of the time during each shift. The alternate monitor station radio was positioned on top of the conveyor control console within easy access of the conveyor operator (figure 5-24). The radio operated as a standard transceiver and required no physical attachment to the system for operation. The radio, however, was equipped with remote control capability and hard-wired via twisted wire pairs to a surface intercom telephone. This intercom telephone, located at the guard-house (figure 5-25), was used to provide access to the system from the surface for emergencies. In this manner, system control could be assumed by any three of the aforementioned locations to ensure reliable communications during an emergency situation.

A second alternate monitor station was established at an underground shop. Rescue of injured personnel would be coordinated at this location through dispatch of the radio-equipped ambulance. All equipment was installed in a manner to facilitate use by the operators and provide easy access for maintenance. First the fixed portions of the system were installed and made

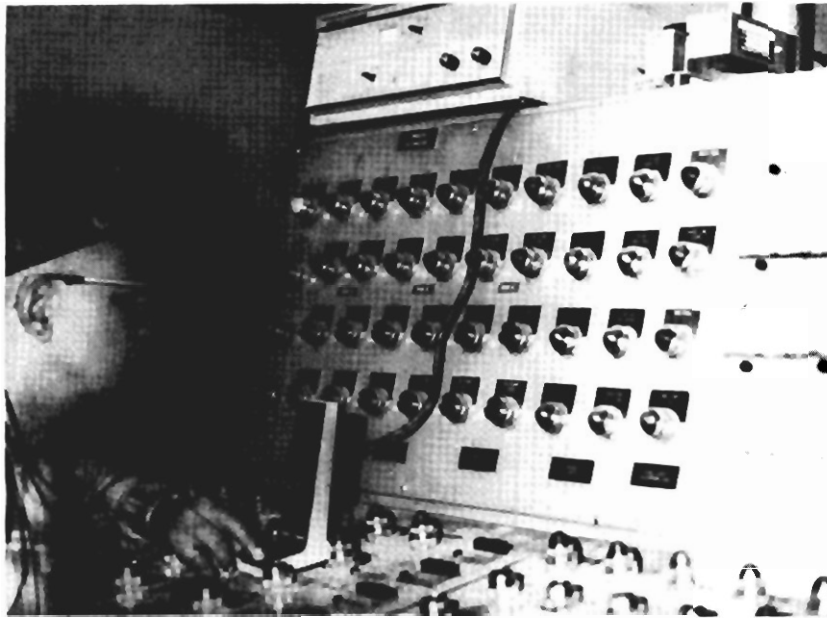

Figure 5-24. Alternate Monitor Station of Conveyor Operator's Console.



Figure 5-25. Intercom Telephone in Surface Guardhouse.

operational by the Rockwell-Collins/mine installation team. The mobile radios were installed later by mine personnel, as shown in the example in figure 5-26. Upon completion of installation, the entire system went into immediate service, providing fan-hole drill operators, roving miners, and selected vehicles with communications. Fan-hole drill operators were equipped with handie-talkies (figure 5-27), and these were used for checking in with the alternate monitor station (figure 5-24) every half-hour. The vehicles that were initially provided with radios were the electrical shop "boss-buggy," ambulance, electrical shop "uni-mog," and the lubrication vehicle. Plans were made to install radios on other vehicles, but the mine shut down operations before these plans could be completed.

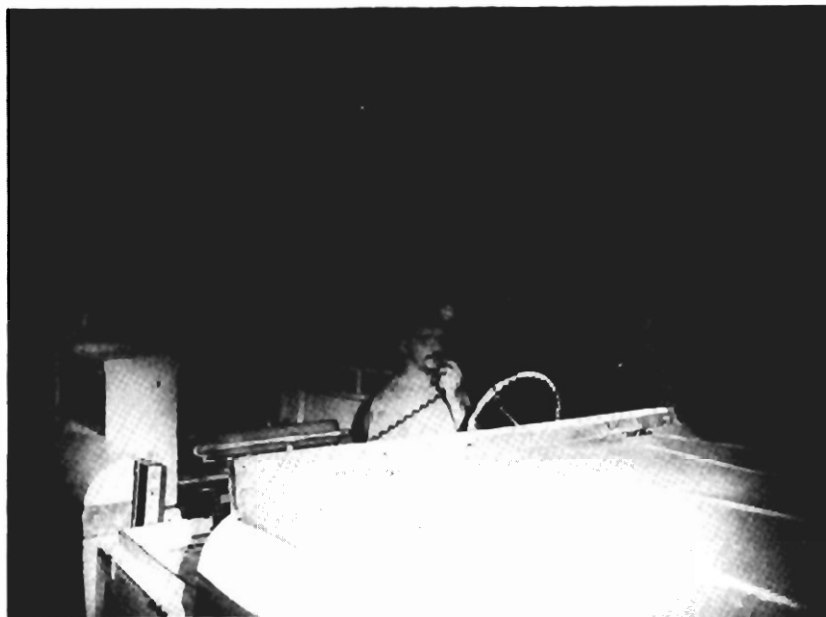

Figure 5-26. UHF Mobile Radio Mounted On Underground Ambulance.

After initial equipment installation, during which USBM and Rockwell-Collins provided technical assistance, all equipment maintenance and further installation were performed by mine personnel.

5.2.4 Follow-On Maintenance and Support

Grace Mine outfitted an underground radio shop with the necessary service equipment to maintain the communications system. A full-time Federal Communications Commission (FCC) second-class licensed radioman was trained in systems installation, operation, and maintenance. The mine was provided with manufacturer's equipment manuals and supplemental system manuals to augment equipment and system maintenance. Rockwell-Collins and USBM personnel provided training for the Grace Mine radioman, and arrangements were made to send him to the equipment manufacturer's repair schools. However,



Figure 5-27. Fan-Hole Drill Operator With Noise-Reducing Speaker-Microphone and Belt-Suspended Radio.

since the mine terminated operations, the schools were never attended. Very few problems were experienced with the system, and the mine was able to cope with add-on installation and system maintenance. USBM and Rockwell-Collins provided on-call support when required; portable and mobile radios not repairable at the mine were forwarded to Rockwell-Collins for repair.

The major problem experienced with this and other electrical systems at Grace Mine was that of dust. The dust at Grace Mine had a high content of magnetite ore and was therefore highly conductive, having a strong attraction for magnetic fields. Dust could be found in large quantities in any electrical device that generated a magnetic field, that is, vehicle starter motors, alternators, speaker coils, power transformers, etc. Dust built up until a device eventually failed because of shorting. As standard maintenance procedure, electrical systems on underground vehicles were periodically cleaned and faulty components replaced. As was expected, dust began to degrade the performance of some communications systems components. Especially vulnerable to the dust were duplexers used in the repeater stations. Since the duplexers were tuned resonant cavities, they were badly detuned when filled with dust, severely affecting system performance. It became necessary to seal all repeater station enclosures and frequently clean all equipment interiors. The sealing and cleaning seemed to greatly reduce the effects of the dust.

High humidity at Grace Mine also caused corrosion problems with connectors. Sufficient heat in repeater stations and alternate control stations kept this problem to a minimum in these equipments. The portable handie-talkies, however, experienced corroded battery contacts and required frequent cleaning. The page encoder unit, part of the communications center equipment, also required frequent cleaning of its numerous switches in order to remain fully functional. To extend the useful life of the page encoder, it was to have been encased in a protective enclosure; however, the mine terminated production before this could be done.

Other problems requiring modifications to the equipment after installation are summarized as follows:

- a. Abnormal failure rate of mobile and portable "private-line" squelch circuits. The problem was traced to a mechanical "vibrasponder" resonant reed failure because of excessive vibration and shock. The entire system was converted to carrier squelch, eliminating this problem. Since the system was underground, no problems were encountered with any other systems in the area that may have been on the same frequency.
- b. Reduced battery life of vhf repeaters. The vhf repeaters were equipped with 60-watt power amplifiers. These amplifiers were not needed for this application and therefore were disconnected. The power output dropped to 0.6 watt, greatly extending potential battery life.
- c. Reduced capability of control between surface guardhouse and conveyor console. This was a problem of equipment limitations. Modifications were performed to the equipment and resulted in the required increased capability. An additional wired pair to the surface was required, however, to implement this change.

One advantage of using the vhf link between the two uhf zones was verified during a trip made to the mine to perform evaluation tests. Tests were underway to measure vhf signal levels in the cable located between the two uhf zones. The levels were particularly low following one power splitter. Examination of the splitter found it to be broken with no dc continuity between the two halves. Because of the operating characteristics of the cable at vhf frequencies and because of the reserve power available at vhf, the break had never been detected in the operation of the system and would probably still be there if it hadn't been for the measurements being performed.

Only once during the course of this program did a repeater fail underground, and this problem was identified and corrected by mine personnel. Reliability of the system, in service since October 1975, has been excellent, with negligible downtime. After installation, several series of measurements were made to record system performance. The data from these tests are shown in paragraph 8.2.

6.0 RECOMMENDATIONS/CONCLUSIONS

A wireless communications system that satisfies the objectives of personnel and vehicular underground mine communications had been demonstrated. Worker and management acceptance of the system had been excellent, and the system was expanding to keep pace with the demands of new mine development when termination of production at Grace mine resulted in turning off the system. The hoist communications system had provided the voice communications necessary between the hoistman and cage for a safe and efficient hoisting operation.

The Engineering and Administrative Services Program has resulted in significant improvements in hoist communication and "leaky-feeder" communications systems. Since the installation in Grace Mine, several other mines have installed commercial "leaky-feeder" systems to meet critical communications needs. Improved versions of the hoist radio system have been installed at the Sunshine Silver Mine in Big Creek, Idaho (Section III), and the Robena Coal Mine in southwestern Pennsylvania (Section II), also under provisions of Engineering and Administrative Services Contract SO133035.

Through various Bureau of Mines-sponsored technology transfer seminars, the information gathered at Grace Mine has been presented to other mine owners and operators in an effort to promote the use of this technology. Grace Mine and Rockwell-Collins have taken an active role in these seminars, providing first-hand design, installation, and maintenance experience.

Tours have been conducted at Grace, Robena, and Sunshine Mines so that interested personnel from other mines and equipment manufacturers could witness, firsthand, the performance of the communications and confer directly with personnel from those mines using the systems.

The basic goals at Grace Mine were to provide wireless communications with roving miners and between vehicles and the transmission of voice, geological, and environmental parameters to the surface. The hoist and "leaky-feeder" systems, installed and maintained under provisions of USBM Contract SO133035, and the mine-wide monitoring system, installed and maintained directly by USBM, have been the means of satisfying these goals. Since the initial site survey in January 1974, through system acceptance in November 1976, there has been strong cooperation between the USBM/Rockwell-Collins team and the mine. Had it not been for Grace Mine's excellent support, all the program goals would not have been satisfied. All phases of the program have had favorable results.

The hoist communications system, intended to replace an existing system, improved communication between the hoistman and the cage. Interference problems associated with the previous system were eliminated, and overall reliability was improved. Acceptance of the system by mine personnel was good, with complete faith being given to the system operation.

The rf "leaky-feeder" communications system replaced a previous haulage communications system, extended communications to roving miners, and replaced the existing fan-hole drill operator communications system. The system was immediately accepted by mine personnel, as it was a tremendous improvement over the previous system. Fan-hole drill operators were provided with a more reliable system that could be more easily used. Dispatch of the ambulance was of utmost importance, and this feature was used on several occasions. Injuries were possibly reduced because of the ability to control the movement of the ambulance via a central dispatch. Selected vehicles and individuals were easily coordinated and located because of the "leaky-feeder" communications system, thus improving production and safety. All areas of the mine requiring communications were thus provided

communications. The paging feature of the system was not necessary for mine operation and therefore was unused. The concept was demonstrated, however, for future applications.

Reviewing the installation phase reveals certain improvements that could be incorporated into future systems. The use of vhf repeaters to link two uhf zones was successfully demonstrated at Grace Mine. However, because of the complexities involved with the repeater station interconnects and because using a vhf link exposes more equipment to failure, it is recommended that a vhf link not be used in future systems unless absolutely necessary. An audio link, either multiplexed onto the coax or via wired pairs, would be less complicated and would still provide the necessary interconnection between repeater stations. Other repeater links are also available. The advantages outlined previously are far outweighed by the effort required to make the system function* and the increased maintenance and repair technology required after installation. At Grace Mine, where a trained radioman was on site to troubleshoot the system, equipment failures could be easily located and corrected. At sites lacking a qualified technician, failures of the vhf link interconnection would be disastrous. In addition, since the equipment was not intended for the application demonstrated at Grace Mine, technology and manufacturer's support of vhf link equipment are limited. Conventional linking methods would be more easily obtained and would be within the installation and maintenance capabilities of most mine electricians.

Had an audio link been used instead of the vhf link, the system operation would have been greatly simplified. However, it should be pointed out that a primary goal of the Engineering and Administrative Services Program was to demonstrate off-the-shelf technology capability. By designing, installing, and testing the system at Grace Mine with the vhf link, complete state-of-the-art technology was therefore demonstrated.

The conversion of underground equipment to carrier squelch operation after installation revealed weaknesses in the portable and mobile transceivers. However, in view of the fact that "private-line" squelch is not necessarily required in underground operations, it became a problem of little concern once the radios were modified. In future applications where the radio signal may be extended to the surface, consideration should be given to correcting the problem of "private-line" squelch circuit failures experienced at Grace Mine. In addition, shockmounting of vehicular radios or selection of alternate equipment manufacturers using solid-state subaudible tone squelch may be required.

The importance of periodic maintenance cannot be overemphasized. Underground mine environments are especially harsh, and equipments expected to survive require special packaging. Combined with adequate protection, routine maintenance of all equipments is necessary to ensure long-term reliability.

The maintenance schedule established at Grace Mine on the hoist communications and rf "leaky-feeder" communications systems exposed potential problems before they affected system performance. Periodic performance tests also helped identify trends in system operation in an effort to correct long-term problems.

As can be seen by the test data in paragraph 8.2, the components of both systems are, for the most part, within operating tolerances. Those items outside tolerance limits would have been calibrated had the mine not terminated production. The reliability of all equipments has been excellent, requiring only minimal maintenance. Both systems could be expected to survive many more years with proper maintenance.

*(Refer to paragraph 10.0, equipment modification)

The hoist communications system remains operational, and is being used by maintenance personnel remaining at Grace Mine. The rf "leaky-feeder" system has been disabled, and all underground equipment has been fitted with internal heaters. It is anticipated that the system may be relocated to a similar mining operation; however, at the time of writing this report, no information was available in regard to the disposition of equipment.

7.0 EQUIPMENT SPECIFICATIONS

7.1 Hoist Radio Communications System

Following are the electrical and mechanical specifications of the hoist radio communications system.

General

Frequency.....	Frequency diversity system, 35 and 52 kHz.
Modulation.....	Narrow-band FM (12F3), ± 3 -kHz deviation.
Supply voltage.....	Battery operated (25 amp-hr); nominal 12.0 v dc; power supply/charger, 115 v ac, 60 Hz, single-phase, capable of operating radio and charging battery.
Temperature range.....	-30 to +50 °C (-20 to 120 °F).

Nominal current (at 12 v)

Transmit

High power.....	(10 w/channel) 4.2 amp dc.
Medium power	(5 w/channel) 2.7 amp dc.
Low power	(2 w/channel) 2.1 amp dc.

Receive

Squelched.....	0.25 amp dc.
Unsquelled.....	0.65 amp dc.

Receiver

Diversity	Simultaneously receives on 35 and 52 kHz.
Audio switching.....	Voting logic allows stronger signal to provide audio output.
Sensitivity.....	10 μ v for 20-db quieting, each channel.
Squelch	Operates at 10 μ v with minimum of 40-db quieting range.
Input impedance	50 ohms.
Bandwidth	14 kHz at -6-db points.
Selectivity.....	60 db at ± 30 kHz.
Frequency stability.....	$\pm 0.25\%$.

Audio output..... 5 w into 8-ohm speaker; 0 db mw into 600-ohm handset earpiece.

Audio distortion..... 5% distortion at 5-w output.

Spurious and image rejection..... 60 db down; 80 db down at 88, 100, 115, and 145 kHz.

Transmitter

Diversity Two frequencies, 35 and 52 kHz, transmitted simultaneously.

Power output 10 w per channel.

Output impedance 50 ohms.

Audio input impedance..... 150 ohms.

Audio input level 250 mv to 2.5 v.

Audio response +1 db to -3 db from 300 to 3000 Hz.

Frequency stability..... ±0.25%.

Spurious and harmonic emission..... -35 db from carrier; frequencies at 88 and 100 kHz, 60 db down.

Alarm capability..... Audio tone automatically transmitted.

Mechanical

Transceiver

Size 4.5 x 11 x 7.8 in.

Weight 14 lb.

Power supply/battery charger

Size 8.5 x 9.4 x 16.5 in.

Weight 41 lb.

Sealed battery pack

Size 7.3 x 9.3 x 7.3 in.

Weight 26 lb.

Station control module

Size 13 x 5.5 x 4.1 in.

Weight..... 5 lb.

Headframe coupler

Size 8 x 12 x 3 in.

Weight 10.5 lb.

Cage coupler

Size 10.1 x 10.1 x 9 in.

Weight 9.5 lb.

Manufacturer..... Developed for the United States Bureau of Mines under Contract HO230034 by Collins Commercial Telecommunications Division, Rockwell International.

7.2 "Leaky-Feeder" Communications System

Following are the electrical and mechanical specifications of the "leaky-feeder" communications system.

"Leaky-feeder" cable

	<u>1/2-in Radiax®</u>	<u>7/8-in Radiax</u>	<u>7/8-in Cert®</u>
Attenuation at 450 MHz.....	4.0 db-100 ft	1.2 db-100 ft	2.9 db-100 ft
Attenuation at 150 MHz.....	1.9 db-100 ft	0.6 db-100 ft	0.72 db-100 ft
Coupling loss 20 ft at 450 MHz.....	61 db	80 db	60 db
VSWR.....	1.3	1.3	1.2
Impedance.....	50 ohms	50 ohms	50 ohms
Diameter over jacket.....	0.62 in	1.10 in	-
Cable weight	0.16 lb-ft	0.44 lb-ft	-
Manufacturer.....	Andrew Corp.	Andrew Corp.	Times Wire and Cable

Portable radios

Receiver sensitivity..... 0.5 μv at 20-db quieting.

Receiver frequency..... 451.825 MHz ±0.0005%.

Reference to specific brands, equipment, or trade names in this report is made to facilitate understanding and does not imply endorsement by the USBM.

Transmit power 4.0 w.
Transmit frequency 451.825 or 456.825 MHz $\pm 0.0005\%$.

Power at 15 v dc

Standby..... 5.5 ma dc.
Receive 65 ma dc.
Transmit..... 895 ma dc.

Size 7.58 x 3.19 x 1.75 in.

Weight 27.3 oz.

Manufacturer..... Motorola, Inc.

Mobile radios

Receiver sensitivity..... 0.8 μ v at 20-db quieting.

Receiver frequency..... 451.825 MHz $\pm 0.0005\%$.

Transmit power 8.0 w.

Transmit frequency 456.825 MHz $\pm 0.0005\%$.

Power

Standby..... 0.04 amp dc.
Receive 1.30 amp dc.
Transmit..... 2.80 amp dc.

Size 2.69 x 8.75 x 9.75 in.

Weight 7 lb.

Manufacturer..... Motorola, Inc.

Vhf repeaters

Receiver sensitivity..... 0.5 μ v at 20-db quieting.

Receiver frequency..... 152.915 or 154.625 MHz $\pm 0.0005\%$.

Transmit power..... 60 w reduced to 0.6 w (by removing pa).

Transmit frequency 152.915 or 154.612 MHz $\pm 0.0005\%$.

Power

Standby..... 0.63 amp ac.

Transmit 3.15 amp ac.

Size 22.0 x 46.0 x 20.0 in.

Weight 100 lb.

Manufacturer..... Motorola, Inc.

Uhf repeaters

Receiver sensitivity..... 0.5 μ v at 20-db quieting.

Receiver frequency..... 456.825 MHz \pm 0.0005%.

Transmit power 12 w.

Transmit frequency 451.825 MHz \pm 0.0005%.

Power

Standby..... 0.8 amp ac.

Transmit 3.0 amp ac.

Size 23.75 x 70.0 x 21.5 in.

Weight 180 lb.

Manufacturer..... Motorola, Inc.

Station monitor radios

Receiver sensitivity..... 0.5 μ v at 20-db quieting.

Receiver frequency..... 456.825 MHz \pm 0.0005%.

Transmit power 0.15 to 15 w.

Transmit frequency 451.825 MHz \pm 0.0005%.

Power

Standby..... 0.40 amp ac.

Transmit 3.50 amp ac.

Size 6.25 x 16.75 x 18.5 in.

Weight 50 lb.

Manufacturer..... Motorola, Inc.

Communications center console

Control tones 600 to 2000 Hz.

Audio output 5 w into 8 ohms.

Power

Paging encoder

Standby..... 0.04 amp dc.

Transmit 0.17 amp dc.

Tone console

Standby..... 0.3 amp dc.

Receive 1.4 amp dc.

Transmit 0.5 amp dc.

Size

Paging encoder 8.25 x 8.25 x 8.75 in

Tone console 4.0 x 15.0 x 10.0 in.

Weight

Paging encoder 10 lb.

Tone console 12 lb.

Manufacturer..... Motorola, Inc.

Intercom telephone

Audio output 500 mw into 16 ohms.

Line impedance..... 600 ohms balanced.

Power

Standby..... 0.075 amp dc.

Receive 0.170 amp dc.

Transmit 0.600 amp dc.

Size 5.0 x 9.19 x 9.0 in.

Weight 5 lb.

Manufacturer..... Motorola, Inc.

8.0 PERFORMANCE TESTS

8.1 Hoist Radio Performance Tests

Performance tests were made at Rockwell-Collins on the hoist radio system prior to installation during August 1974. After system installation, measurements were performed during January 1975, June 1975, and November 1976 -- four, nine, and twenty months, respectively, from the date of installation. No calibration was performed on the equipment, only the periodic maintenance. Comparing the test data which follows with the specifications in appendix A, one can see that the equipment is still operating within specified limits. The signal strengths, as displayed in table 8-1, seem to indicate operational variance but no appreciable degradation in system performance.

All equipment measurements were made using recently calibrated test equipment by industry-approved methods. The signal strengths were taken at the hoist room transceiver across the coupler input. The cage transceiver was keyed on and the cage lowered down the shaft, with measurements taken at the hoist room. It was determined at Grace Mine and other such installations that signal strength was highly variable and tended to be a function of not only distance between couplers but proximity of cage to shaft, shaft temperature, and shaft wetness as well.

a. Transmit Power (watts)

TRANSCIVER LOCATION	CHANNEL	POWER SETTING	BEFORE INSTALLATION	MONTHS AFTER INSTALLATION	
				9	20
Hoist room	A	High	10.1	14.6	11.5
		Medium	4.4	-	6.2
		Low	2.0	-	1.8
	B	High	10.4	14.6	11.6
		Medium	3.7	-	5.4
		Low	1.3	-	1.6
Cage	A	High	11.3	7.5	6.6
		Medium	5.6	4.4	6.2
		Low	1.6	-	1.6
	B	High	11.3	8.0	8.0
		Medium	5.2	5.8	7.8
		Low	3.7	-	2.3

b. Transmit Frequency (Hz)

TRANSCEIVER LOCATION	CHANNEL	BEFORE INSTALLATION	MONTHS AFTER INSTALLATION	
			9	20
Hoist room	A	35,008	35,005	35,010
	B	52,001	52,032	52,046
Cage	A	35,000	34,989	35,002
	B	52,004	52,035	52,004

c. Transmit Deviation (kHz)

TRANSCEIVER LOCATION	CHANNEL	BEFORE INSTALLATION	MONTHS AFTER INSTALLATION	
			9	20
Hoist room	A	±3.2	±2.8	-
	B	±2.9	±2.4	-
Cage	A	±3.0	-	-
	B	±2.6	-	-

d. Receiver Sensitivity (μv for 20-db quieting)

TRANSCEIVER LOCATION	CHANNEL	BEFORE INSTALLATION	MONTHS AFTER INSTALLATION	
			9	20
Hoist room	A	2.24	1.40	2.00
	B	0.32	1.90	1.40
Cage	A	0.56	2.60	2.40
	B	0.71	2.40	3.15

e. Audio Power (watts rms)

TRANSCIVER LOCATION	BEFORE INSTALLATION	MONTHS AFTER INSTALLATION	
		9	20
Hoist room	5.0	4.94	3.92
Cage	5.0	5.00	4.21

f. DC Current Drain (amp)

TRANSCIVER LOCATION	BEFORE INSTALLATION	MONTHS AFTER INSTALLATION	
		9	20
Cage Only			
Standby squelched	-	0.31	0.31
Unsquelched	-	1.10	1.26
Tx-hi	-	3.40	3.15
Tx-med	-	2.80	3.10
Tx-lo	-	2.12	2.00

Table 8-1. Signal Strengths at Discrete Cage Depths.

LOCATION	SIGNAL STRENGTH (mv)	
	CHANNEL A	CHANNEL B
4 months after installation		
Collar	0.085	0.13
-2000 ft	30.000	3.50
-2400 ft	0.400	6.00

Table 8-1. Signal Strengths at Discrete Cage Depths (Cont).

LOCATION	SIGNAL STRENGTH (mv)	
	CHANNEL A	CHANNEL B
9 months after installation		
Collar	1.40	1.90
-500 ft	5.57	4.25
-1000 ft	4.43	6.01
-1500 ft		2.68
-2000 ft	14.00	37.90
-2400 ft	2.22	4.25
20 months after installation		
Collar	0.63	1.26
-500 ft	0.53	1.39
-1000 ft	2.09	3.63
-1500 ft	2.53	3.16
-2000 ft	2.12	2.63
-2400 ft	1.83	2.37
-2600 ft	1.71	2.24
All measurements were taken at the coupler input to the hoist room transceiver with the cage transceiver on high-power transmit (figure 8-1).		

8.2 System Performance Data -- "Leaky-Feeder" Communications System

During the follow-on maintenance and support phase of this program, a comprehensive set of measurements were performed on the "leaky-feeder" communications system to evaluate system operation. These measurements included equipment and system operating levels. The measurements were performed one year after system installation (during November, 1976) and two years after installation (during October, 1977). Some measurements were also performed in February, 1977, but did not include all equipments. The equipment, as installed, conformed to the specifications listed in paragraph 7.0. No calibration was performed during this period, only monthly cleaning of the repeater stations. Comparing the specifications of paragraph 7.0 with the test data, which follows, one can see the performance trends of the

equipment. Most equipments seem to have remained within tolerances, with only a few items requiring calibration or repair. The signal strengths, as displayed, indicate little or no degradation in cable performance.

All equipment measurements were made using recently calibrated test equipment by industry-approved methods. The receive signal strengths were made using a USBM-provided EMC-25, calibrated to 451.825 MHz. Three measurements were taken at each location (left, middle, and right) to give an average reading. Frequent retuning of the EMC-25 was performed to ensure accurate readings. The battery-powered EMC-25 was transported on the back of the same vehicle used to install the cable.

The transmit signal strength measurements were accomplished by attaching a strip chart recorder to the internal metering socket of the uhf repeaters, thus giving a dc voltage that was a function of receiver signal level. A calibration curve was then run by inserting known signals into the receiver to produce given movements on the strip chart. A variable step attenuator was inserted between the receiver and the "leaky-feeder" to ensure that the receiver stage was in a linear region of operation. By walking (or driving) the drifts containing "leaky-feeder" with a transmitting portable (or mobile) transceiver, a graph was produced that represented signal strength as a function of distance from the repeater station. Batteries in the portables were changed often to ensure constant power output. With the calibration curve, it was possible to interpret the data shown in figures 8-2, 8-3, and 8-5.

It was determined that signal strength, whether transmitted or received, was highly variable and tended to be a function of distance from measuring (or transmitting) device to cable; distance to repeater; humidity; dust content; and antenna polarization.

a. Transmit Power

UNIT DESCRIPTION	POWER (watts rms)		
	*SPECIFIED	1 YEAR	2 YEARS
Uhf repeater A (pa)	12.0	18.30	16.65
Uhf repeater A (duplexer)	7.6	7.40	3.15
Uhf repeater B (pa)	12.0	11.60	12.21
Uhf repeater B (duplexer)	7.6	2.50	2.37
Vhf repeater A (pa)	60.0	59.00	** 0.46
Vhf repeater A (duplexer)	40.0	36.00	** 0.18
Vhf repeater B (pa)	60.0	19.60	** 0.61
Vhf repeater B (duplexer)	40.0	15.70	** 0.30
Skip console station radio	0.15 to 15	5.20	4.59
Diesel shop station radio	0.15 to 15	4.20	4.14

UNIT DESCRIPTION	POWER (watts rms)		
	*SPECIFIED	1 YEAR	2 YEARS
Mobile (PK758T)	8.0	-	5.99
Mobile (PK759T)	8.0	8.50	7.03
Mobile (PK760T)	8.0	-	5.77
Mobile (PK761T)	8.0	10.25	8.51
Mobile (PK762T)	8.0	-	-
Mobile (PK763T)	8.0	10.00	8.88
Mobile (PK764T)	8.0	9.65	9.03
Mobile (PK765T)	8.0	8.75	7.99
Mobile (QK751Z)	8.0	11.20	-
Mobile (QK752Z)	8.0	11.10	-
Portable (53D8F)	4.0	-	4.66
Portable (53D9T)	4.0	-	4.51
Portable (54D0T)	4.0	3.90	4.22
Portable (54DIT)	4.0	3.80	4.88
Portable (PO7D4T)	4.0	4.90	4.88
Portable (PO7D5T)	4.0	3.90	4.07
Portable (PO7D6T)	4.0	4.60	5.25
Portable (PO7D7T)	4.0	4.20	-
Portable (PO7D8T)	4.0	3.80	-
Portable (PO7D9T)	4.0	4.40	4.81

*Minimum power expected.

**With vhf power amplifier removed, specified power output declines to 600 mw.

b. Transmit Frequency

UNIT DESCRIPTION	FREQUENCY (MHz)		
	*SPECIFIED	1 YEAR	2 YEARS
Uhf repeater A	451.825	451.82442	451.825340
Uhf repeater B	451.825	451.82449	451.824740
Vhf repeater A	152.915	152.91510	152.914720
Vhf repeater B	154.625	154.62529	154.625440
Skip console station radio	456.825	456.82538	456.825861
Diesel shop	456.825	456.82505	456.825024
Mobile (PK758T)	456.825	-	456.825070
Mobile (PK759T)	456.825	456.82470	456.824816
Mobile (PK760T)	456.825	-	456.824450
Mobile (PK761T)	456.825	456.82480	456.824635
Mobile (PK762T)	456.825	-	-
Mobile (PK763T)	456.825	456.82494	456.824907
Mobile (PK764T)	456.825	456.82405	456.824430
Mobile (PK765T)	456.825	456.82467	456.824527
Mobile (QK751Z)	456.825	456.82489	-
Mobile (QK752Z)	456.825	456.82509	-
Portable (53D8T)	456.825 (F1)	-	456.824590
Portable (53D8T)	451.825 (F2)	-	451.823792
Portable (53D9T)	456.825 (F1)	-	456.824433
Portable (53D9T)	451.825 (F2)	-	451.823960
Portable (54DOT)	456.825 (F1)	456.82512	456.825483
Portable (54DOT)	451.825 (F2)	456.82369	451.824219
Portable (54DIT)	456.825 (F1)	456.82511	456.826455

UNIT DESCRIPTION	FREQUENCY (MHz)		
	*SPECIFIED	1 YEAR	2 YEARS
Portable (54D1T)	451.825 (F2)	451.82369	451.826489
Portable (P07D4T)	456.825 (F1)	456.82395	456.824423
Portable (P0704T)	451.825 (F2)	451.82348	451.823781
Portable (P07D5T)	456.825 (F1)	456.82476	456.825269
Portable (P07D5T)	451.825 (F2)	451.82477	451.825236
Portable (P07D6T)	456.825 (F1)	456.82478	456.825127
Portable (P07D6T)	451.825 (F2)	451.82123	451.821724
Portable (P07D7T)	456.825 (F1)	456.82193	-
Portable (P07D7T)	451.825 (F2)	451.82123	-
Portable (P07D8T)	456.825 (F1)	456.82470	-
Portable (P07D8T)	451.825 (F2)	451.82501	-
Portable (P07D9T)	456.825 (F1)	456.82467	456.824922
Portable (P07D9T)	451.825 (F2)	451.82490	451.824821

*Nominal frequency $\pm 0.0005\%$.

c. Receiver Sensitivity

UNIT DESCRIPTION	SENSITIVITY (μv at 20-db quieting)		
	*SPECIFIED	1 YEAR	2 YEARS
Uhf repeater A (receiver)	0.50	1.00	1.33
Uhf repeater A (duplexer)	0.63	-	3.15
Uhf repeater B (receiver)	0.50	1.30	1.23
Uhf repeater B (duplexer)	0.63	-	1.99
Vhf repeater A (receiver)	0.50	0.40	0.51

UNIT DESCRIPTION	SENSITIVITY (μv at 20-db quieting)		
	*SPECIFIED	1 YEAR	2 YEARS
Vhf repeater A (duplexer)	0.61	-	**348.00
Vhf repeater B (receiver)	0.50	0.38	0.41
Vhf repeater B (duplexer)	0.61	-	** 91.77
Skip console station radio	0.50	2.00	2.56
Diesel shop station radio	0.50	0.66	0.70
Mobile (PK758T)	0.50	-	0.60
Mobile (PK759T)	0.50	0.62	0.44
Mobile (PK760T)	0.50	-	0.54
Mobile (PK761T)	0.50	0.78	0.85
Mobile (PK762T)	0.50	-	-
Mobile (PK763T)	0.50	1.30	2.69
Mobile (PK764T)	0.50	0.79	0.66
Mobile (PK765T)	0.50	1.00	0.63
Mobile (QK751Z)	0.50	-	-
Mobile (QK752Z)	0.50	-	-
Portable (P53D8T)	0.50	-	0.41
Portable (P53D9T)	0.50	-	0.40
Portable (P54D0T)	0.50	0.60	0.40
Portable (P54D1T)	0.50	0.36	0.92
Portable (P07D4T)	0.50	0.17	0.41
Portable (P07D5T)	0.50	0.51	0.52
Portable (P07D6T)	0.50	0.37	0.38
Portable (P07D7T)	0.50	0.20	-

UNIT DESCRIPTION	SENSITIVITY (μv at 20-db quieting)		
	*SPECIFIED	1 YEAR	2 YEARS
Portable (P07D8T)	0.50	0.24	-
Portable (P07D9T)	0.50	0.36	0.63

*Maximum specified level expected to give 20-db quieting.
**Due to duplexer detuning.

d. Voltage Standing Wave Ratio

LOCATION	VSWR	
	1 YEAR	2 YEARS
Into coax at repeater A (uhf)	1.23	1.33
Into coax at repeater A (vhf)	2.25	4.40
Into coax at repeater B (uhf)	1.90	1.53
Into coax at repeater B (vhf)	1.33	1.88

e. Transmit/Receive Signal Strength

TEST	DATE TAKEN	TABLE	FIGURE
Transmit signal strength (mobile)	Nov 1976	B-2	B-2
Transmit signal strength (portable)	Nov 1976	B-3	B-3
Antenna polarization	Nov 1976	-	B-4
Receive signal strength	Feb 1977	B-4	B-5
Perpendicular to coax (Cert)	Feb 1977	B-5	B-6
Perpendicular to coax (Radiax)	Feb 1977	B-6	B-7
Fan-hole drift at 615E	Feb 1977	B-7	B-8
Receive signal strength	Oct 1977	B-8	B-9
Transmit signal strength	Oct 1977	B-9	B-10

Transmit signal strength is defined as the rf signal transmitted by a mobile/portable unit that is received (detected) at a repeater station; whereas receive signal strength is the reverse, that is, the rf signal transmitted by a repeater station that is received by a portable/mobile unit.

Table 8-2. Transmit Signal Strength (Mobile) (Figure 8-2).

SIGNAL STRENGTH (μv)	DISTANCE (ft)	LOCATION
25.3	0	Shop air doors
32.6	90	
41.1	170	No. 1 crossdrift
51.5	220	
68.9	270	
72.4	320	
102.5	370	No. 2 crossdrift
135.7	420	
347.8	480	
282.0	530	
450.0	590	
525.0	640	No. 3 crossdrift
324.0	700	
500.0	740	
800.0	780	
410.0	820	
396.0	860	
549.0	900	
445.0	950	No. 4 crossdrift
841.0	1000	
1090.0	1040	
410.0	1090	
258.0	1120	
450.0	1160	

Table 8-2. Transmit Signal Strength (Mobile) (Figure 8-2) (Cont).

SIGNAL STRENGTH (μV)	DISTANCE (ft)	LOCATION
345.0	1240	No. 5 crossdrift
152.0	1320	
117.0	1380	
108.0	1440	
128.0	1500	
128.0	1550	No. 6 crossdrift
303.0	1610	
429.0	1670	
450.0	1750	
585.0	1790	
654.0	1870	No. 7 crossdrift
382.0	1910	
297.0	1970	
297.0	2030	
382.0	2100	Crusher access
41.8	2130	
72.4	2160	
58.5	2200	
39.7	2240	
35.4	2280	
29.0	2310	
29.7	2340	
34.0	2370	608-609 split

Table 8-3. Transmit Signal Strength (Portable) (Figure 8-3).

SIGNAL STRENGTH (μ v)	DISTANCE (ft)	LOCATION
26.1	0	4U skip console
35.6	40	
85.0	95	
68.9	125	
67.0	160	Air doors
36.8	200	
28.3	230	
36.8	265	
26.8	300	
38.0	335	Mechanic shop
45.0	360	
46.3	385	
52.5	410	
221.0	440	Ambulance
150.0	465	
115.0	490	Air door
41.0	515	
30.0	540	
28.0	550	
34.0	570	
37.0	600	
22.0	625	
32.0	670	No. 1 crossdrift
37.0	685	

Table 8-3. Transmit Signal Strength (Portable) (Figure 8-3) (Cont).

SIGNAL STRENGTH (μv)	DISTANCE (ft)	LOCATION
38.0	715	No. 2 crossdrift
39.0	750	
40.0	785	
48.0	815	
48.0	850	
115.0	885	
158.0	915	
213.0	950	
304.0	985	
282.0	1015	
314.0	1050	No. 3 crossdrift
185.0	1085	
136.0	1110	
152.0	1135	
251.0	1165	
408.0	1200	
408.0	1235	
314.0	1275	
345.0	1300	No. 4 crossdrift
395.0	1335	
314.0	1375	
324.0	1415	
450.0	1450	
600.0	1490	

Table 8-3. Transmit Signal Strength (Portable) (Figure 8-3) (Cont).

SIGNAL STRENGTH (μV)	DISTANCE (ft)	LOCATION
700.0	1535	No. 5 crossdrift
600.0	1565	
347.0	1600	
361.0	1635	
243.0	1665	
276.0	1700	
234.0	1735	
234.0	1765	
114.0	1800	
85.0	1835	
56.0	1865	
74.0	1915	
96.0	1965	
158.0	2000	
119.0	2035	
178.0	2065	
194.0	2090	
311.0	2140	
311.0	2170	
345.0	2210	
450.0	2235	
158.0	2265	
293.0	2290	
240.0	2320	

Table 8-3. Transmit Signal Strength (Portable) (Figure 8-3) (Cont).

SIGNAL STRENGTH (μV)	DISTANCE (ft)	LOCATION
169.0	2350	No. 7 crossdrift
101.0	2385	
185.0	2415	
169.0	2450	
112.0	2485	
90.0	2515	
79.0	2560	
108.0	2590	Crusher access
65.0	2615	
36.0	2635	
30.0	2650	
24.0	2665	
24.0	2685	
13.0	2700	
16.0	2715	
12.0	2735	
10.0	2750	E/W drainage
10.0	2765	
17.0	2785	
15.0	2800	
7.0	2835	608-609 split

Table 8-4. Receive Signal Strength (Figure 8-5).

SIGNAL STRENGTH (mv/metre)	DISTANCE (ft)	LOCATION
7.38	0	4-v console
2.44	100	Air doors
2.91	225	Shop
0.75	438	Back air door
0.85	525	Park bay
1.01	625	No. 1 crossdrift
0.88	685	
0.46	746	
2.31	806	No. 2 crossdrift
2.22	875	
2.10	944	
6.80	1013	
6.20	1081	No. 2 crossdrift
10.81	1144	
19.41	1206	
10.81	1268	
7.85	1331	
7.43	1394	No. 4 crossdrift
12.60	1494	604 ramp
8.0	1569	Fan drift
6.67	1682	No. 5 crossdrift
4.00	1742	
1.50	1802	
1.93	1862	

Table 8-4. Receive Signal Strength (Figure 8-5) (Cont).

SIGNAL STRENGTH (mv/metre)	DISTANCE (ft)	LOCATION
3.01	1922	No. 6 crossdrift
0.94	1982	
6.90	2050	
11.61	2117	
11.42	2185	
9.31	2252	
3.71	2320	
4.7	2391	
5.64	2462	
3.36	2533	
0.98	2599	
1.18	2665	
0.38	2730	
0.17	2796	E/W drainage
0.38	2877	608W

Table 8-5. Receive Signal Strength (Perpendicular to Coax) (Figure 8-6).

SIGNAL STRENGTH (mv/metre)	DISTANCE (ft) (Cert 875)	LOCATION
0.428	0	East drainage
0.099	50	East drainage
0.028	75	East drainage
0.014	100	East drainage
0.015	125	East drainage
0.011	150	East drainage

Table 8-6. Receive Signal Strength (Perpendicular to Coax) (Figure 8-7).

SIGNAL STRENGTH (mv/metre)	DISTANCE (ft) (Radiax RX5-1R)	LOCATION
0.395	0	609W
0.15	50	609W
0.089	75	609W
0.103	100	609W
0.061	125	609W
0.047	150	609W
0.018	175	609W
0.013	200	609W (wipe cable off)
0.367	0	609W
0.155	50	609W
0.113	75	609W
0.078	100	609W
0.025	150	609W
0.016	200	609W

Table 8-7. Receive Signal Strength Fan-Hole Drift (Figure 8-8).

SIGNAL STRENGTH (mv/metre)	DISTANCE (ft)	LOCATION
0.331	50	615E
2.209	75	615E
2.021	100	615E
1.006	125	615E
0.964	150	615E

Table 8-7. Receive Signal Strength Fan-Hole Drift (Figure 8-8) (Cont).

SIGNAL STRENGTH (mv/metre)	DISTANCE (ft) (Cert 875)	LOCATION
0.884	175	615E
0.714	200	615E
0.254	225	615E
0.296	250	615E
0.254	275	615E
0.103	300	615E
0.122	325	615E

Table 8-8. Receive Signal Strength (Figure 8-9).

SIGNAL STRENGTH (mv/metre)	DISTANCE (ft)	LOCATION
11.22	0	Shaft B
1.00	160	Air door
0.63	312	Maintenance bay
1.26	520	Parking ramp
1.26	624	No. 1 crossdrift
2.00	720	New parking
8.91	800	No. 2 crossdrift
6.31	944	
7.94	1084	No. 3 crossdrift
7.94	1244	
7.94	1408	No. 4 crossdrift
5.62	1520	604 ramp

Table 8-8. Receive Signal Strength (Figure 8-9) (Cont).

SIGNAL STRENGTH (mv/metre)	DISTANCE (ft)	LOCATION
28.18	1652	No. 5 crossdrift
12.59	1744	Conveyor drift
2.82	1860	
1.78	2012	No. 6 crossdrift
8.91	2120	
15.85	2240	No. 7 crossdrift
7.94	2424	
3.98	2496	
2.51	2576	Crusher access
2.00	2652	Crusher ramp
0.79	2752	
0.40	2872	E/W drainage
2.24	2960	608-609 split

Table 8-9. Transmit Signal Strength (Portable) (Figure 8-10).

SIGNAL STRENGTH (μ v)	DISTANCE (ft)	LOCATION
77.5	0	4U skip console
158.1	80	Air door
38.0	140	
77.5	200	Oil pump
108.0	280	Shop office
221.0	415	Ambulance
180.0	470	

Table 8-9. Transmit Signal Strength (Portable) (Figure 8-10) (Cont).

SIGNAL STRENGTH (μv)	DISTANCE (ft)	LOCATION
113.0	640	No. 1 crossdrift
148.0	725	
460.0	800	No. 2 crossdrift
170.0	900	
380.0	1105	No. 3 crossdrift
245.0	1210	
460.0	1430	No. 4 crossdrift
380.0	1540	604 ramp
560.0	1600	
1000.0	1680	No. 5 crossdrift
1201.0	1710	
878.0	1745	Conveyor drift
400.0	1780	
370.0	1820	
480.0	1860	
341.0	1900	
459.0	1940	
320.0	1975	
645.0	2015	No. 6 crossdrift
500.0	2055	
2039.0	2125	
885.0	2195	
1423.0	2265	
780.0	2335	No. 7 crossdrift

Table 8-9. Transmit Signal Strength (Portable) (Figure 8-10) (Cont).

SIGNAL STRENGTH (μv)	DISTANCE (ft)	LOCATION
790.0	2395	
822.0	2465	
411.0	2530	
241.0	2600	Crusher access
105.0	2680	
76.2	2765	
46.1	2845	E/W drainage
185.0	2925	
139.0	3005	608/609 split

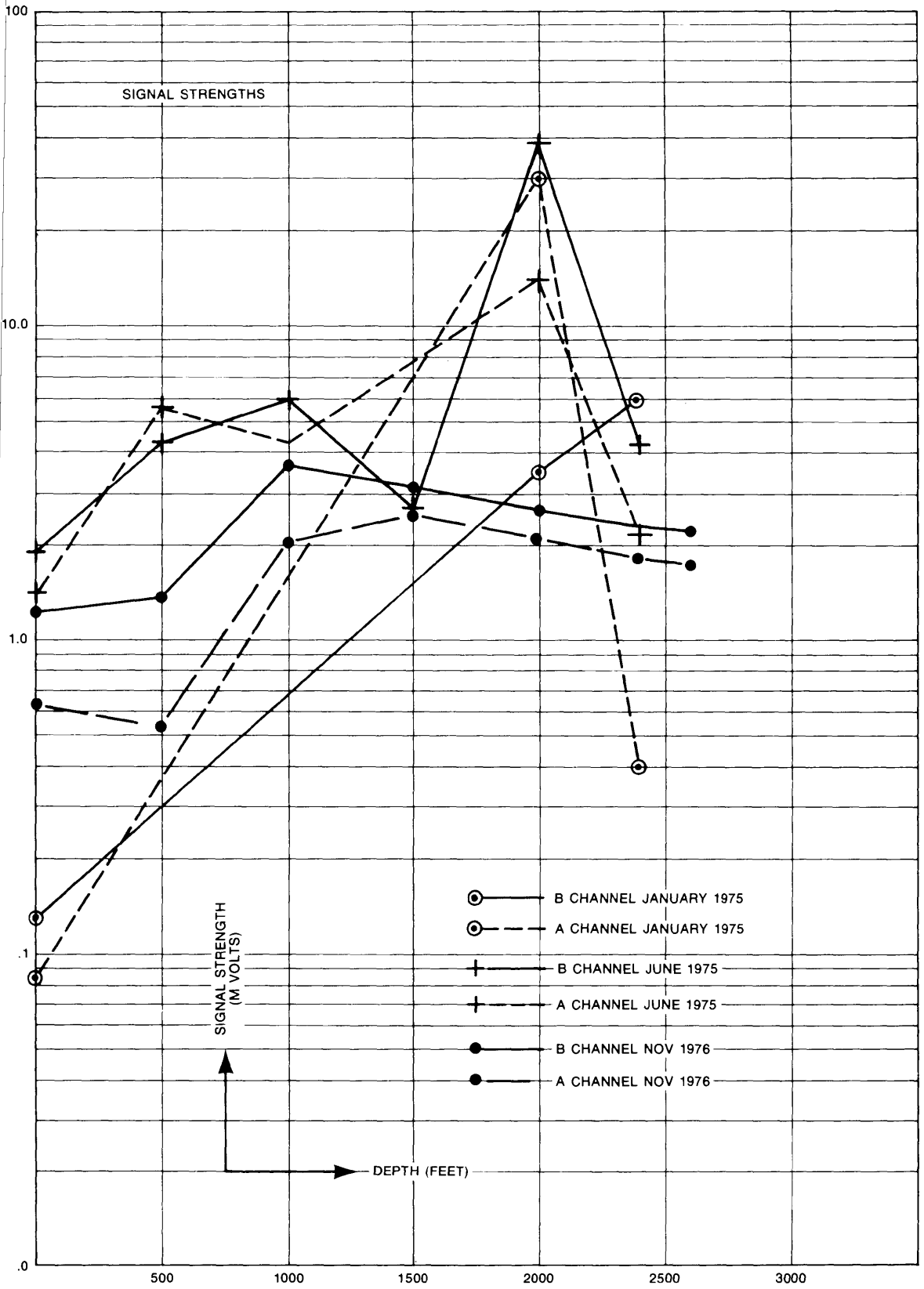

Figure 8-1. Signal Strengths at Discrete Cage Depths.

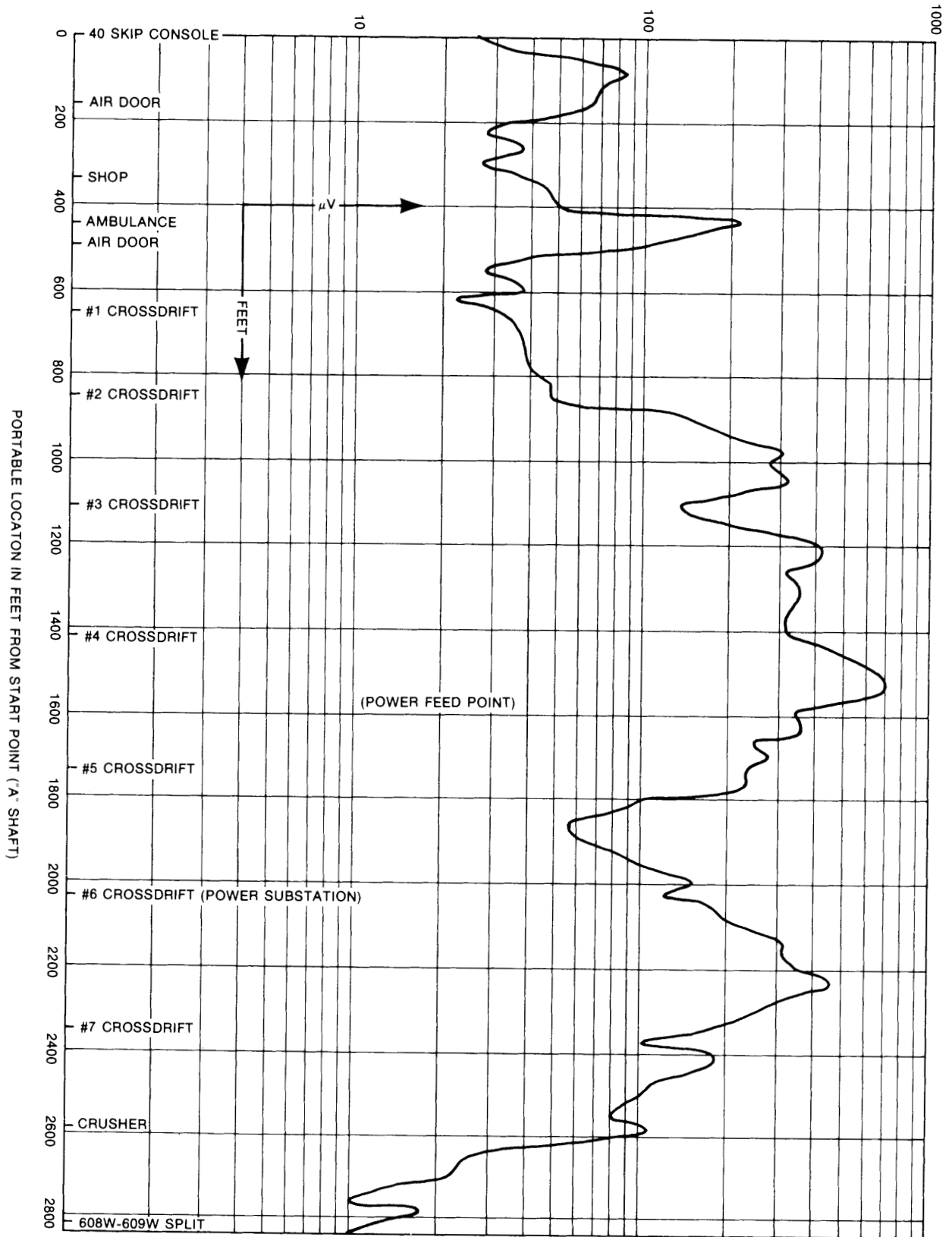

Figure 8-2. Transmit Signal Strength Mobile to Repeater B.

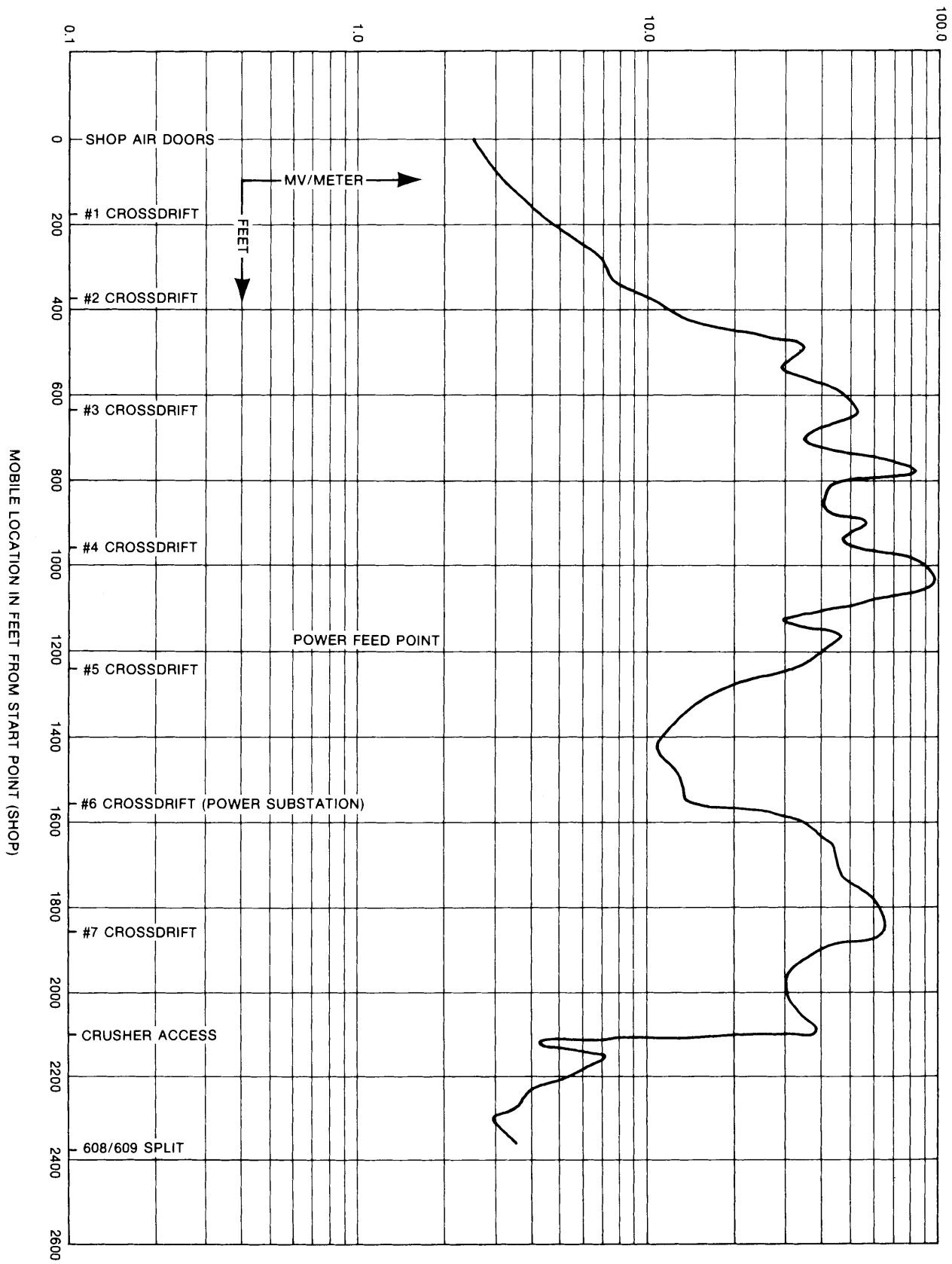

Figure 8-3. Signal Strength at Repeater B From Handheld Portable.

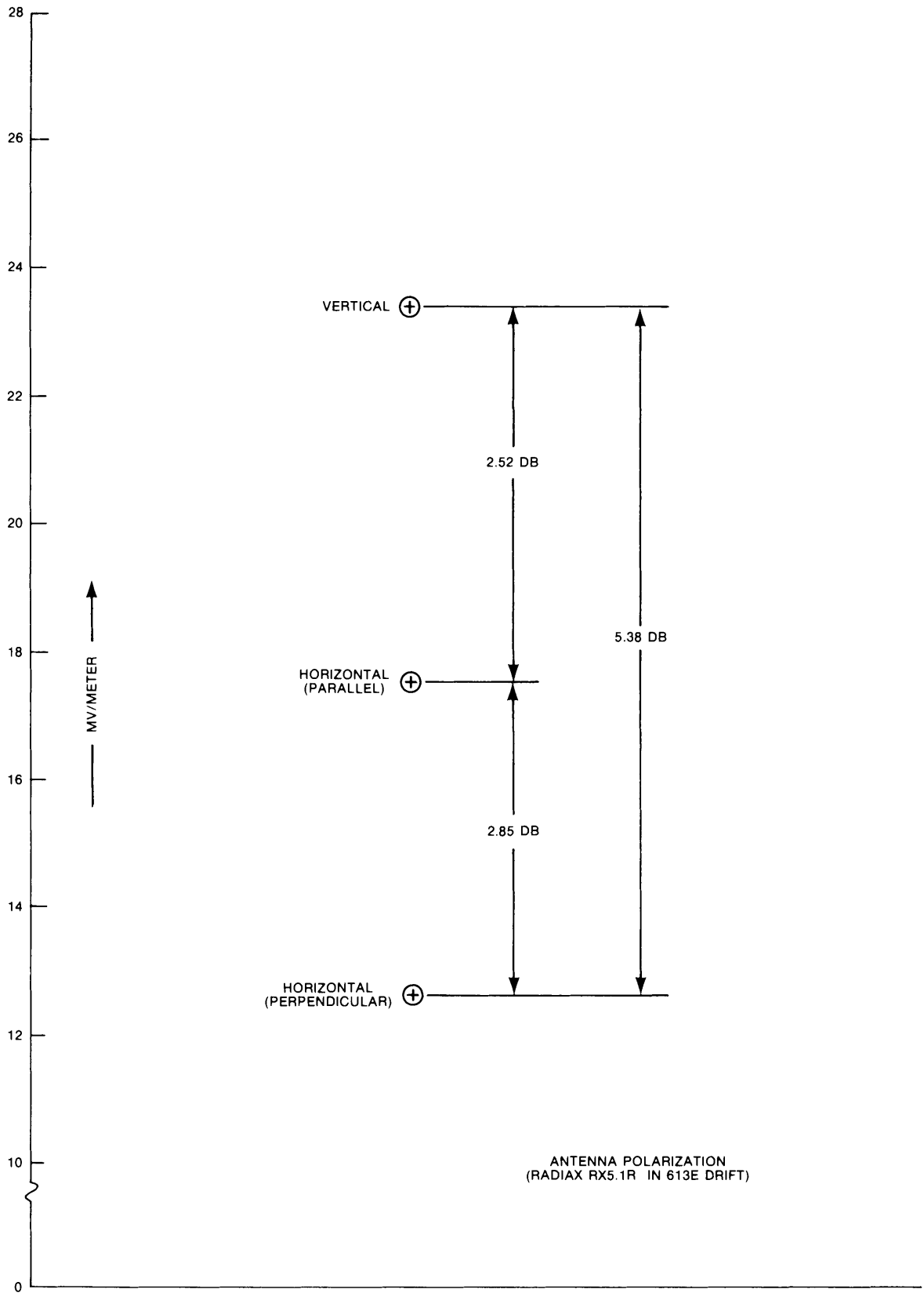

Figure 8-4. Variation in Signal Strength With Antenna Polarization.

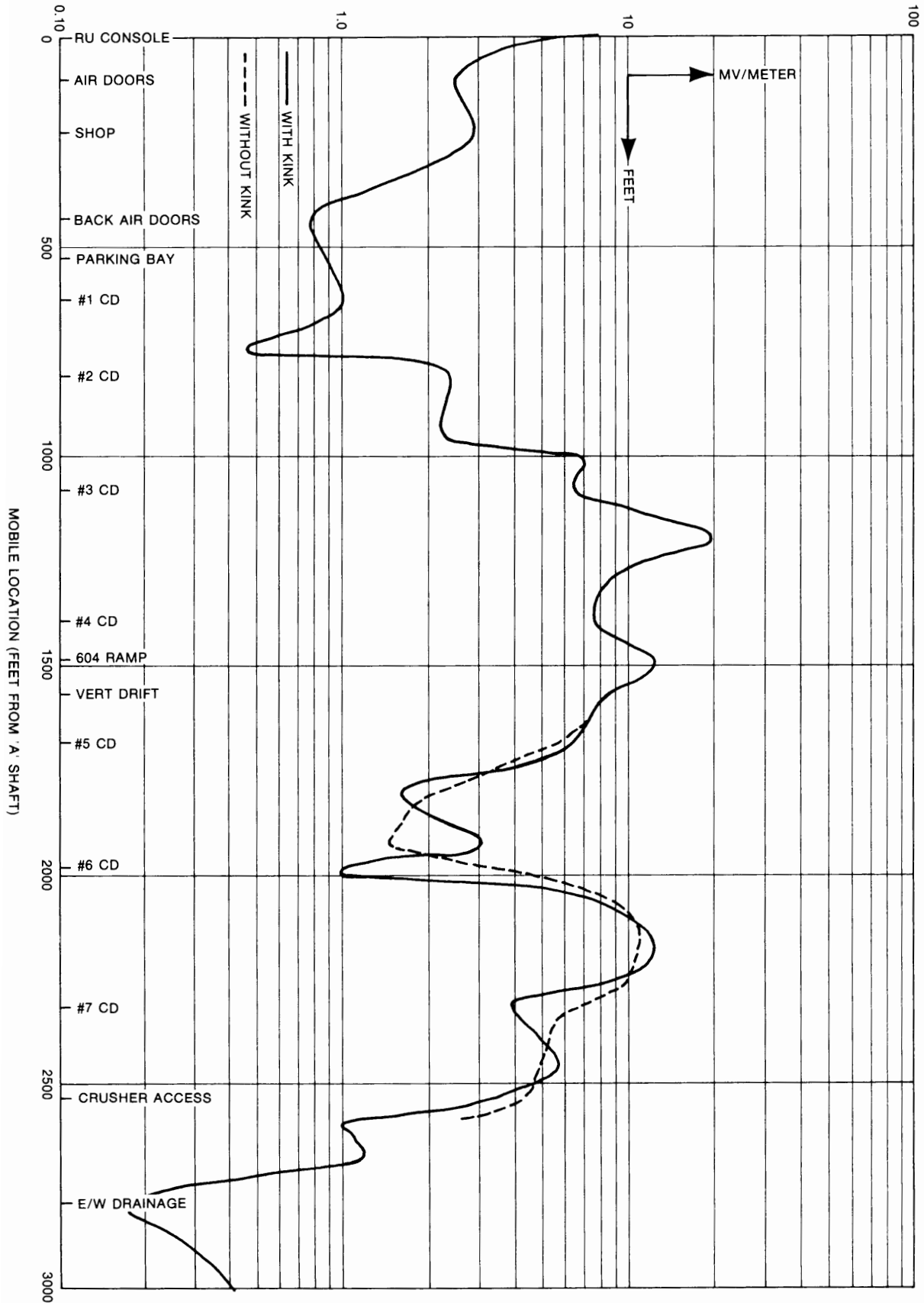

Figure 8-5. Receive Signal Strength (Main Haulage) Repeater to Portable/Mobile Zone B.

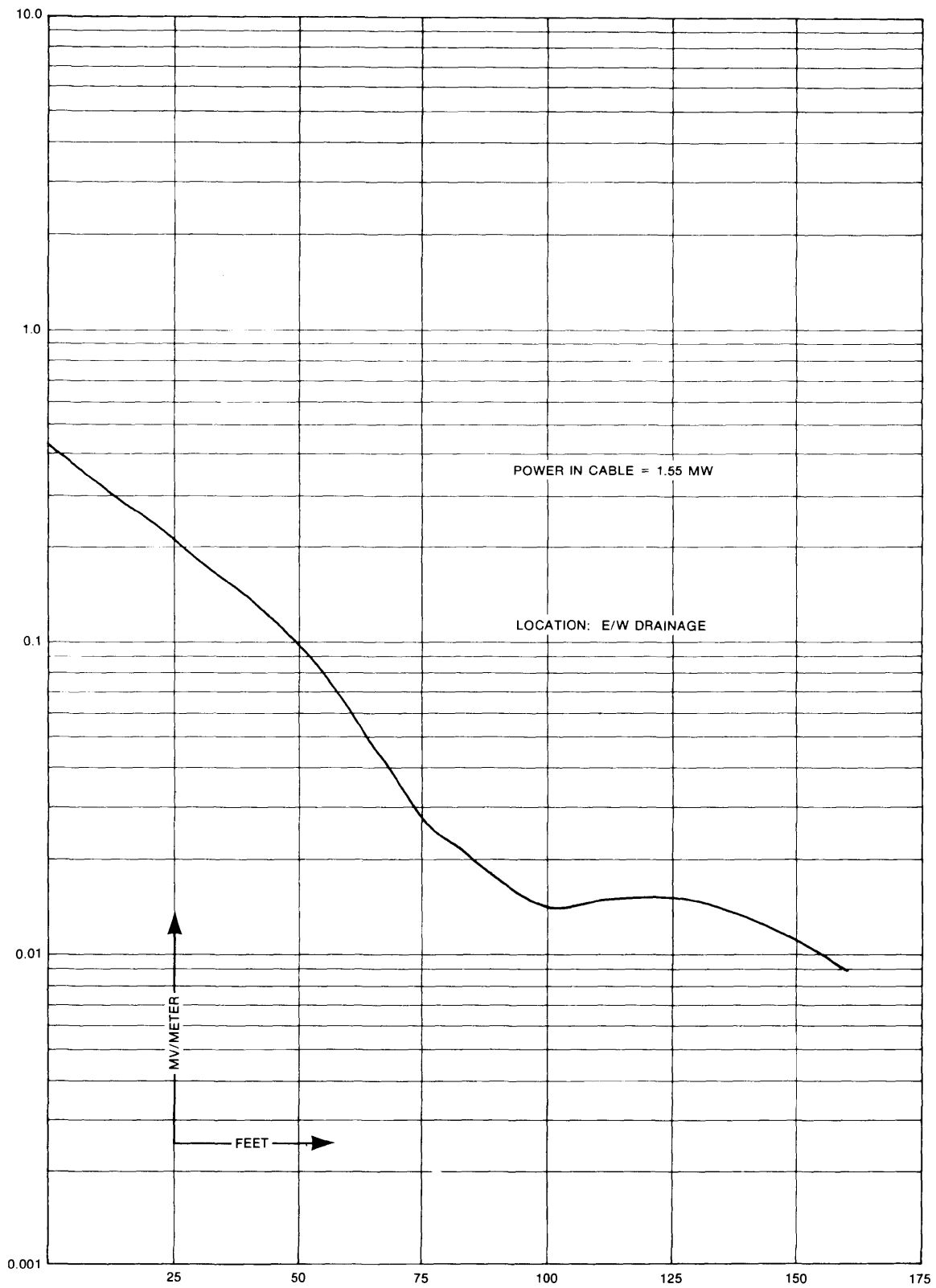

Figure 8-6. Signal Strength Perpendicular to "Leaky-Feeder" (Cert 875).

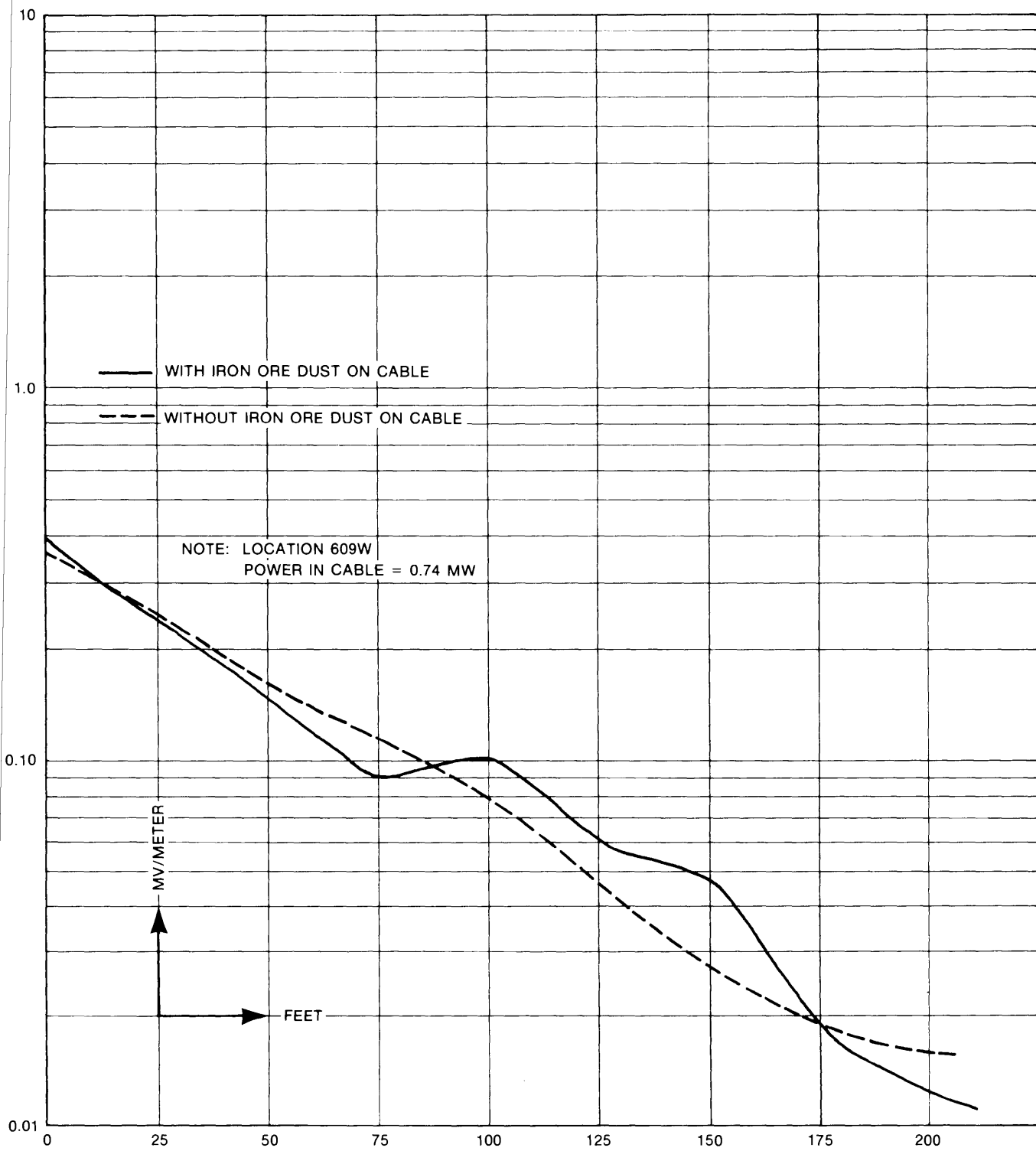

Figure 8-7. Signal Strength Perpendicular to "Leaky-Feeder" (RX5-1R).

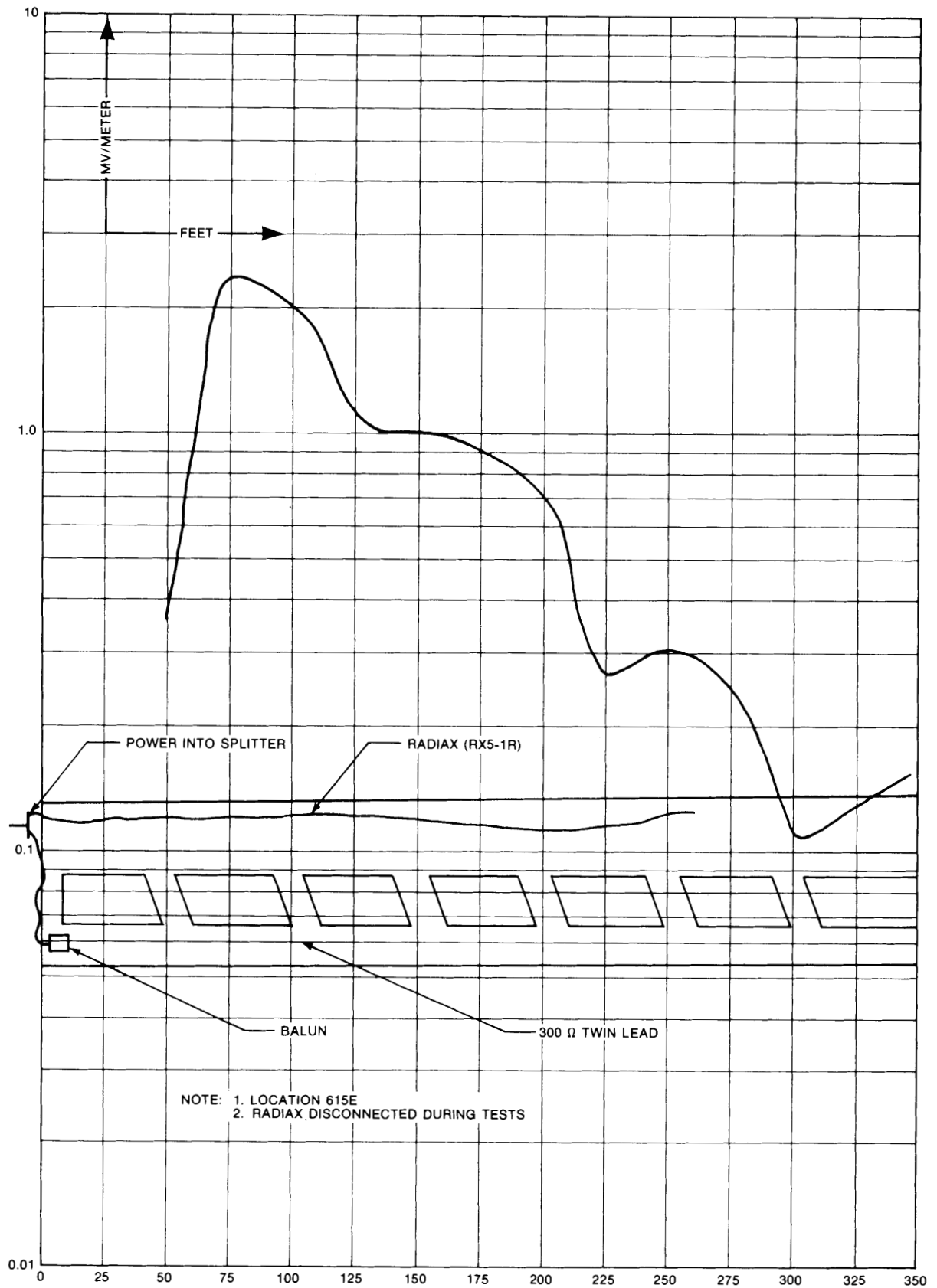

Figure 8-8. Signal Strength Parallel to Drift Containing TV 300-Ohm Twin Lead.

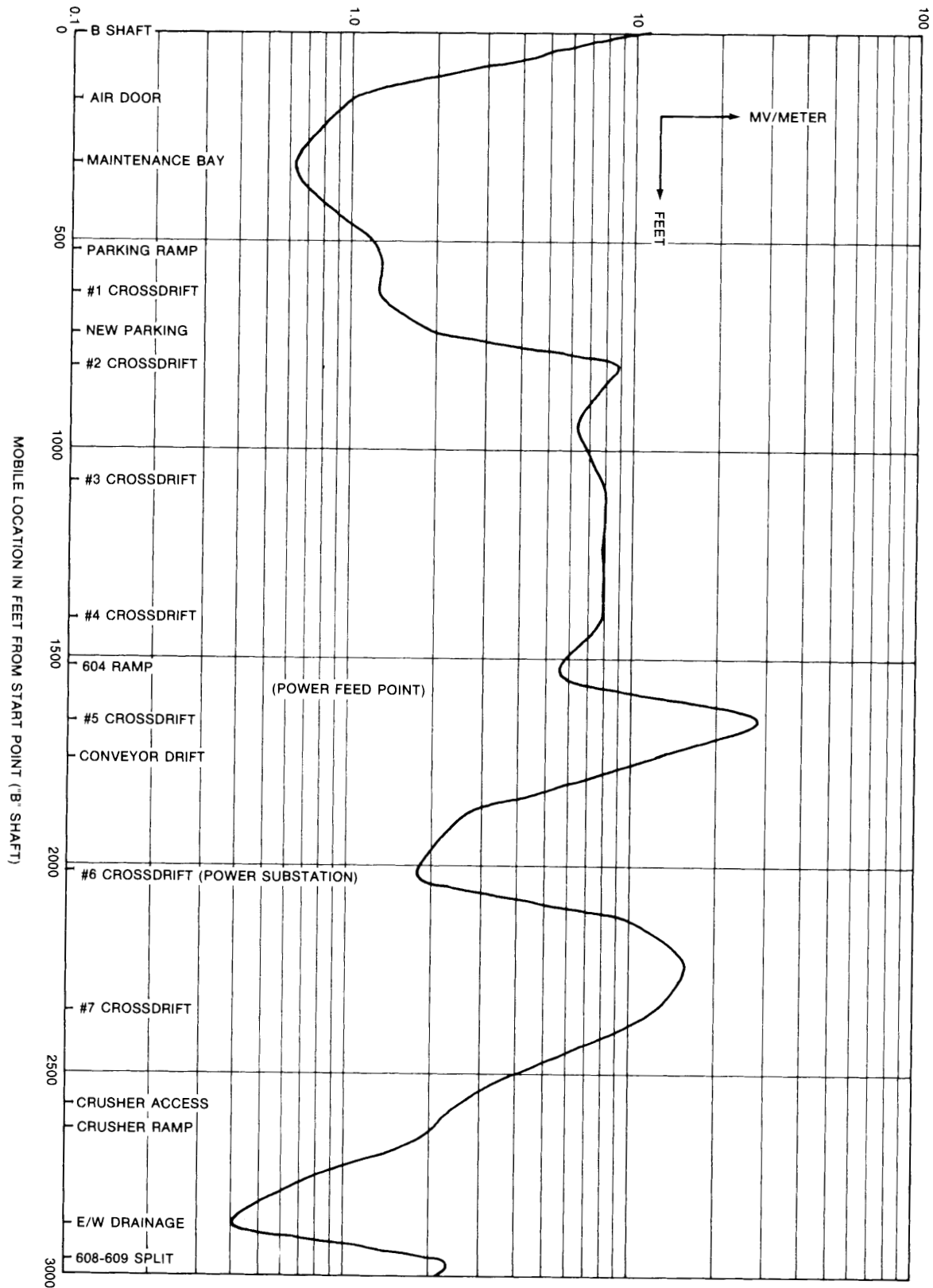

Figure 8-9. Receive Signal Strength (Main Haulage) Repeater to Portable/Mobile Zone B.

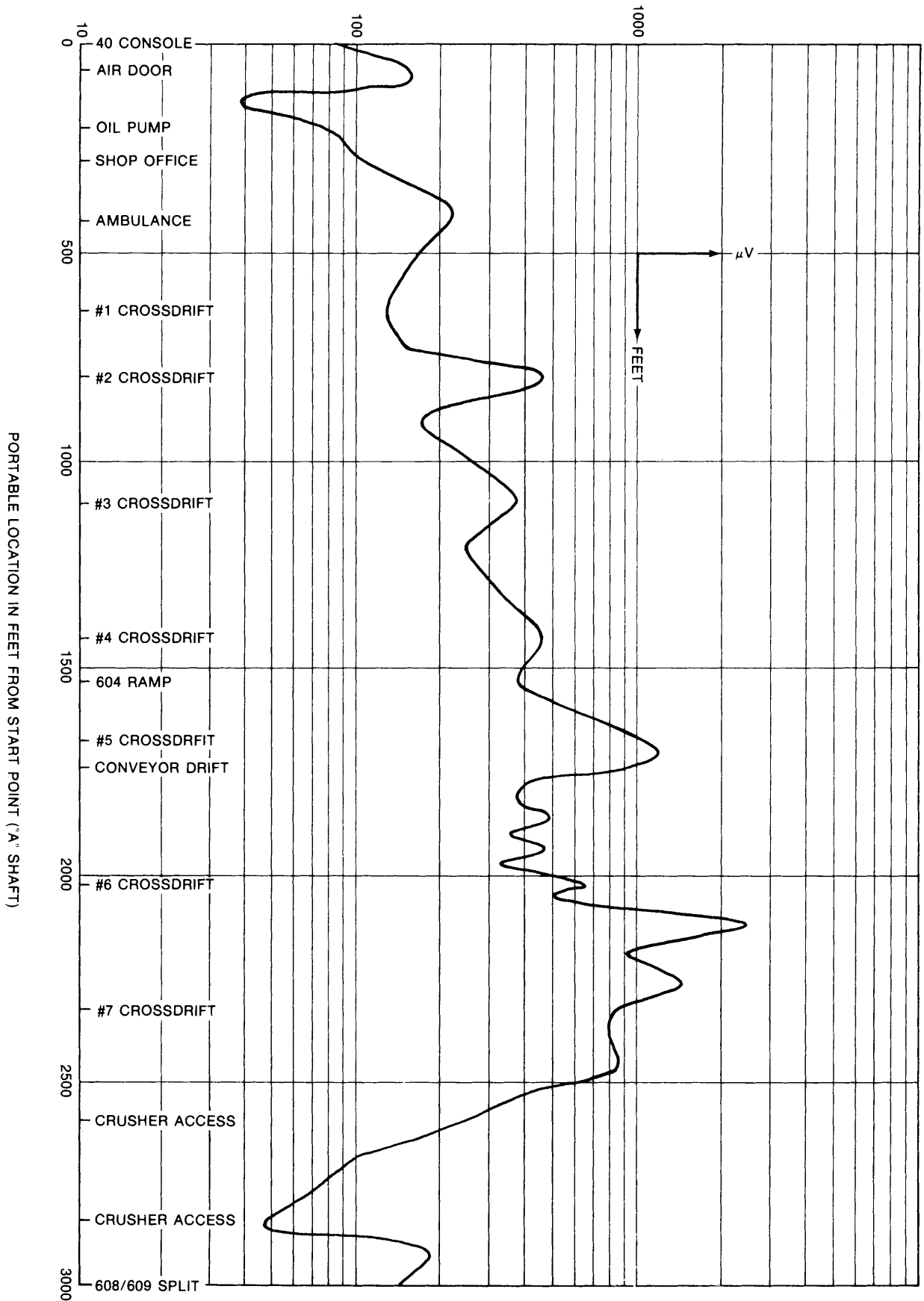

Figure 8-10. Transmit Signal Strength (Main Haulage) Portable to Repeater B.

9.0 RF "LEAKY-FEEDER" COMMUNICATIONS SYSTEM DESIGN

As was reviewed in Section II, paragraph 4.0 of this report, it was determined that an integrated "leaky-feeder" communication system would fulfill the operational requirements necessary at the Grace Mine. The decision to use 7/8-inch "leaky-feeder" and the selection of equipments are explained in these paragraphs.

9.1 Cabling Selection

Preliminary investigation at the onset of the program had revealed that two cable manufacturers marketed "leaky-feeder" cable in the United States: The Andrew Corporation, and Times Wire and Cable Company. The Andrews cable (Radiax) is an adaptation of Andrew's Heliac coaxial cable that has a spirally corrugated shield. Holes are formed in the shield by planing off the high ridges of the shield part way around the cable. The holes create the "leaky-feeder" effect and hole size determines the operating characteristics of the cable. The Times cable (Cert) uses a spirally wrapped shield with a space between the wraps to create the same effect.

Both cable brands are comparable in electrical operating characteristics; however, differences exist in mechanical adaptability to a mine application. The Radiax has a hollow center conductor and, because of the corrugations, is quite flexible. The Cert has a solid center conductor and a very thick sheath, and is, therefore, heavier than and not nearly as flexible as the Radiax. The Radiax, being an adaptation of an existing Andrews product (Heliac), is supported by a full complement of available accessories; for example, made-for connectors, mounting hardware, and complementary cable sizes for jumpers. The Cert cable, because of its fairly new introduction into the United States at the beginning of this program, did not enjoy the same availability of accessories. Connectors had to be adapted from another cable type, were complicated to use, expensive, and were not easily obtainable. In addition, the Andrews cable features a type of foam dielectric that resists moisture absorption. The Times cable utilizes a foam dielectric that is highly absorbent and thus requires all cable ends or cuts to be sealed. As with all coaxial cables, moisture absorbed into the dielectric increases attenuation, degrading the performance of the system.

The lighter weight, greater flexibility, moisture-resistant dielectric, and supporting accessories of the Andrews Radiax made it the obvious choice for use at the Grace Mine. The cable would be much easier to deploy in the confines of a mine tunnel, hold up better in the high humidity, and be more conveniently installed with the made-for connectors. However, in the interest of establishing a comparison between the two cable brands, it was agreed to use both cable brands with Radiax being predominant.

With a cable brand selected, it was necessary to determine which cable size and what equipment configuration would best satisfy the requirements at the Grace Mine. Two cable sizes are available from either manufacturer: 1/2-inch and 7/8-inch. The 1/2-inch size is also available in two performance models; that is, low attenuation with high coupling loss* and high attenuation with low coupling loss. The 7/8-inch cable is only available in a model displaying low attenuation and high coupling loss characteristics. The 1/2-inch model with high attenuation and low coupling loss is intended for use where relatively short cable runs are anticipated and long distances between cable and transceivers are needed. Since the cross-sectional size of the tunnels (drifts) at the Grace Mine are 12 by 12 feet, it would not be

*Coupling loss is the average difference between signal level in the cable and the signal received by a zero-dbd gain antenna 20 feet from the cable.

necessary to have the low coupling loss to attain satisfactory communications in the main haulages. Additionally, the number of repeaters required to implement the entire mine with high attenuation/low coupling loss cable would be prohibitive.

In the interest of reducing the number of required equipments, the field was narrowed to the choice between the 1/2-inch model with low attenuation and high coupling loss and the 7/8-inch type. The cable types selected for consideration are manufactured by Andrews and are cable models RX4-1 and RX5-1, respectively, for 1/2- and 7/8-inch cable. Site surveys in the mine and interviews with mining personnel determined that 11,000 feet of "leaky-feeder" would be required to fully implement the mine with communications. This 11,000 feet represented the need based on mining plans for two years following the initial site surveys in the spring of 1974. Later surveys confirmed that 11,000 feet of cable would be sufficient for needs through 1980.

Using the 11,000 feet of "leaky-feeder" line and the necessary cable interconnect hardware required to implement the mine, it can be shown that multiple repeater stations would be required for RX4-1 or RX5-1 applications. The following calculations will verify the repeater requirements.

NOTE

The operational concept of a repeater-type system is assumed to be known by the reader and is therefore omitted from these paragraphs. A detailed description of the operation of the Grace Mine system is, however, included in Section II, paragraph 5.0 of this report.

Since a chain is no stronger than its weakest link, let us review repeater and cable requirements with the weak link of a "leaky-feeder" system; that is, signal path from a portable transceiver (man-carried, lower unit) to a repeater (high power, stationary unit) located on the "leaky-feeder" line. The following calculation determines available signal losses assuming the use of a repeater-type system and portable transceivers.

"Leaky-Feeder" Cable Range Calculation

Receiver sensitivity, 0.5 μv (typical for uhf receivers)	-113 dbm
Transmitter power, 4 watts (portable)..... (typical for uhf portable transceivers)	+36 dbm

Total Transceiver Range.....	149 db
Cable coupling loss at 450 MHz (Per vendor specifications for RX4-1 or RX5-1)	-85 db
System use factor (reserve capacity for possible degradation in cable or equipment performance)	-20 db

Signal range between portable transceiver and repeater	<u>44 db</u>

Hence, up to 44 db of signal loss can occur between a portable transceiver (within 20 feet of the "leaky-feeder") and a repeater attached directly to the "leaky-feeder" line. The 44 db represents a loss that can be additional loss through air (in excess of the 20 feet compensated for by the coupling loss figure) or cable, connector, and signal splitter attenuation. In the case of the Grace Mine system, the loss for main haulages will be limited to cable and signal splitter attenuations. Connector loss is approximately 0.1 db per unit and will not be a factor in these rough calculations.

Signal splitters are used to divide the signal in the cable into two equal levels for distribution via separate paths, adding approximately 3.5 db of loss to both signal paths. Cable attenuation is the relation of resistance to a signal propagating through the cable. Vendor literature states that RX4-1 cable has an attenuation of 2.1 db/100 feet at 450 MHz,* while RX5-1 cable has an attenuation of 1.2 db/100 feet at this same frequency. Humidity, temperature, and time have an adverse effect on coaxial cable, causing the attenuation to rise. For our calculations, we added 10 percent to each figure to compensate for these increases in attenuation giving 2.3 db/100 feet and 1.3 db/100 feet for RX4-1 and RX5-1 respectively.

As shown in figure 9-1, if a repeater is located at the end of a "leaky-feeder" line (assuming no splitters), the 44 db of available loss provides usable communications for a distance of 1913 feet along a RX4-1 cable or 3385 feet along a RX5-1 cable. Locate the repeater in the center (figure 9-1) with one splitter to "feed" signal both directions and the distances become 1761 feet each way or a total of 3522 feet for RX4-1 and 3115 feet each way, or a total of 6230 feet for RX5-1. It would therefore be possible to locate repeaters every 7044 feet using RX4-1, or 12,460 feet using RX5-1 (twice individual ranges yield distance between repeaters).

In practicality, the number of signal splitters, expected reliability, and cable terminations must be carefully considered to ensure adequate signal down all paths. Figure 9-2 provides a model of the cable runs required for the Grace Mine based on site survey results. The indicated cable locations would have provided communications through 1976 per surveys conducted in the spring of 1974; however, these cable runs were amended to reflect current mining needs and do not affect equipment or cable selections.

Applying the 44 db of available loss to the cable model of figure 9-2, we can verify that repeaters would be required at points A, B, and C for an RX4-1 installation and at point D for an RX5-1 installation. Verification is accomplished by first starting at the extreme ends of the model (CE9, CE4, and CE7), and adding up loss values on paths directed toward the center of the model. The cable ends are the farthest points where communications are desired and the loss values include indicated cable and splitter attenuations. For an RX4-1 installation, A, B, and C are points 44 dB from the cable ends at CE9, CE4, and CE7 respectively. For an RX5-1 installation, point D is the center of the system and is less than 44 db from any cable end.

These points were determined as follows:

a. Point A (RX4-1)

The cable loss between CE9 and S1 is 44.9 db; therefore, a repeater must be located 39 feet (0.9 db) before S1. However, since a splitter would be required at each repeater site

*Uhf frequency selected for system calculations. The exact frequency used would depend on FCC assignments and would be close to 450 MHz.

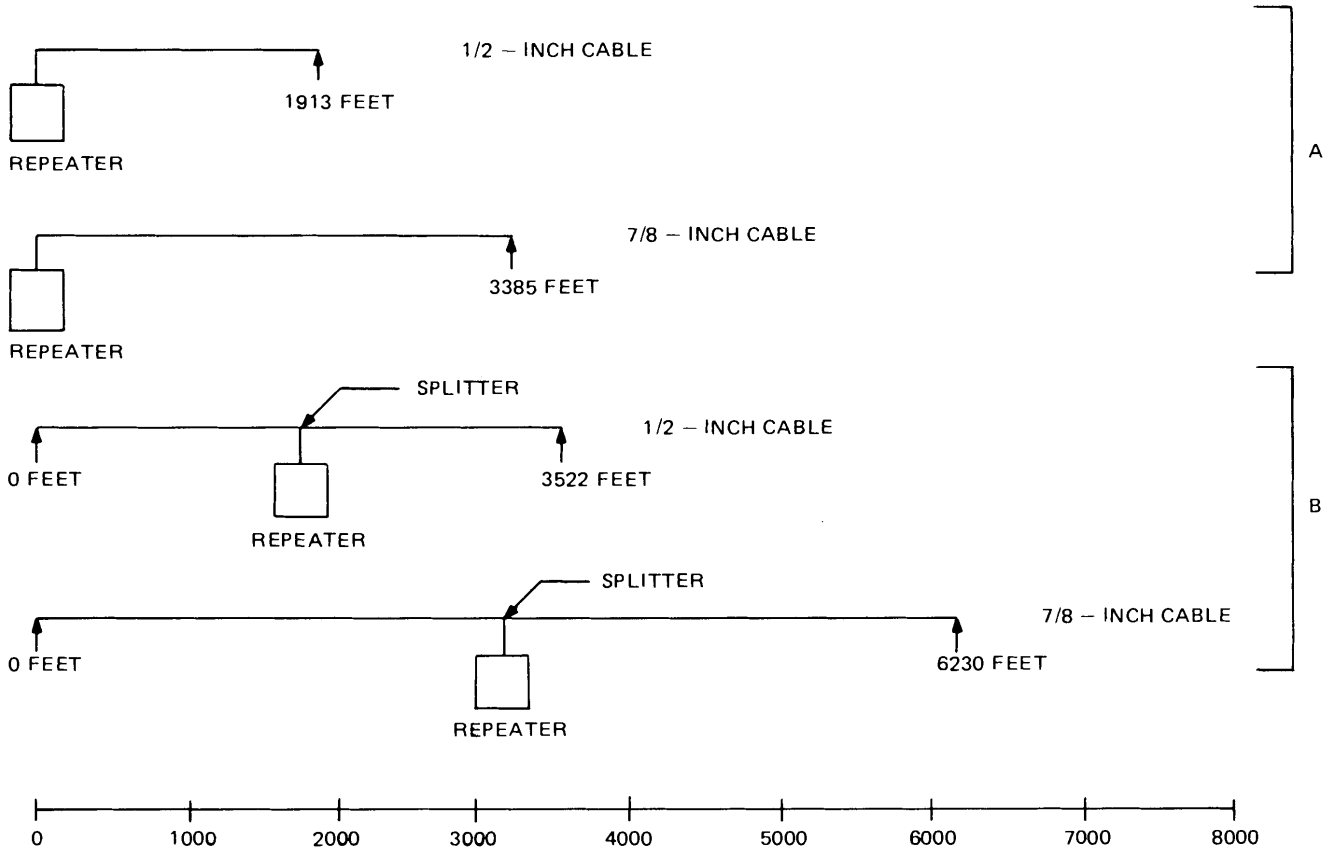

TP5-6726-011

Figure 9-1. Usable Cable Distances.

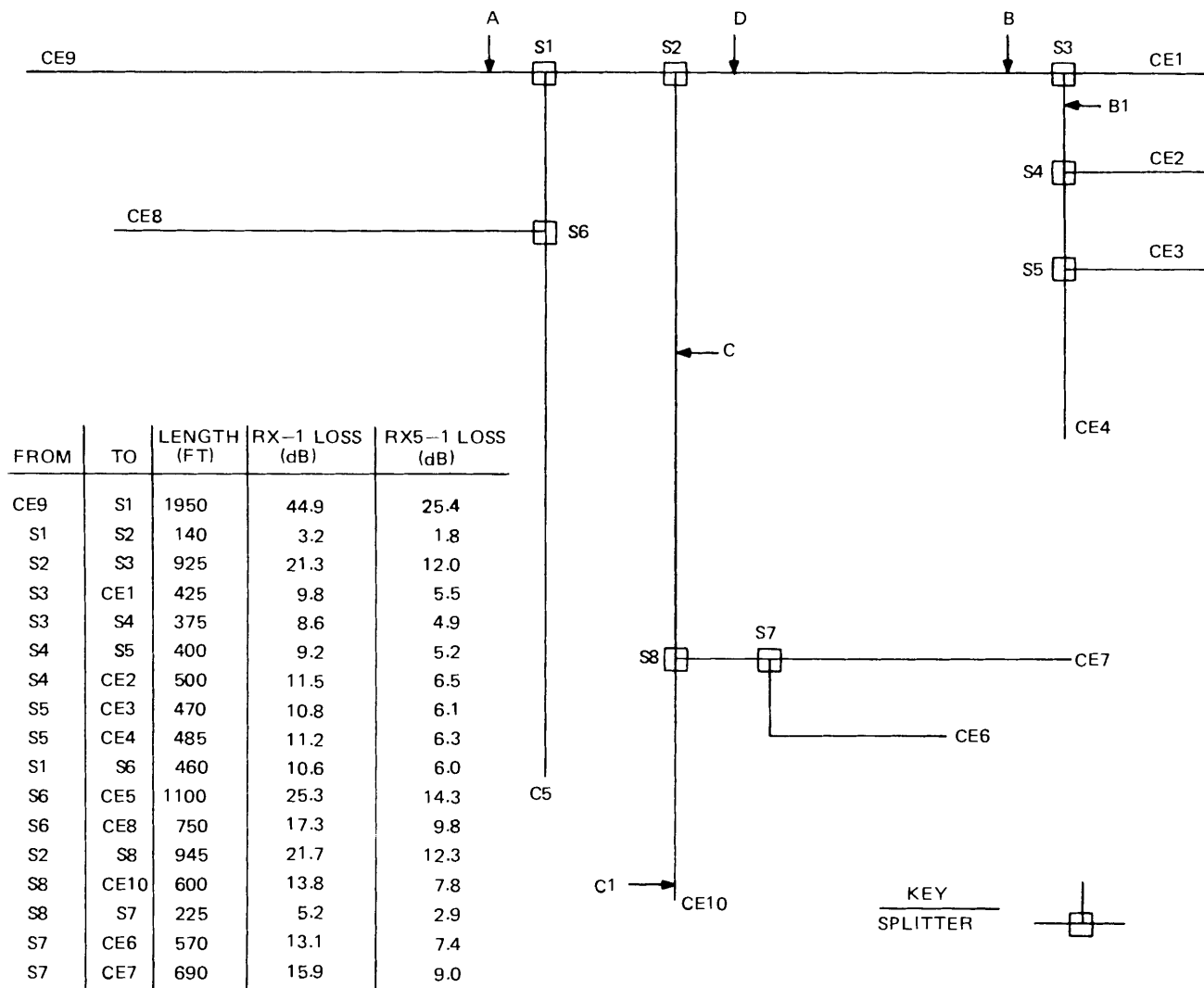

TP5-6727-011

Figure 9-2. Cable Distribution Model.

to direct the signal along both cable directions, one must also consider an additional 3.5 db loss at each repeater. Point A must move 3.5 db (152 feet) closer to CE9 in order to provide the necessary signal at that point.

b. Point B (RX4-1)

The cable loss between CE4 and S5 is 11.2 db while the loss between CE3 and S5 is 10.8 db. Minimum signal is required at all cable ends, so one must use the larger CE4 to S5 loss. In a like manner, the CE1 or CE2 to S3 losses are less than the CE4 to S3 loss, so the larger loss is selected for our calculations. Total loss through S3 from CE4 would be as follows:

CE-S5	11.2 db
S5	3.5 db
S5-S4	9.2 db
S4	3.5 db
S4-S3	8.6 db
S3	<u>3.5 db</u>
Total	<u>39.5 db</u>

Allowing for the 3.5 db required for a splitter at the repeater site raises the total to 43 db. A second repeater would be required on the S3 to S2 line, approximately 1.0 db (43 feet) from S3.

c. Point C (RX4-1)

The loss between CE7 and S7 is greater than the loss between CE6 and S7, 15.9 db versus 13.1 db, while the loss between CE10 and S8 is less than the loss between CE7 and S8. The CE7 to S8 path is the path of greatest loss and is as follows:

CE7-S7	15.9 db
S7	3.5 db
S7-S8	5.2 db
S8	<u>3.5 db</u>
Total	<u>28.1 db</u>

The 3.5 db splitter loss for the repeater raises the total to 31.6 db. A third repeater would be required at point C on the S8 to S2 line 12.4 db (539 feet) from S8.

d. Point D (RX5-1)

Considering the same paths as used to determine repeater sites A, B, and C for an RX4-1 installation indicates that only a single repeater would be required for an RX5-1 installation. The calculations have been omitted since they are similar to the RX4-1 calculations. Point D, located on the S2 to S3 line 6.5 db (283 feet) from S2, is the model center from which the loss to any cable end is less than 44 db.

The indicated repeater sites of A, B, and C for an RX4-1 installation or point D for an RX5-1 installation would provide adequate communications throughout the mine complex to all areas containing the "leaky-feeder". Since the calculations were started at cable ends and proceeded to the model center, the areas of minimum signal would occur near repeater sites.

In a railroad tunnel, or in the main haulage areas of a mine, where coverage is required only near the "leaky-feeder", the minimum signal at cable ends would not present a problem. At the Grace Mine, however, new mine development or the fan-hole drill operators could be at the cable ends and could be beyond the 20 feet allowed for in the loss calculations performed above. It is therefore desirable to compensate for additional lateral and off-the-cable end losses in new development and fan-hole drill areas, ensuring adequate coverage during normal mining operations. The signal reserve is boosted in these critical areas by either decreasing the coupling loss to or increasing the signal level available in the cable.

Coupling loss is reduced by using a "leaky-feeder" cable with lower coupling loss and by attaching antennas to the cable ends. The lower coupling loss cable will increase the available signal by approximately 20 to 30 db* while suitable antennas have a near 0 db loss and will increase the signal by an amount equivalent to the cable coupling loss (approximately 85 db for RX4-1 or RX5-1 cable). Signal level in the cable can be increased by several methods, including increasing portable transceiver power output, increasing repeater receive sensitivity, or physically moving the repeater closer to areas requiring more signal. Portable transceivers are limited to 4 to 5 watts of rf power output by physical size and battery requirements. Repeater receive sensitivities are limited to approximately 0.5 μ v because of noise interference. The only remaining alternative for raising signal levels would be the relocation of repeater sites to positions closer to fan-hole drill and new development areas. The relocation of repeaters would also be necessary to compensate for the additional attenuation if the lower coupling loss cable were used in these areas. In our example, 88 db of signal loss between repeater sites is possible.

Since the repeaters in the RX4-1 example are separated by only 41.88, 30.80, and 30.93 db, respectively, for A to B, B to C, and C to A, it is possible to move the repeaters closer to the fan-hole drill and new development areas without degrading system performance. The greater distances between repeater sites is also desirable to reduce the interference created when transceivers are simultaneously within the range of more than one repeater.

The fan-hole drill areas of the mine are near CE2, CE3, CE4, CE6, and CE7, while new development is directed towards the CE10 area. All other areas are limited to maintenance and haulage usage.

In the RX4-1 installation example, repeaters shown at points B and C on figure 9-2 are relocated to points B1 and C1 to increase signal coverage in the fan-hole drill and new development areas. Point A can remain as calculated, since the CE5, CE8, and CE9 areas do not require communications beyond the cable ends.

Using RX5-1, a second repeater site is established at the same C1 point identified for the RX4-1 installation. The C1 point for an RX5-1 installation provides the signal level necessary for new development in the CE10 area, as well as allowing the repeater at site D to more adequately cover the fan-hole drill areas at CE2, CE3, and CE4.

Figure 9-3 shows the proposed RX4-1 installation with repeaters at points A, B, and C and antennas at cable ends. In addition to increasing the communication range at a cable end, an antenna also properly terminates the cable in a 50-ohm load, thereby reducing vswr and signal reflections in the "leaky-feeder". As can be seen by figure 9-3, the model has been divided into three distinct repeater areas (or zones), each with a repeater and associated

*Coupling loss for Radiax RX4-3A at 450 MHz is 61 db and Cert 500 at 450 MHz is 60 db.

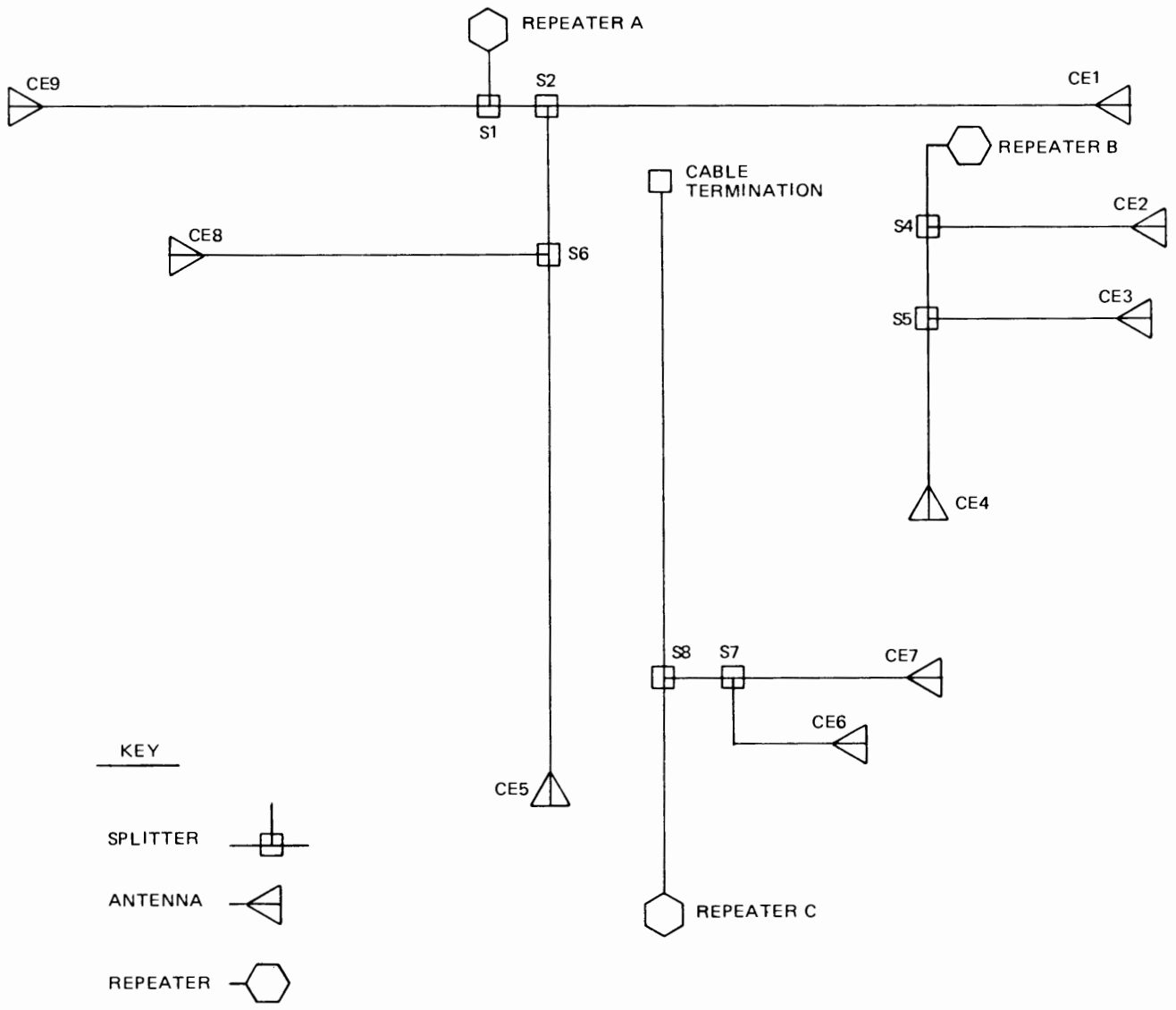

TP5-6728-011

Figure 9-3. RX4-1 (1/2-Inch) Basic Cable Distribution Model.

runs of "leaky-feeder". The area around repeater A is zone A and likewise for the other two zones. Zone A is used primarily for haulage and roving miner type communications (that is, maintenance vehicle/ambulance dispatch or supervisory personnel location). Zone B is an area of secondary production development that requires maintenance vehicle and fan-hole drill operator communications. Zone C is the section of the mine devoted to primary production development, requiring the same communications as zone B but on a larger scale.

Separation of the system into zones not only reduces possible interference between repeaters, but also increases available signal in critical areas, allows greater expansion of the system in new development areas, and simplifies repeater interconnections. It is assumed that the repeaters will have to be interconnected to enable communication between zones. The exact method of interconnection is not important to the discussion of determining cable size, however, and will be discussed later in these paragraphs. Repeater zones are, therefore, shown as not being connected. Assuming the zones were connected, the separation would be 49.89, 70.8, and 57.09 db, respectively, for A to B, B to C, and C to A; greatly improved from the previous calculations.

Figure 9-4 shows the proposed RX5-1 installation with repeaters at points D and E and antennas at cable ends. Like the RX4-1 installation, the RX5-1 example is divided into zones, each with a repeater and associated runs of "leaky-feeder" cable. Zone D is comprised of repeater D and the "leaky-feeder" runs associated with zones A and B of the RX4-1 example. Zone E consists of repeater E and the same "leaky-feeder" used with zone C of the RX4-1 example. Zone separations provide the same advantages as outlined for the RX4-1 installation. Repeater E provides communications coverage for new production areas and allows adequate signal reserve for future expansion while repeater D provides coverage for maintenance and secondary production areas. It was felt that the use of antennas at cable ends and the available signal reserve at repeater D would be adequate for communications coverage at CE2, CE3, and CE4.

The two proposed cable configurations were compared as to cost, physical strength, long-term reliability, and system complexity. The results of this comparison are as follows:

a. Cost*

	<u>RX4-1</u>	<u>RX5-1</u>
Cable	\$19,250.00	\$29,150.00
Signal splitters	700.00	800.00
Connectors	235.00	875.00
Repeaters	<u>9,000.00</u>	<u>6,000.00</u>
Total	\$29,185.00	\$36,825.00

*Costs are approximate based on 1974 figures. It can be expected that current prices are higher; however, relative proportion should be the same.

With all other factors considered equal, there is an approximate cost differential of \$7,640.00 between the two configurations, with the RX5-1 system the more expensive. It was expected that the RX5-1, being larger in diameter, more ridged, and heavier,

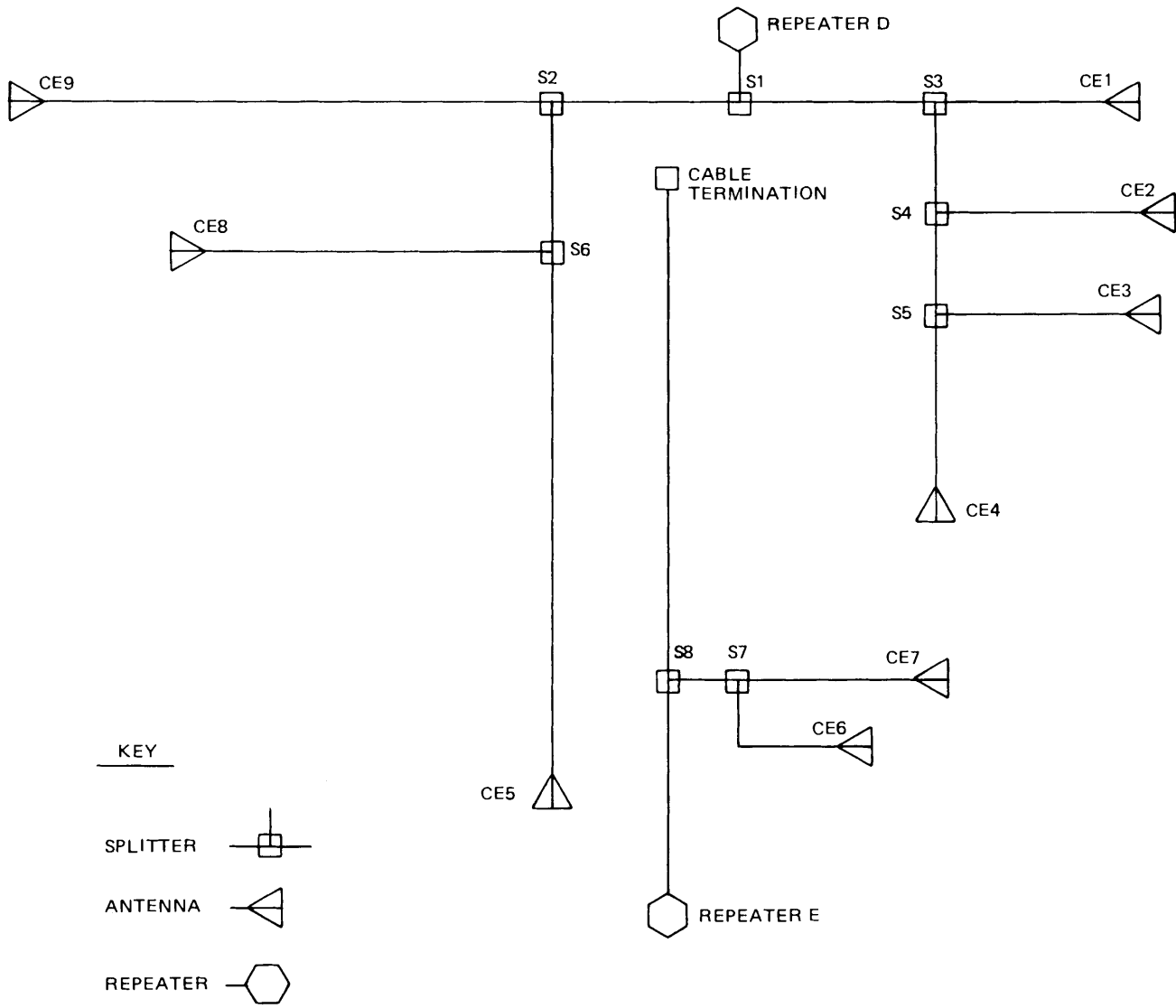

TP5-6729-011

Figure 9-4. RX5-1 (7/8-Inch) Cable Distribution Model.

would also take longer to install and require the use of flexible jumper cables between the RX5-1 and cable equipments (splitters, repeaters, or antennas). These factors will add to final system costs and should be considered for any installation. For the Grace Mine, the additional factors will be temporarily ignored.

b. Physical Strength

RX5-1 has a tensile strength of over 700 pounds and a crush strength greater than 120 pounds per linear inch. RX4-1, with approximately one-third the cross-sectional area, has about half the tensile strength but has a slightly higher crush strength. The high tensile strength of both cable sizes is achieved by bonding the foam dielectric to the inner conductor and then corrugating the outer conductor into the foam. This "locking" of the cable together also precludes differential expansion within the cable. Standard connectors available from Andrews are used on both RX4-1 and RX5-1. These connectors have a patented collet for gripping the helically corrugated outer conductor. The RX5-1 units also utilize a self-tapping pin for attaching to the inner conductor so that soldering is not required. The connectors used on RX5-1 have been pulloff tested in excess of 250 pounds. No data was available for pulloff strength of RX4-1 connectors, but because of the shallower corrugations, somewhat less than 250 pounds was expected.

c. Long-Term Reliability

The physical strength of the RX5-1 cable was expected to give longer service in the harsh environment of the Grace Mine. The larger cable would not be as susceptible to damage inflicted by mine haulage vehicles. The fewer repeaters associated with an RX5-1 installation would also decrease expected equipment maintenance. Since no quantitative figures existed comparing the two cables, experience was used as the guide for determining that RX5-1 would give a more reliable installation.

d. Complexity

It is obvious that two repeater stations would require less sophistication to implement and interconnect than would three.

Recapping the comparison between the two cable sizes concludes that RX4-1 is superior to RX5-1 only from a cost standpoint. The greater physical strength, expected long-term reliability, and reduced complexity of an RX5-1 installation tend to outweigh the cost savings of an RX4-1 installation. Maximum strength and reliability in conjunction with a system complexity within the capabilities of the mine personnel are prime considerations for a mine communications system. It was agreed that an \$7,640.00 cost differential was not sufficient to offset the advantages expected of a 7/8-inch cable installation. It was proposed that the system therefore be implemented with two repeater stations using Andrews Radiax RX5-1R* "leaky-feeder" cable for main haulages. As described earlier, Times CERT 875 cable was recommended for location in selected sites to be used as a comparison of operation for the two cable brands. Andrews Radiax RX4-3R high attenuation/low coupling loss "leaky-feeder" was recommended for use in a new development area to demonstrate the effects of the low coupling loss cable. Antennas were proposed for all cable ends to properly terminate the cable and to increase communication coverage in these areas. Preliminary cable layout would be as displayed in figure 9-4.

*The R designation of Radiax indicates usage of a fire-retardant cable jacket; recommended when maximum safety is desired.

9.2 System Design

General communication requirements, identified in paragraph 3.0, had been determined via site surveys and personnel interviews, and are as follows:

- a. Dispatch and communication for the underground vehicles (ambulance)
- b. Communication with fan-hole drill operators
- c. Paging or call alert of supervisory personnel

These requirements were sufficient to identify the need for an integrated haulage communications system employing "leaky-feeder" technology at uhf frequencies. Subsequent site surveys and personnel interviews, combined with related Rockwell-Collins experience, indicated the following specific equipment requirements:

- a. Communications center for fan-hole drill operator check in and vehicle dispatch.
- b. Alternate monitor station to assume communications center function should the communications center be vacant.
- c. Surface link to coordinate mine evacuation during disaster situations.
- d. Portable transceivers for fan-hole drill operators and roving mines with rechargeable batteries, capable of 8-hour operation.
- e. Vehicle mounted transceivers capable of being powered by the vehicle's 12 v dc power system.
- f. Battery backup for all stationary equipment.

The analysis required to determine cable type and size discussed in the previous paragraphs of this section essentially provided the general layout for the cable distribution network. This distribution network is shown in figure 9-4 and took into consideration communications area requirements based on site survey results. As is shown in figure 9-4, two repeaters were chosen to adequately cover all areas needing communications. The repeaters are located in two different areas, each being individual zones containing a repeater and associated runs of "leaky-feeder". With respect to the previous discussion relating interference problems between repeaters, the zones are electrically isolated by not physically connecting the two zones. Reviewing the previous discussion, the zone isolation was proposed as a solution to possible interference problems that could be created when a transceiver was within the range of either repeater. Additional benefits would be increased signal for critical areas, more latitude for new expansion, and simplified repeater interconnection.

Examination of possible linking methods for interconnecting the two repeater zones resulted in the selection of a unique rf link using two four-frequency repeater stations. Two frequencies would be dedicated to interzone communications, while the remaining two frequencies would provide the zone-to-zone link. An rf link had never been successfully implemented with a "leaky-feeder" system and was therefore a means of demonstrating maximum equipment capability and off-the-shelf technology to the mining industry. Use of an rf link preserves zone isolation while maintaining interconnection between zones. In addition, an rf link would allow usage of the "leaky-feeder" as the transmission path, reducing reliability problems that could be created by a wire-pair link.

Figure 9-5 shows the agreed-on link method using two four-frequency repeater stations. A four-frequency repeater station is made by crossconnecting two dual frequency repeaters with the proper audio and key line information*.

*Described in paragraph 10.0, equipment modifications.

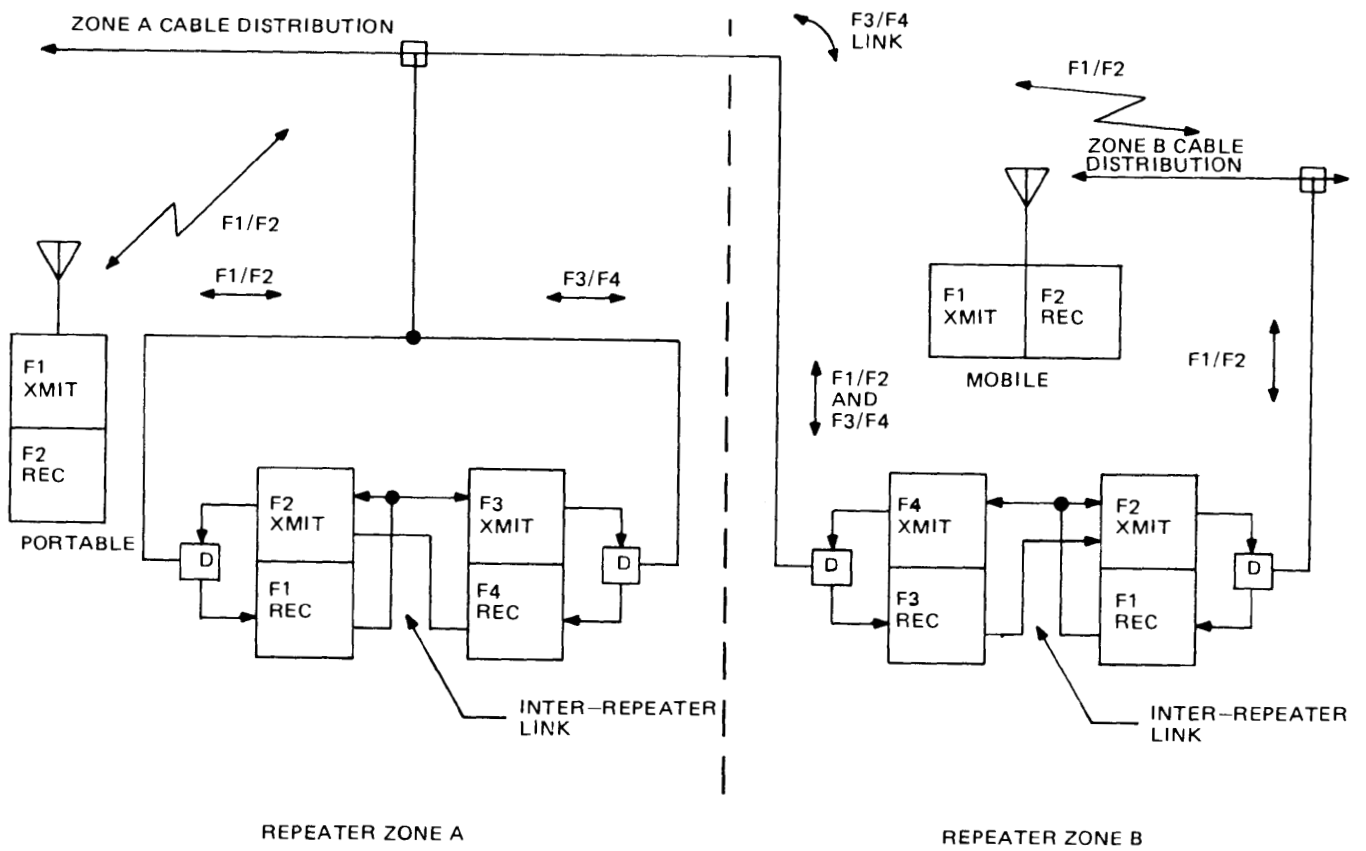

TP5-6730-011

Figure 9-5. Repeater Link Diagram.

Communications within a zone is established on F1 and F2 (since in a repeater-type system, mobile and portable transceivers use the same two frequencies except with reversed function, that is, F1 is transmit). As can be seen, no physical connection is required between F1/F2 repeaters. Information received within a zone on F1 is converted to F3 or F4 for transmission to the other zone. Received F3 or F4 information is then retransmitted on F2, thereby establishing a communications link between zones. A complete description of the four-frequency system operation is contained in paragraph 5.0 of this section. As can be seen, it is possible to expand a system of this type by adding more four-frequency repeater stations.

Combining the cable model shown in figure 9-4 with actual cable placement derived from a mine map and applying it to the link model shown in figure 9-5 yields the proposed "Leaky-Feeder" Cable Distribution Map of figure 9-6. If one were to transpose the map of figure 9-6 onto a mine map, the areas with "leaky-feeder" would follow main mine drifts (tunnels) and provide communications for the major portion of the sixth level. It should be noted that the reference to repeater zones D and E on figure 9-4 was changed to zones A and B, respectively, on figures 9-5 and 9-6.

The communications system requirements established during site surveys as well as the cable comparison and linking methods were reviewed with the USBM. The USBM concurred with the proposed system design and the design was presented to Grace Mine personnel as a solution to sixth-level vehicular and fan-hole drill operator communications problems. Grace Mine management approval was obtained and quantities of equipment established. Preliminary system specifications were written and forwarded to equipment manufacturers for possible recommendations. Recommended enhancements to the proposed system by the Communications Division of Motorola, Inc. and Andrews Corporation included the following:

- a. Reduce interference within a repeater station by assigning frequencies F3 and F4 in the vhf band.
- b. Provide surface link via hardwire remoting of alternate monitor station.
- c. Provide communications center function via remote audio/data information path to repeater station A.
- d. Combine paging function into selected portable transceivers.
- e. Establish paging from communications center.
- f. Use nonradiating cable between repeater station B and S2.
- g. Use flexible coaxial jumpers to connect the semirigid "leaky-feeder" to power splitters, repeater stations, and cable end antennas.
- h. Establish repeater B feed point at S2 (as shown on figure 9-6) and repeater A feed point at lowest point of mine (as shown on figure 9-6, No. 2 crusher room).

Consideration of manufacturers as to equipment availability, adaptability, and available service lead to the procurement of the following items by USBM:

- a. Repeater Station A
 1. Motorola "Compa-Station" Repeater, 450 MHz, C34MSY-3106AT, containing one each of the following modules:
 - (a) Tone Remote-Control Chassis, TCN1066A.
 - (b) Station Logic Module, TLN1173A
 - (c) Line Driver Module, TLN1172A
 - (d) F1/PL Module, TLN 1244A

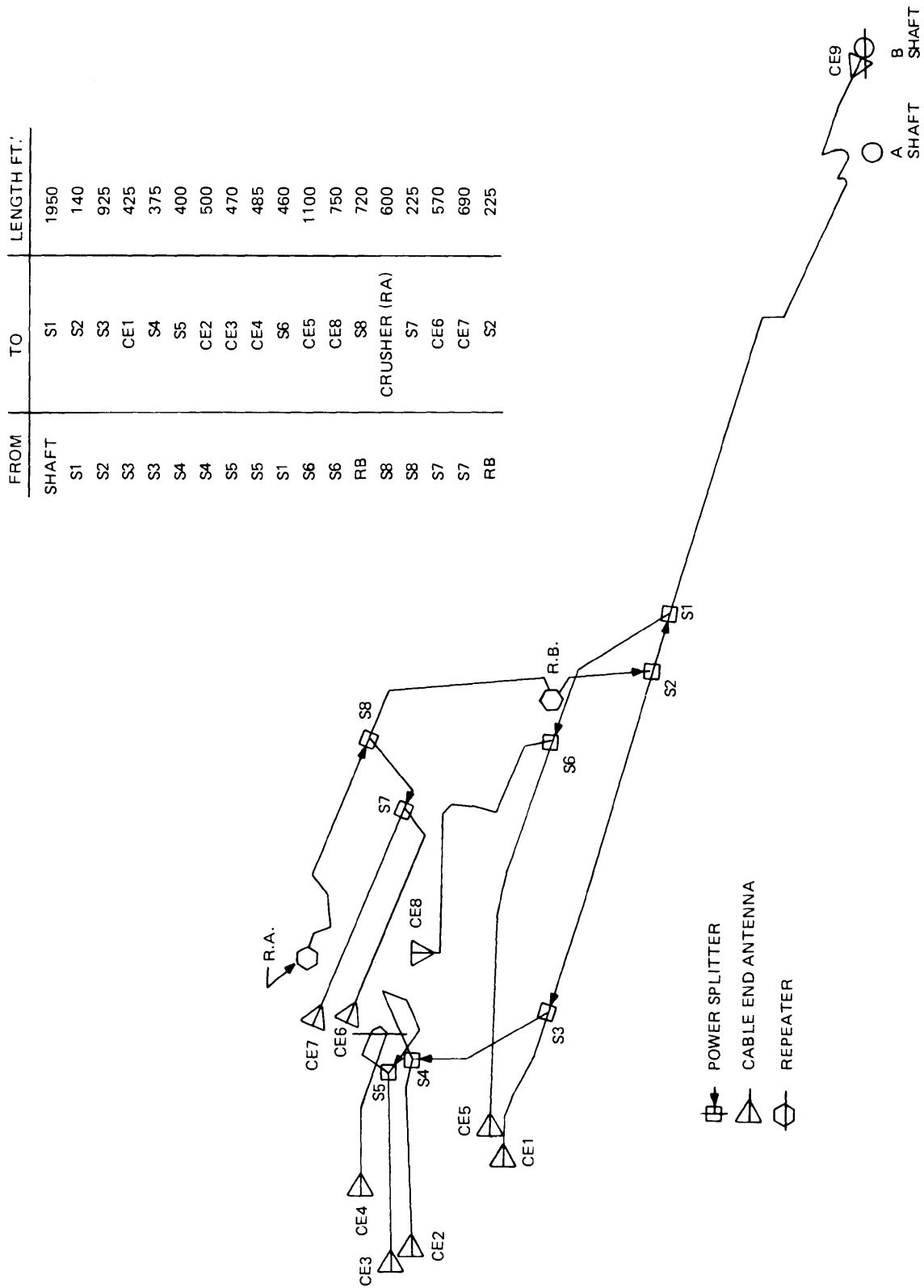



-  POWER SPLITTER
-  CABLE END ANTENNA
-  REPEATER

Figure 9-6. "Leaky-Feeder" Cable Distribution Map.

TP5-6731-011

- (e) Squelch Gate Module, TLN1180A
- (f) Time Out Timer Module, TLN1179A
- (g) Guard Tone Decoder Module, TLN1245A
- (h) Paging Control Module, TLN1253A
- (i) Repeater Duplexer, T1507F

2. Motorola "Micor" Repeater, 150 MHz, C53RCB-3106BT with C77 outdoor cabinet, containing one each of the following modules:

- (a) Remote-Control Chassis, TCN1107A
- (b) Squelch Gate Module, TLN4662A
- (c) Station Control Module, TLN4635A
- (d) Time Out Timer Module, TLN4636A
- (e) Line Driver Module, TLN4668A
- (f) Guard Tone Decoder Module, TLN1245B
- (g) F1/PL Control Module, TLN4638A
- (h) "PL" On/off, C53AB
- (i) 4-Wire Kit, C144
- (j) DC Metering Kit, C149
- (k) Relay Kit, TLN4151

b. Communications Center

1. Motorola Tone Remote Control Console, T1605AM, containing one each of the following modules:

- (a) Tone Encoder Board, TLN4870A
- (b) Intercom Switch Kit, TLN4973A
- (c) Alert Tone Kit, TLN4991A
- (d) "Private-Line" Control Kit, TLN4992A
- (e) VU Meter Kit, TLN4988A
- (f) Alternate Line Switch Kit, TLN4977A
- (g) Desk Microphone, TMN1005A
- (h) 4-Wire Kit, TLN4989

2. Motorola Page Encoder, N1017B

c. Repeater Station B

1. Motorola "Compa-Station" Repeater, 450 MHz, C34MSY-3106AT, containing one each of the following modules:

- (a) Tone Remote-Control Chassis, TCN1066A
- (b) Station Logic Module, TLN1173A
- (c) Line Driver Module, TLN1172A
- (d) F1/PL Module, TLN1244A
- (e) Squelch Gate Module, TLN1180A
- (f) Time Out Timer Module, TLN1179A
- (g) Guard Tone Decoder Module, TLN1245A
- (h) Paging Control Module, TLN1253A
- (i) Repeater Duplexer, T1507F

2. Motorola "Micro" Repeater, 150 MHz, C53RCB-3106BT with C77 outdoor cabinet, containing one each of the following modules:
 - (a) Remote-Control Chassis, TCN1107A
 - (b) Squelch Gate Module, TLN4662A
 - (c) Station Control Module, TLN4635A
 - (d) Time Out Timer Module, TLN4636A
 - (e) Line Driver Module, TLN4668A
 - (f) Guard Tone Decoder Module, TLN1245B
 - (g) F1/PL Control Module, TLN4638A
 - (h) "PL" On/off, C53AB
 - (i) 4-Wire Kit, C144
 - (j) DC Metering Kit, C149
 - (k) Relay Kit, TLN4151

- d. Alternate Monitor Station (Qty 2)
 1. Motorola Console Base Stations, L34BCB-3104BM, each containing the following modules:
 - (a) Control Panel and Chassis, TLN4403A
 - (b) VU Meter Kit, TLN1368A
 - (c) Alert Tone Oscillator, TLN1369A
 - (d) Time Out Timer, TLN1097A
 - (e) Emergency Power Reverting kit, TLN13744
 - (f) Remote-Control Chassis, TLN1127A
 - (g) Relay Kit, TLN8575A
 - (h) Monitor/Intercom Kit, TLN
 - (i) Desk Microphone, TMN1005A

- e. Surface Link
 1. Motorola Remote Desk Phone, T1379A

- f. Vehicle Transceivers
 1. Motorola Industrial Dispatcher Radio, D34DCN-3100AT, (qty 8)

- g. Portable Transceivers
 1. Motorola HT-220 Handie Talkie with page decoding circuitry, H34FFN 2137-SP, (qty 4)
 2. Motorola HT-220 Handie Talkie without page circuitry, H34FFN 3134N, (qty 6)
 3. Motorola HT-220 Battery Charger (12 units), NL-6898B
 4. Motorola Battery Charger (single unit), NLN-6897A
 5. Battery, NLN6900 (qty 14)

- h. Cable Plant
 1. 11,000 feet Andrews RX5-1R Radiax cable cut to the following lengths (feet):
2000, 950 (3), 875, 315, 280, 320, 340, 525, 605, 170, 420, 545, 1755
 2. 1000 feet Times Wire and Cable 875 Cert cable

3. 225 feet Andrews FHJ5-50A Heliac cable with one Andrews 45A N connector attached at each end
4. Connector, Andrews 45AW (qty 12)
5. Connector, Andrews 45AN (qty 25)
6. Connector, Andrews 45AU (qty 11)
7. Connector, Andrews 45A P (qty 1)
8. Splice Kit, Andrews 45AZ (qty 14)
9. Power Splitter, Andrews 42152 (qty 16)
10. Cable Hanger, Andrews 40954 (qty 55)
11. Antenna, DB708 (qty 11)

These components were forwarded to Rockwell-Collins, under provisions of USBM Contract S0133035, for formulation into a system that would satisfy the communications requirements of the Grace Mine.

The steps taken by Rockwell-Collins to successfully modify and test the equipments implemented in the Grace Mine are described in paragraph 10.0, system modifications.

10.0 RF "LEAKY-FEEDER" COMMUNICATION EQUIPMENT MODIFICATIONS

10.1 Introduction

The communications equipment implemented in the Grace Mine required that modifications be performed to the equipment control functions and that special "leaky-feeder" connections be made. System engineers at the Communications Division of Motorola, Inc. performed a preliminary design of a basic rf "leaky-feeder" communication system that could be used at the Grace Mine. From this basic design, a general selection of equipment was procured. Equipment as identified in paragraph 9.0 was shipped to Rockwell-Collins facilities at Cedar Rapids, Iowa, for complete functional design, modification, and testing. The end result was to be a system that would satisfy the communications requirements of the Grace Mine vehicular and roving miner traffic and the fan-hole drill operators. The following paragraphs describe the interrelationships between equipment and the various modifications required.

10.2 System Operation

The communications equipment at the Grace Mine consists of two separate repeater stations placed such that two separate areas of uhf rf propagation are realized. Mine personnel communicate with each other using portable handheld transceivers, vehicular mounted mobile radios, or alternate monitor stations. The Grace system also utilizes a communications center where central control is established.

The communications center, located at the No. 2 Crusher, consists of a Motorola Tone Remote Control Console TIBOSAM, a Selective Paging Encoder N1017B, and the appropriate interface to repeater station A. From this location communication traffic is monitored and controlled. In addition, paging, alert tone, voice communications, and maintenance intercom functions are installed.

Utilizing the paging function, a remote radio with paging mode selected does not respond to normal voice communications, but will respond with an audible signal when a page is received. A page transmission consists of two encoded tones transmitted sequentially. When the signal is received by the remote radio it is decoded and an audible page call is heard. To prevent interruption of remote radios not having the page capability, private line coded squelch is used. Private line coded squelch is a subaudible signal which is transmitted with normal voice and when received by a remote radio, an audio squelch circuit decodes the subaudible signal. During a page transmission, the subaudible tone is removed allowing remote radios containing the page mode to respond.

An alert tone (1 kHz) signal, transmitted at a high audio level is used for alerting purposes. When activated, operators at remote and alternate monitors receive the alert tone in the same manner as in normal voice traffic.

The communication center is remotely located from repeater station A, and is connected using single wire pair. All operating functions are accomplished by using encoded tones. Repeater station A contains two separate but interconnected repeaters, one vhf-fm and one uhf-fm. The uhf-fm repeater is a Motorola "Compa-Station" (450 to 470 MHz) C34MSY-3106T. The vhf-fm repeater is a Motorola "Micor" (132 to 174 MHz) C53RCB-3106BT. The two units are interconnected by discrete wires which allow operation as a single repeater with a link function. The vhf and uhf repeaters that make up the repeater station contain circuits which allow remote tone operation of all system functions. Repeater station B is identical to station A except it does not have the remote control console.

Figure 10-1 shows signal flow (audio and control) between the various assemblies of the system. The page encoder is hardwired to the tone remote-control console. Command signals are generated by the tone remote-control console. The command signals are then coupled by a wire pair to control circuits in transmitter T₂ and T₃, where a keying signal is developed for keying the transmitters.

Uhf transmitter T₂ transmits signals into zone A and the vhf transmitter T₃ transmits signals to vhf receiver R₃ at station B. Receiver R₃ couples the vhf signal to uhf transmitter T₂ and retransmits the signal at a uhf frequency to zone B. Hardwire control of the system occurs only through repeater station A, as repeater station B has no control capability and responds only to commands originating in zone A or from uhf receiver R₁ in zone B. When the system is accessed through either repeater station, the audio removed at R₁ and R₄ is automatically routed to the communications center.

Incoming signals to receiver R₁ (zone A) cause transmitters T₂ and T₃ to key, while signals received by receiver R₄ keys transmitter T₂ only. This occurs when the system is accessed by portable transceivers, vehicular mounted radios or alternate monitor stations. Each of these units is equipped with key-line circuitry. Incoming signals received by receiver R₁ (zone B) keys transmitters T₂ and T₄. Signals received by receiver R₃ keys transmitter T₂ only.

Since only a single wire connects the repeater stations, the output/input to repeater station A are brought out to a type N "T" connector to minimize voltage standing-wave ratio (vswr). Repeater station B does not require a "T" connector due to the physical location of the repeater station.

10.3 Repeater Assemblies

The Grace Mine system has two repeater stations. Each station has two repeater assemblies; each assembly consists of a receiver, exciter, power amplifier control, duplexer, and power supply. This permits the station to receive data and "repeat" the data at a different frequency and at a higher power level. One repeater operates at uhf frequencies and the second operates at vhf frequencies. Through various control circuits, data is fed from the receivers to the transmitters for transmission through the communication system. The control circuits required extensive modification to integrate the two repeaters into a functional control station.

The control circuits were wired to provide automatic keying of the transmitters by the received signals as described in paragraph 10.2. The two repeaters are identical with the exception of the control circuit wiring.

The vhf repeaters serve as the link between repeater stations A and B. The uhf repeaters are the communication medium with portable and mobile transceivers and alternate monitor stations through the "leaky-feeder".

The use of vhf to interconnect two uhf zones at the Grace Mine is a unique concept. The system was used to demonstrate to the mining industry maximum equipment capability while eliminating the need of wire pair interconnect.

The uhf "Sensitrons" are dual-conversion superhetrodyne fm receivers. The receivers operate in the range of 450 to 470 MHz. The "Sensitrons" are of solid-state construction and were manufactured by Motorola.

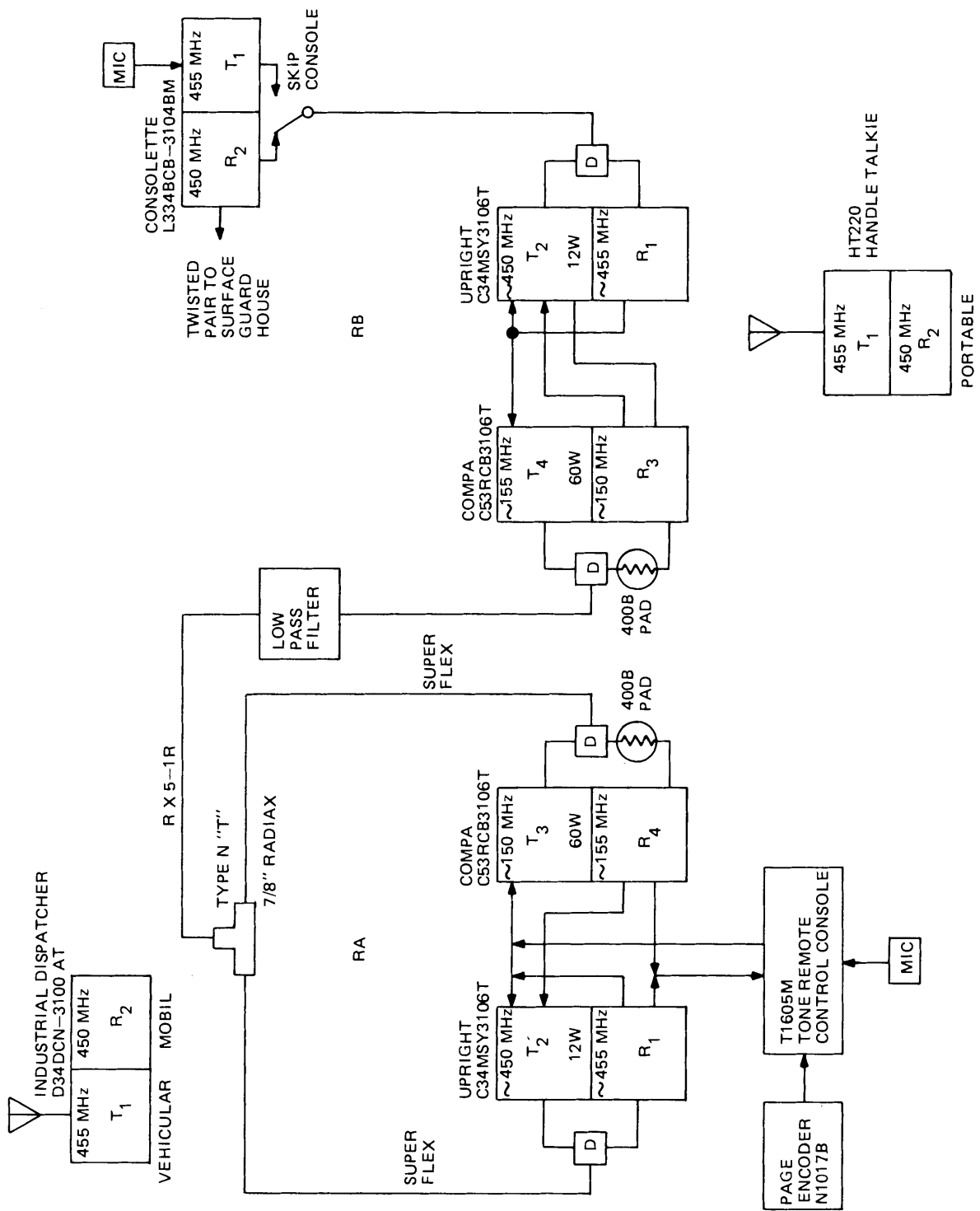

Figure 10-1. "Leaky-Feeder" System Block Diagram.

The receiver contains circuits for decoding the subaudible private line (PL) tone coded squelch. The resulting signal is used to disable the receiver squelch. In addition, a shield kit is used with the receiver for decoupling ac voltages at dc test points.

The exciter/power amplifier module provides a phase-modulated rf signal (450 to 470 MHz) at an output level of 12 watts (nominal). The output of the power amplifier is applied through a duplexer to the "leaky-feeder". The duplexer permits the repeater to transmit and receive simultaneously by isolating the output of the power amplifier from the receiver input.

Dc operating voltages for equipment operation and charging backup batteries are supplied by the power supply. Input power is 115 v ac mine power. The vhf receiver operates in the 132 to 174 MHz range, developing a low noise level signal from the incoming fm signal.

The vhf exciter/power amplifier generates the carrier frequency, modulates it, and amplifies it to an rf output level of 60 watts.

Both vhf and uhf control circuits are housed in remote-control chassis assemblies. The chassis assemblies are wired to accept several different control modules providing different functions for the repeaters. Selection of control modules is dependent upon the requirements of the individual repeater.

Because repeater station A (RPTA) is interconnected to the communications center, more control modules are required in RPTA than in repeater station B (RPTB). Control module complement of the repeater station is listed in table 10-1.

Table 10-1. Control Module Complement.

Uhf		Vhf	
Function	Type	Function	Type
Station Logic	TLN1173A	Station Control	TLN4635A
Line Driver	TLN1172A	Line Driver	TLN4668A
Squelch Gate	TLN1180A	Squelch Gate	TLN4662A
Line Out	TLN1179A	Time Out	TLN4636A
Guard Tone Decoder	*TLN1254A	Guard Tone Decoder	TLN1245B
F1/PL	*TLN1244A	F1/PL	TLN4638A
Paging Control	TLN1253A		

*Denotes deleted modules from RPTB

The separate uhf and vhf repeaters within a repeater station are interfaced with each other through key lines and a common audio bus. Figure 10-2 (sheets 1 and 2) is a block diagram showing repeater A and B stations control modules interconnections, audio signal flow, and key-line control.

Paging control, guard tone decoder, and F1/PL modules interface uhf repeater tone control and remote control console. The guard tone decoder responds to a guard tone command generated in the communications center, and converts it to a push-to-talk command.

Remaining function tones received from the communication center are amplified and distributed to the F1/PL and paging control modules by the guard tone decoder. When the monitor command is received from the communication center, a tone specific to the monitor command is generated and coupled to the F1/PL module where it is decoded as a private line coded squelch disable command. The uhf receiver then reverts to carrier squelch operation. Operating frequency for a specific transmitter is selected when the F1/PL module receives a transmit command tone from the communication center. The four exciter/power amplifiers in the Grace Mine system are tuned for single-frequency operation. When a page command is initiated by the communication center, the tone is decoded and the exciter/power amplifier transmit private line tone is disabled, allowing only portable transceivers capable of paging service to respond. The uhf squelch control circuits are contained in the logic module which has keying control over the exciter/power amplifier. Keying signals are also received from the vhf squelch gate module. Incoming audio is amplified by the station logic card before being coupled to the exciter/power amplifier. The line driver receives and transmits vhf and uhf audio signals between the communication center and the repeater A station. The line drivers increase the signal levels for transmission. (Refer to figure 10-2.)

Figure 10-3 is an interconnect wiring diagram of the RPTA uhf and vhf repeaters. Resistors R1 through R6 is a 3-part bridge offering a common impedance to the line drivers. Incoming audio from the uhf receiver is applied to the station logic module where it is routed to a squelch threshold circuit in the uhf gate squelch module. When fm quieting is sensed by the squelch threshold circuit, a key signal is generated and coupled to the uhf and vhf logic modules, keying both transmitters. A timer module prevents leaving the transmitter keyed for excessive periods of time. Transmit time may be selected for periods of up to 8 minutes, by a strapping arrangement on the timer module.

The vhf link from RPTA exercises control in the same manner as the uhf section of RPTA except for repeater action and paging (refer to figure 10-2). Incoming audio from the vhf receiver is coupled into the vhf squelch gate logic module, developing the keying signal which is coupled to the uhf station logic module rather than the vhf station logic module. This signal flow is identical in RPTB. The link function does not operate with private line encoded squelch, since remote radios do not use vhf frequencies. Therefore, no paging module is required in the vhf control section of RPTA.

Operation of repeaters A and B are very similar, major differences being the manner in which connections are made to the "leaky-feeder", absence of the communications center, guard tone decoder, and F1/PL module which are not required (refer to figure 10-2). Figure 10-4 shows the interconnect wiring of RPTB.

A built-in metering function permits monitoring of twenty major voltage test points in the receiver and exciter/power amplifier circuits.

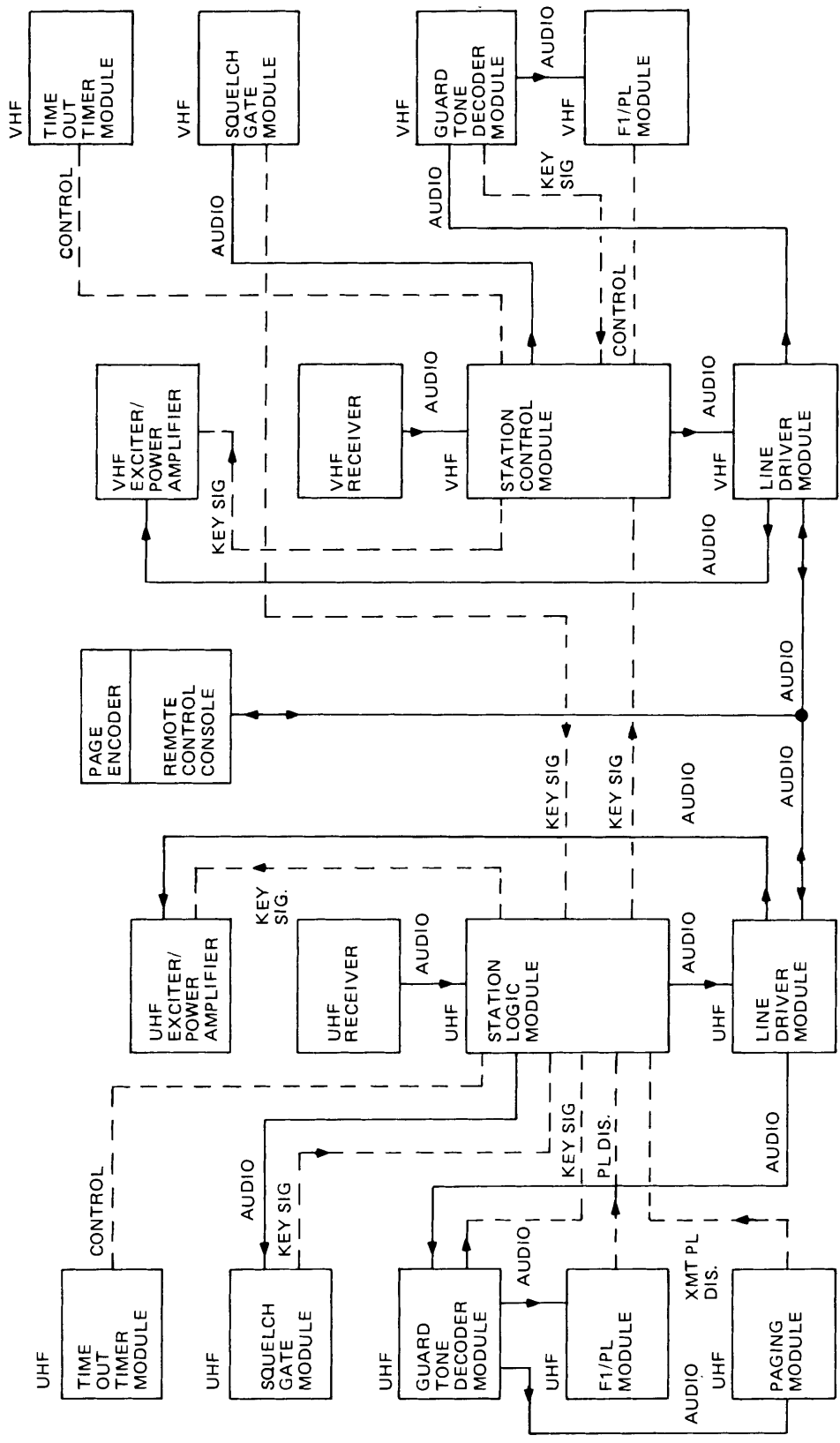

REPEATER A STATION

Figure 10-2. Repeater A Station (Sheet 1 of 2).

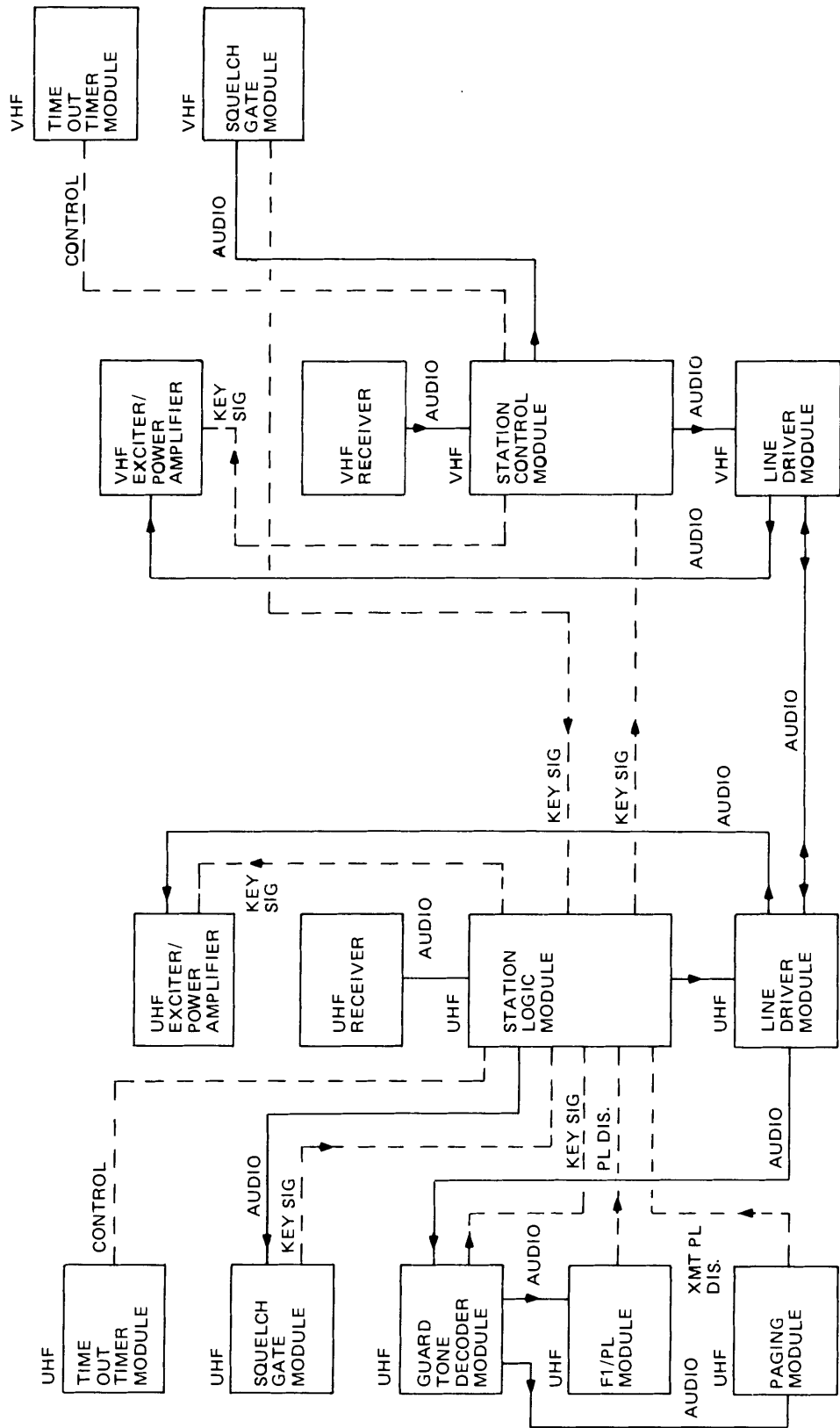

REPEATER B STATION

Figure 10-2. Repeater B Station (Sheet 2).

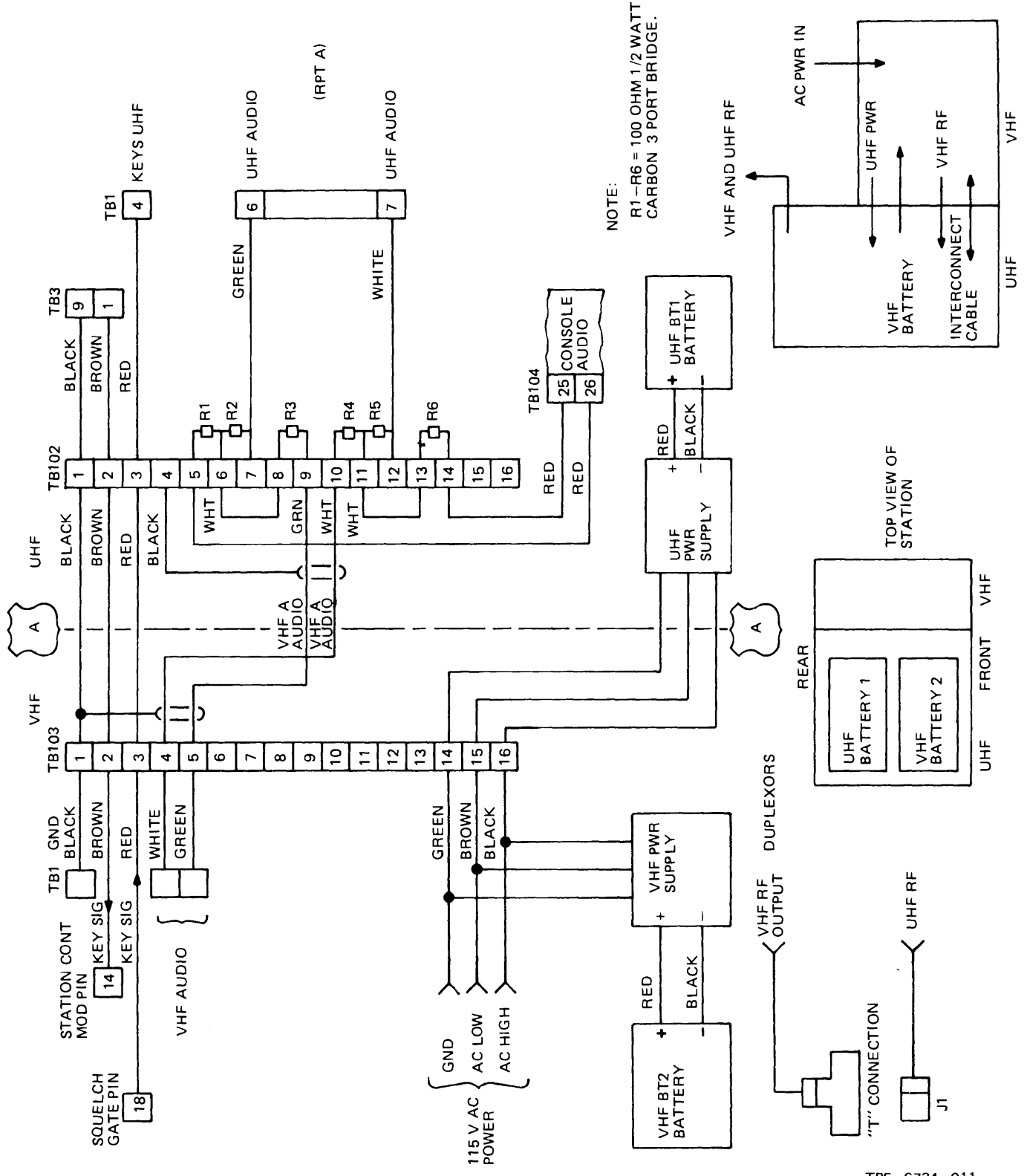

Figure 10-3. RPTA Interconnect Wiring.

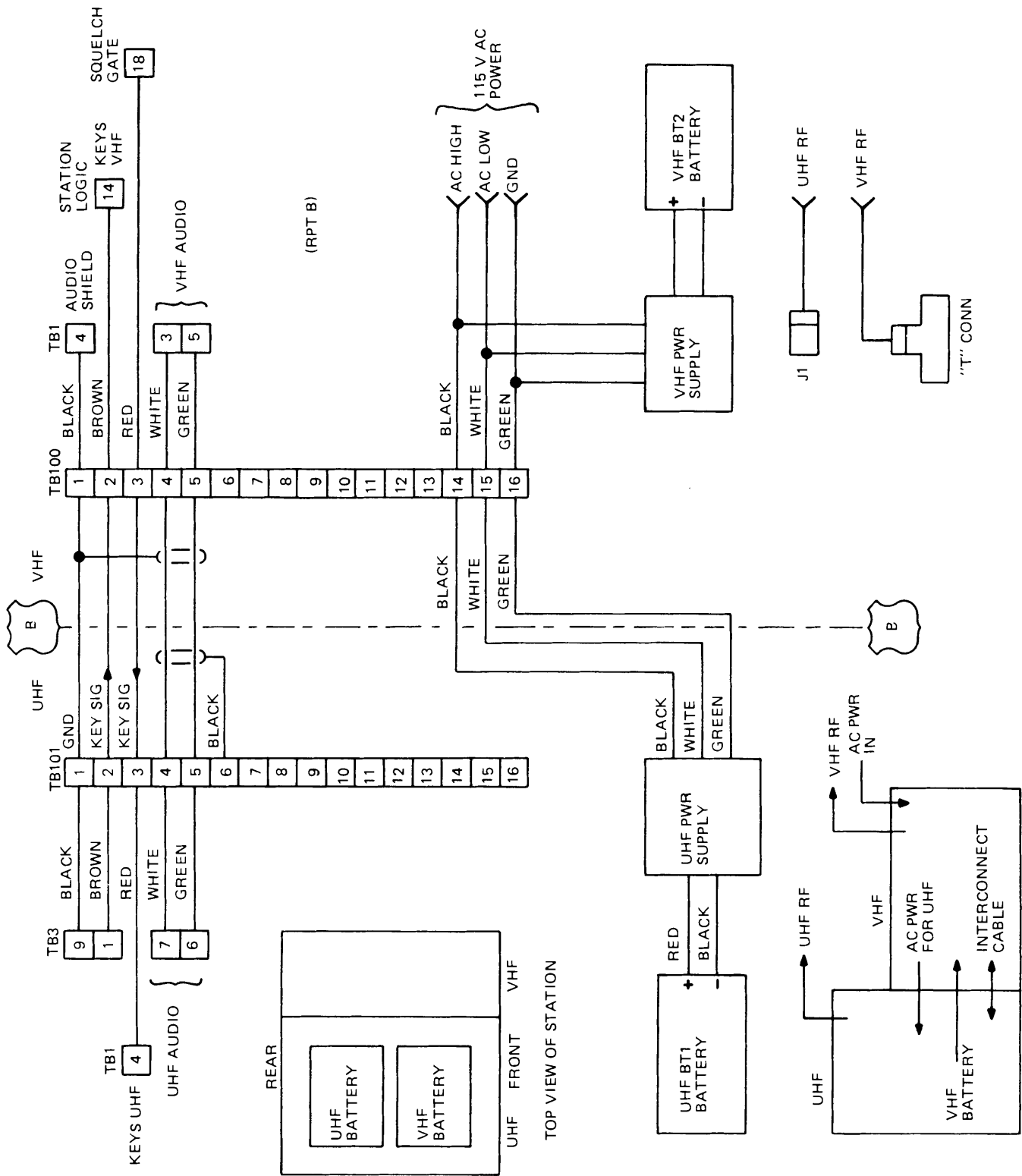

Figure 10-4. RPTB Interconnect Wiring.

TP5-6735-011

115 v ac is required by the power supply module to produce the dc voltages used in the system. Both uhf and vhf repeaters contain independent power supplies (refer to figure 10-5 for power supply chassis location) providing current limiting and overvoltage protection. During a power outage, the system automatically reverts to backup battery power. A battery protection and alarm circuit superimposes a periodic "beep" on all transmitted signals to inform operators that the system is operating on backup power. Standard automotive wet lead acid batteries are used. The batteries are maintained at full charge by trickle charging from the power supply module. Refer to figure 10-5 for battery locations.

10.4 Communications Center

The communications center contains a Motorola T1605AM tone remote-control console providing required functions to operate the communications center. Control functions include the following:

- a. Tone control between the console and repeater station A.
- b. Intercom function between the console and repeater station A.
- c. A system alert tone.
- d. Private line coded squelch disable (used as a monitor function).
- e. Vu meter indication of audio levels.
- f. Paging to selectable remote transceivers.

When required, an intercom switch permits two-way communication with repeater station A without keying the exciter/power amplifier. The vu meter gives the operator a visual indication of transmit and receive audio signal levels. To obtain the functions described above, modular plug-in (called kits) were installed in the console.

A tone encoder kit permits control of repeaters using tones encoded with audio. The tone encoder generates high- and low-level guard tones. The high level initiates tone action and the low level holds the exciter/power amplifier keyed. In addition to guard tones, function tones are also generated for transmit, private line disable, and paging.

A private line control kit and selective paging encoder permits selection of individual remote transceivers. When a page is initiated, the transmit private line tone is disabled and the selected transceiver page is encoded.

10.5 Communications Center Modifications

To make the remote tone console compatible with the Grace Mine two-wire system, an alternate line switch kit (TLN4977A) and a 4-wire audio kit (TLN4489) were removed from the console.

10.6 Repeater Station A Modification

To make repeater station A compatible with the Grace Mine system, a remote control relay kit (TLN4151) and 4-wire kit (C144) were removed.

10.7 Repeater Station B Modification

To make repeater station B compatible with the Grace Mine system, the tone decoder module (TLN1245B), remote control relay kit (TLN4151), 4-wire kit (C144), and F1/PL module were removed.

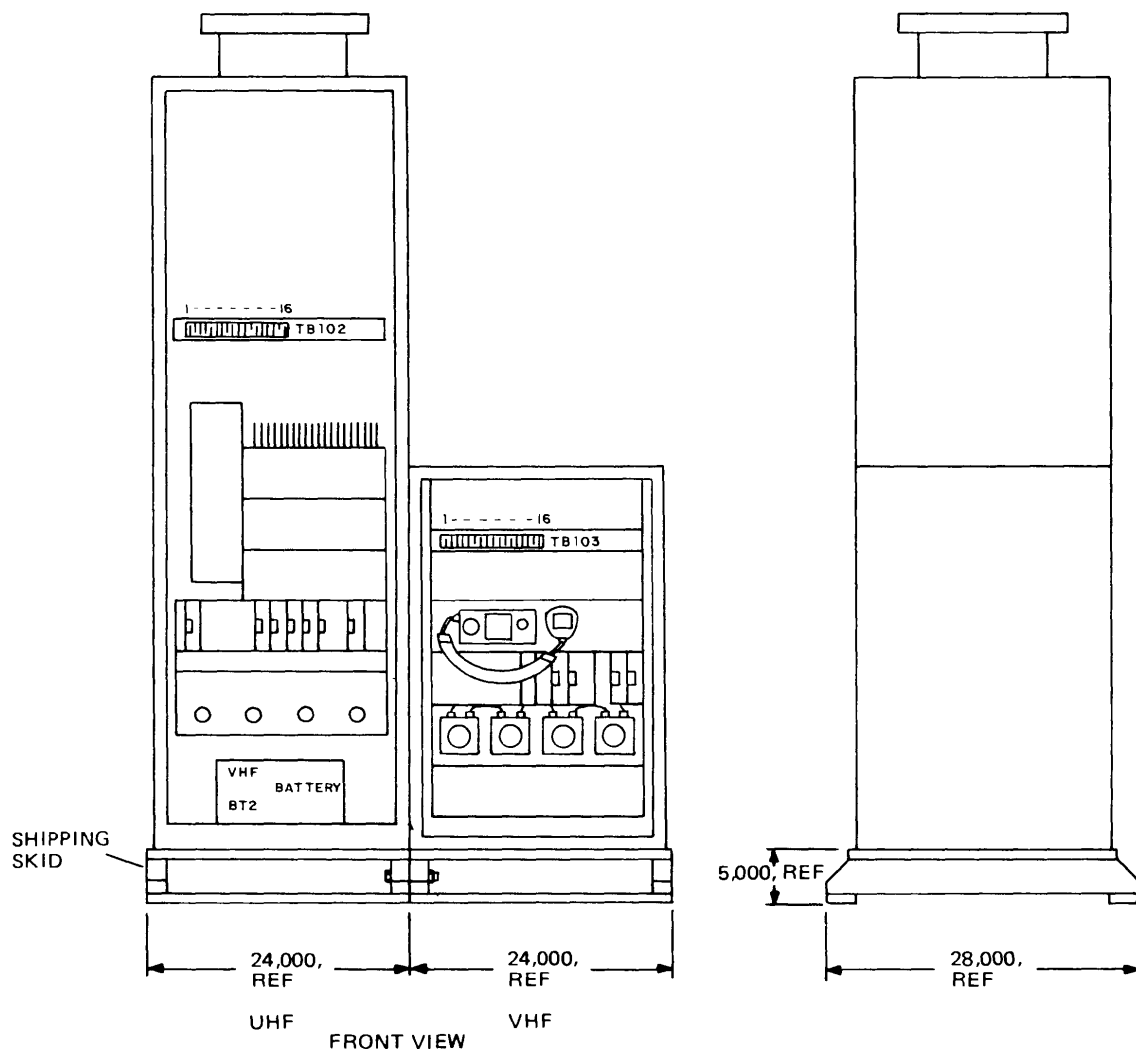

TP5-6736-021

Figure 10-5. Component Location Diagram (Sheet 1 of 2).

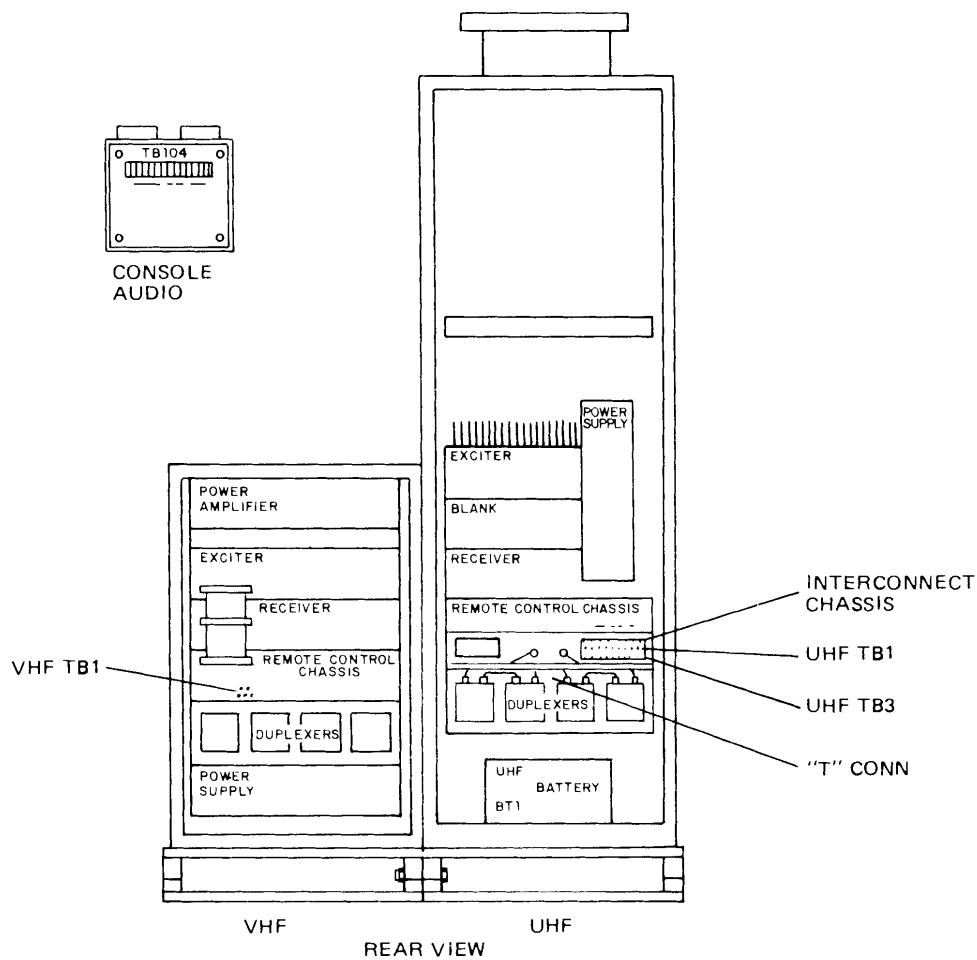

TP5-6736-021

Figure 10-5. Component Location Diagram (Sheet 2).

10.8 Mechanical Modifications

To facilitate transport of the vhf and uhf subassemblies, final assembly was not accomplished until arrival at the final installation point. To prevent contact with the mine floor, the subassemblies were installed on custom pallets (refer to figure 10-5). The hardwiring required between the two units was accomplished using easily accessible terminal blocks located at the rear of the cabinets.

10.9 Alternate Monitor Station Modifications

The alternate monitor station is a console base station manufactured by Motorola containing subassemblies listed in table 10-2.

The circuit shown in figure 10-6 was added to provide proper audio switching between NORMAL and INTERCOM operations, and between alternate monitor station and the desk set in the guardhouse.

Table 10-2. Alternate Monitor Station Subassemblies.

DESCRIPTION	TYPE	DESCRIPTION	TYPE
Control panel/chassis	TLN4403A	vu meter kit	TLN1368A
Time out timer	TLN1097A	Alert tone oscillator	TLN1369A
Emergency power reverting kit	TLN1374A	Remote control chassis Monitor intercom kit	TLN1127A TLN
Relay kit	TLN8575A	Desk microphone	TMN1005A

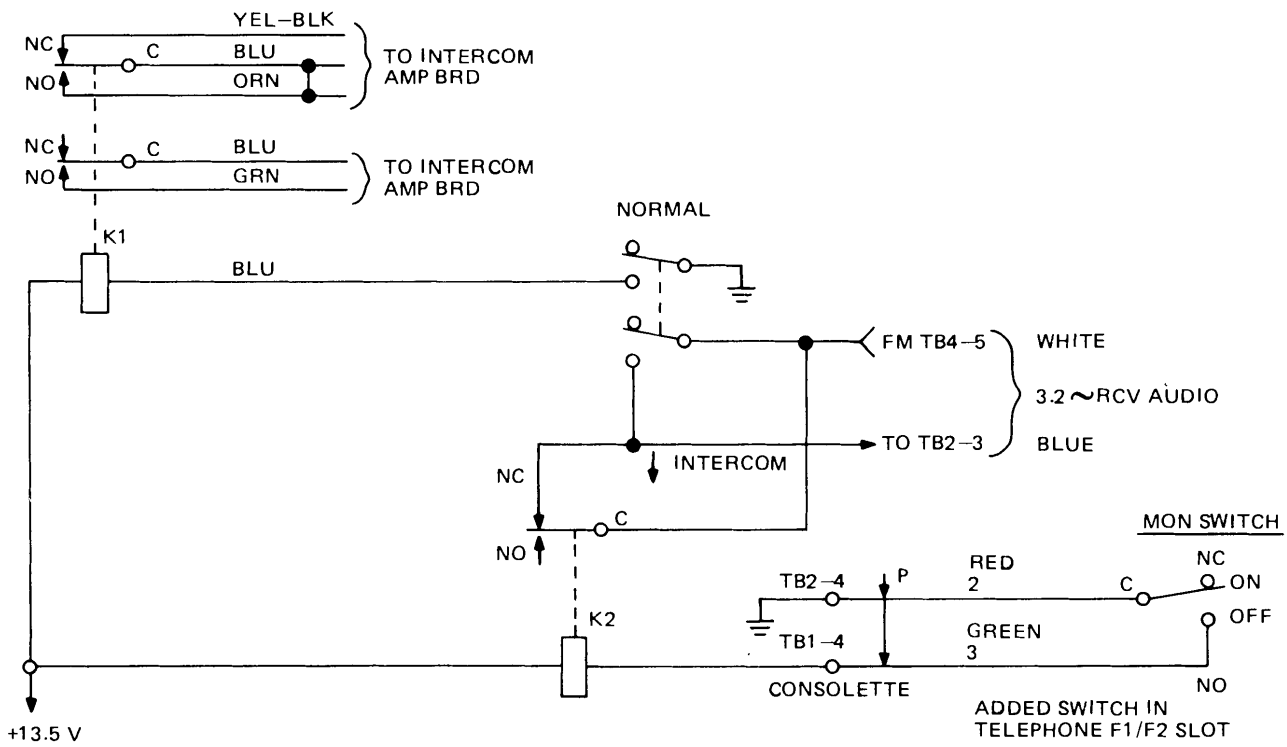

TP5-6737-011

Figure 10-6. Audio Switching Circuit.

SECTION III

A Communications and Monitoring System for a Deep Underground Silver Mine

Sunshine Mine

1.0 INTRODUCTION

The Coal Mine Health and Safety Act of 1969 authorized the United States Bureau of Mines to undertake research that would lead to increased safety in mines. This research included the development of new or improved means and methods of communication during normal day-to-day and emergency situations.

This section of the report (Section III) describes the efforts to provide improved communications at the Sunshine Deep Metal Mine located in the northwestern United States.

2.0 SUNSHINE MINE DESCRIPTION

The Sunshine Mine is centrally located in the great silver belt of the Cour d'Alene mining district in Big Creek Canyon about 8 miles east of Kellogg, Shoshone County, Idaho. The mine first opened in 1884, and is presently operated by the Sunshine Mining Company.

Employment at Sunshine is 514 persons, 400 of whom work underground. The main access to the mine is through a 200-foot long adit to the Jewell shaft at the western edge of the mine. A miner proceeds down that shaft to the 3100 and 3700 levels and then eastward through 500-foot long drifts to the No. 10 shaft, which is collared at the 3100 level. He must then go down that shaft to the active working levels (figure 2-1).

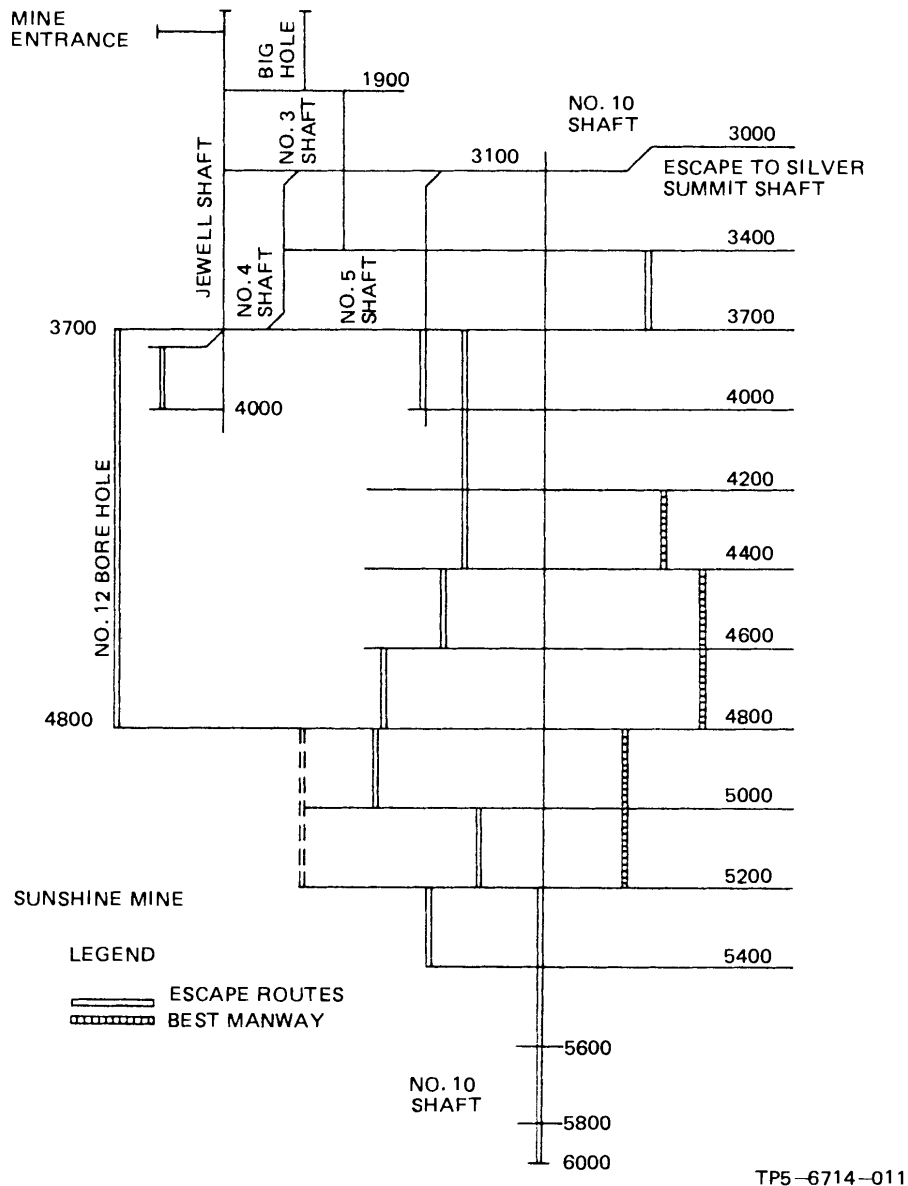

TP5-6714-011

Figure 2-1. Sunshine Mine Map.

The No. 10 shaft is bottomed just below the 6000 level. Ore is being produced on the 4000, 4200, 4400, 4600, 4800, 5000, and 5400 levels. Level development is in progress on the 5600 level; shaft station development is in progress on the 5800 level.

Both the Jewell and No. 10 shafts utilize electrically powered double-drum and single-drum chippy hoists. The double drum hoists in both shafts are used primarily for hauling ore and waste materials. The chippy hoist in the Jewell shaft is used for moving men and materials to all levels down to the 4000 level and for hoisting ore from the 4000 level to 3100 level. The No. 10 chippy hoist is located at the 3700 level and is equipped with a four-deck man cage with a total capacity of 48 men. It is used in servicing all levels below 3700.

Airflow for the Sunshine Mine depends upon pressure developed by fans located underground (series ventilation). All intake air for ventilation of the mine is coursed down the Jewell shaft to the 3100 and 3700 levels. The air is split between these two levels and travels laterally to the No. 10 shaft, where it is then forced down to the lower levels. The return air flows through ventilation raises and exhaust airways to the surface.

The principle ore mined at Sunshine is tetrahedrite. Ore deposits occur as long, generally narrow, mesothermal replacement veins containing sulfides of silver, copper, lead, and antimony in a carbonate quartz gangue. In the Sunshine Mine, the veins have a strong general N 80° W direction (roughly parallel to the Big Creek Anticline fault). The vein dips vary from 45° to 90° and are generally to the south. Strike lengths on the major ore shoots range up to a known maximum of 2200 feet and are normally exceeded twofold or threefold vertically along the dip of the structure. The true vein width varies considerably but generally averages between 2 and 5 feet.

The steeply dipping fissure veins are mined by the horizontal cut and sandfill method, by either breasting down or back stoping (figure 2-2). Stopes are developed a maximum of 100 feet along the strike of the vein. Level intervals are 200 feet. A raise climber is used to drive the 6-by-6-foot raises between levels.

Ground is controlled in drifts by steel mats and 3/4-inch diameter rockbolts, 4 and 6 feet in length. The mats and bolts are used above, or in conjunction with, drift timber. Stulls and 3-piece timber sets with squeeze caps are used in combination with rockbolts and headboards to support ground-in stopes. Sandfill, with cement capping, is used to stabilize the mined-out sections of the stopes.

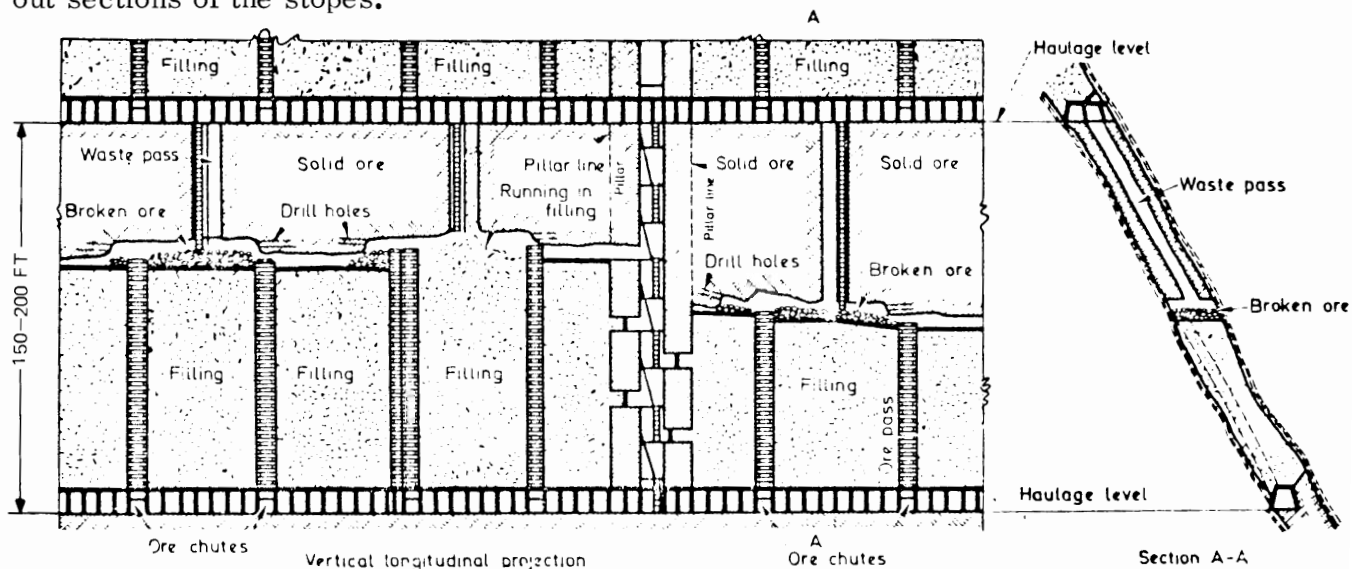

Figure 2-2. Example of Horizontal Cut-and-Fill Stopping.

All underground transportation is accomplished using either the hoists or battery-powered locomotives on narrow gauge tracks. The mined ore is transported to a muck pocket on the associated haulage level. This ore, or muck as it is called, is then dumped onto the No. 10 hoist skips and transported to the 3100 level of the No. 10 shaft. The muck is then transported by locomotive to the Jewell shaft and hoisted 3100 feet to the headframe storage bins.

The mined ore (maximum size 12 inches) is then fed to the crushing plant where it is crushed to minus 1/2 inch. Continued grinding of ore occurs in the ball mill where it is ground to 60 percent minus 200 mesh. The valuable minerals are then separated from the waste rock using selective flotation methods. Low grade silver concentrates are ground to a finer 95 percent minus 325 mesh. Silver, lead, and copper concentrates are then sold to smelters. Antimony is recovered in a metallic, marketable form, using electrolysis.

Surface facilities include an office area, warehouse, electric shop, machine shop, hoist and compressor house, garage, carpenter shop, mine and mill change house for employees, dispensary, and tailing ponds. Engineering personnel are located at the mine to provide facility planning and improved control of the mining operation.

3.0 STATEMENT OF THE PROBLEM

A discussion of the communications and monitoring problems at the Sunshine Mine can be accomplished by describing the various subsystems as they existed at the beginning of the Engineering and Administrative Services Contract effort in 1975. A description of these subsystems is presented in the following paragraphs.

3.1 Hoist Communications

Communication with the hoistman on both the Jewell and No. 10 shaft is accomplished with a bell-code system. A bell-bottle switch is mounted at each shaft station, and a pull cord hangs approximately 1 foot outside the cage. A smaller pull cord extends from another bell switch down the shaft to the next station. This second cord is held in position next to the shaft timbers by staples. During shaft inspections, this cord is used for emergency stops and signaling between shaft stations.

Although reliable, the bell system has several severe shortcomings. First, all signaling requires the operator to reach out of the cage and grab a cord, which may be moving relative to the cage. This action can easily put the operator's arm or hand in a dangerous situation. Second, the emergency stop cords do not function well at any hoisting speed other than very slow. A long pull on the cord is required to take up the slack and operate the switch. If the cage is traveling downward at a normal speed, the staple that holds the cord may severely injure the operator's fingers. If the cage is traveling upward, the pull requires even greater effort since the operator has to pull down on a stationary cord while he is moving in the opposite direction. Signaling for shaft inspection or repair, where movement of the cage must be controlled precisely, is difficult using the bell-code signals on the emergency stop line. On-cage communication directly with the hoist operator would be safer and more efficient.

3.2 Telephone Communications

The Sunshine Mining Company operates an automatic switchboard for telephones in surface offices and shops; however, the system does not extend underground. The underground telephones are on a separate party-line system. Signaling on the underground system is accomplished by using 115 v ac buzzers. This requires an additional pair of ac wires and a signaling switch which are mounted with each telephone. These underground telephones are located at gathering points such as shaft stations, hoist rooms, and maintenance shops.

The surface-to-underground communication link consists of several party-line phones installed in strategic surface locations, such as the electric shop, shifters shack, machine shop, and the hoist room. An emergency telephone line from the 3700 No. 10 Blue Room area to the surface safety office was installed. Another telephone system manufactured by Executone* was purchased but was not installed because of the large amount of wiring (20 pairs) required. Installing such multiconductor wire down the shafts of the 1600-foot deep mine was a major deterrent to this installation.

The major drawback to the party-line system is that only one conversation can be held at any given time. Conversations between supervisory personnel or maintenance personnel often monopolized the single channel during normal operations. In emergency situations, the system is not only channel limited but voice signal levels decrease as more phones are taken off hook.

*Reference to specific brands, equipment, or trade names in this report is made to facilitate understanding and does not imply endorsement by the Bureau of Mines.

Separate ac buzzer lines keep the buzzer levels from decreasing, but all signaling ceases if ac power is lost. The party line affords no privacy for supervisory communication. A panic could result if misinformation were overheard. A party-line system can cause delays in implementing corrective actions, and can result in additional complications. The need for increased underground telephone capability was evident.

3.3 Emergency Alerting System and Backup Communication

The mine compressed air system is used in a conventional stench warning system to notify all underground personnel of an emergency situation. Methyl mercaptan ("rotten cabbage" smell) odor is introduced into the compressed air system at the surface when an emergency is detected.

It takes approximately 15 to 30 minutes (or longer) for the stench to reach all areas of the mine complex. A preplanned course of action is taken by everyone underground when the stench is detected. All personnel are instructed to report to designated rescue areas, shaft stations, or other gathering points. These areas are provided with an underground party-line telephone. Because of the telephone's vulnerability to overloading and the possible loss of ac power during an emergency situation, a more reliable emergency communication system was needed for these points.

3.4 Fan and Pump Monitoring

Power inputs to the main ventilation fans on the 3100 and 3700 level are monitored on a go/no-go basis. Power input to the pumps on the 1700, 2700, 3700, and 4000 levels of the Jewell shaft are also monitored on a go/no-go basis. Alarm information is supplied to the Jewell hoist on the surface via a dedicated hardware pair (actually a common ground is used for each four- to six-monitor points to save wire). The hoistman on duty takes appropriate action as dictated by company policy.

The monitoring of pumps and fans on the various levels of the No. 10 shaft is accomplished in a similar manner. All indicators and alarm information is displayed on a panel in the Blue Room area (a gathering point for supervisors and other miners). The miners present take the appropriate action as dictated by company policy.

This system could be considerably improved if the monitoring information from both the No. 10 shaft area and the Jewell shaft area could be displayed at a central point on the surface. Monitoring of fire doors was also desired but was not possible due to the limited number of wire pairs in the shaft. The requirement of adding new cables to the shaft, when expanded monitoring capability is desired, is a major problem with the present system and should be avoided when the present system is replaced.

3.5 Environmental Monitoring

The carbon monoxide sensor installed at the 1900 level was removed because calibration and maintenance required too much effort.

Carbon monoxide sensing is still desired if a sensor can be obtained that requires less care and provides a surface display.

3.6 Muck Pocket Communications

To function efficiently, constant communication is required between the hoistman and the cager while he is in the muck pocket. To satisfy this requirement, Sunshine provided a pair of wires and a party-line telephone to the muck pocket. The maintenance required on both the telephones and wiring was considerable and it was concluded that any type of wire-line solution would be unacceptable. This ruled out the feasibility of placing a subscriber station from the carrier-based phone system.

An alternate plan to achieve two-way wireless communications was forwarded to the USBM Technical Project Officer. The alternative plan required the design and fabrication of a unit to serve as an interface between a portable belt-carried uhf transceiver and the Rockwell-Collins hoist radio system. The unit would provide VOX control of the cage-mounted hoist transceiver and serve as an extension to the fixed transceiver in operation. This would permit the cager in the muck pocket to be in constant contact with the hoist operator or the shaft station, while on a cage level different from the level on which the hoist transceiver is mounted. This approach would solve the recurring problem of providing a durable extension to the hoist communication system during shaft inspection and maintenance and would serve as an emergency system for communication in the vicinity of the shaft area. Due to the involved and extensive development, this approach fell outside the scope of the Sunshine project as it was defined at that time. This method for muck pocket communications was deleted from the proposed communication improvements.

4.0 SOLUTION AND EQUIPMENT DESCRIPTION

Adequate communications within a mine and to the surface is a vital part of the proper operation of an underground facility. This communications capability is not only an important factor in the concept of safety precautions, but is valuable in day-to-day operations. Careful selection of machinery and underground environment for monitoring will result in improved safety and productivity. Prior knowledge of situations which present potential problems will result in early solutions, and in a savings of man-hours and dollars. Efficient environmental and machine monitoring is one key to safer and more productive underground mining.

4.1 Contract Brief

The problems associated with the communications and monitoring systems (or lack thereof) in the Sunshine Mine were described in paragraph 3.0, Statement of the Problem. The planned solutions as stated under provisions of the USBM Engineering and Administrative Services Contract S0133035 were implemented in accordance with the following 8-phase program:

a. Communication Survey

1. Determine the communication and monitoring requirements for the Sunshine Mine in conjunction with the USBM Technical Project Officer (TPO) via site surveys and interviews with mine personnel.
2. Provide an itemized list of the communication and monitoring requirements and submit this list to the USBM TPO.

b. Whole Mine Communication Monitoring System

1. Prepare drawings showing equipment selection, location, and installation details and submit to the TPO.
2. Prepare a final technical report on the recommended systems and solutions to the approved list of communication and monitoring requirements.
3. Prepare system block diagrams and lists of materials for installation at the Sunshine Mine.
4. Review equipment locations and installation details with mine personnel.
5. Coordinate USBM purchase of all recommended equipments.

c. Prepare Equipment Procurement

1. Write specifications for each equipment and subsystem to serve as procurement documents.
2. Prepare procurement lists and submit to TPO.
3. Assist USBM in procuring recommended equipment.

d. Equipment Acceptance

1. Prepare "Inspection Checklist" to serve as a guide for receiving equipment and components purchased.
2. Perform incoming inspection on all equipments upon arrival at Rockwell-Collins, Cedar Rapids, Iowa.
3. Prepare a "Calibration and Test Checklist" using specifications and manufacturers information.
4. Perform initial electrical tests on equipment as it is received, and document the results.

5. Assemble subsystems.
6. Calibrate and align all equipment.
7. Review test reports for inclusion into a permanent logbook record.
8. Perform final systems integration tests to ensure that all subsystems have been interconnected correctly.
9. Demonstrate final system tests to the USBM TPO using test facilities at Rockwell-Collins, Cedar Rapids, Iowa.

e. System Installation

1. Review installation plans with mine and USBM personnel.
2. Ship all subsystems to the mine.
3. Assist the mine in installing the systems.

f. Maintenance Training Program

1. Prepare an operation and maintenance training program for mine personnel.
2. Conduct sessions at the mine on minor repair and routine maintenance of all equipment installed.
3. Coordinate attendance of technicians from the mine and manufacturer's schools.
4. Review system operation and maintenance problems and recommend corrective action.

g. Make System Operational

1. Prepare a systems logbook to be used by mine personnel for recording systems maintenance.
2. Identify test points for the systems in a manner and format consistent with the logbook.
3. Determine acceptable test limits and methods for routine maintenance of equipment.
4. Prepare a test plan and coordinate a schedule for a system operation demonstration.
5. Perform acceptance tests, and demonstrate systems to USBM and mine personnel.

h. Field Support and Modification

1. Provide follow-on support as required to modify and maintain the system after acceptance of the installation.
2. Document modifications performed and periodic systems tests.

4.2 Survey Results

Results from the communication and monitoring survey conducted at the Sunshine Mine indicated a need for new or improved communications and monitoring capability in the following areas:

a. Hoist Communications

Two-way voice communications between the cage and the hoist room should be provided to improve the coordination between cager and hoistman, and improve safety of the hoisting operation.

- b. Voice communications from deep in the mine to the surface. An improved system was needed to satisfy the following requirements:
 - 1. Provide multiple voice paths allowing confidential conversations between selected points underground and the surface.
 - 2. Allow true selective signaling to alert only the phone desired. This provides a degree of confidentiality to party lines.
 - 3. Utilize existing cable installed in the mine to the greatest extent possible to minimize or avoid additional cable installation in the shafts.

- c. Emergency backup communications from refuge areas, shaft stations, and other probable gathering points. The recommended configuration would satisfy the following requirements:
 - 1. Provide fully functional communications during peak usage periods directly after a primary power failure.
 - 2. Provide emergency backup communications from refuge areas, shaft stations, and other probable gathering points for a 24-hour time period during rescue operations.
 - 3. Provide communications from the Blue Room and underground hoist rooms to the surface for an extended period of time during an emergency. (Requires an additional line to the surface.)
 - 4. The emergency system should be checked periodically or used on a daily basis to ensure that it will be operational when needed.

- d. Additional monitor and control capability to the surface. An improved system would incorporate the following features:
 - 1. Expanded transmission capability, allowing access to functions mine-wide.
 - 2. Provide both digital and analog monitoring capabilities.
 - 3. Provide limited control capabilities.
 - 4. Allow monitoring, display, and supervisory control capabilities from multiple locations.
 - 5. Allow expansion to accommodate mine growth and change.

- e. Environmental monitoring (carbon monoxide)

An improved system would display sensor data on the surface. Ideally, it would operate on an existing telephone system twisted pair. Sensor maintenance would be kept to a minimum.

- f. Voice communication to the hoist operator from cager in muck pockets.

- g. Paging or call-alert capability for key personnel or to miners in remote areas. This system should be able to quickly alert specific personnel.

4.3 Hardware Implementation

The objective of this program is to furnish a multichannel mine telephone system which minimizes the installation of new wiring, provides improved two-way communications between the hoistman and the cager on both the Jewell and No. 10 chippy hoists, and implements additional monitor and control capability from deep within the mine to the surface.

The system selected to fulfill the requirements of the Sunshine Mine consists of the following: a carrier telephone system that uses commercially available telephone equipment, an inductive hoist communication system (refer to figure 4-1) developed for the United States Bureau of Mines, and a commercially available status monitoring and supervisory control system that uses a single audio grade circuit for data transmission. A description of these systems and their installation is discussed in the following paragraphs.

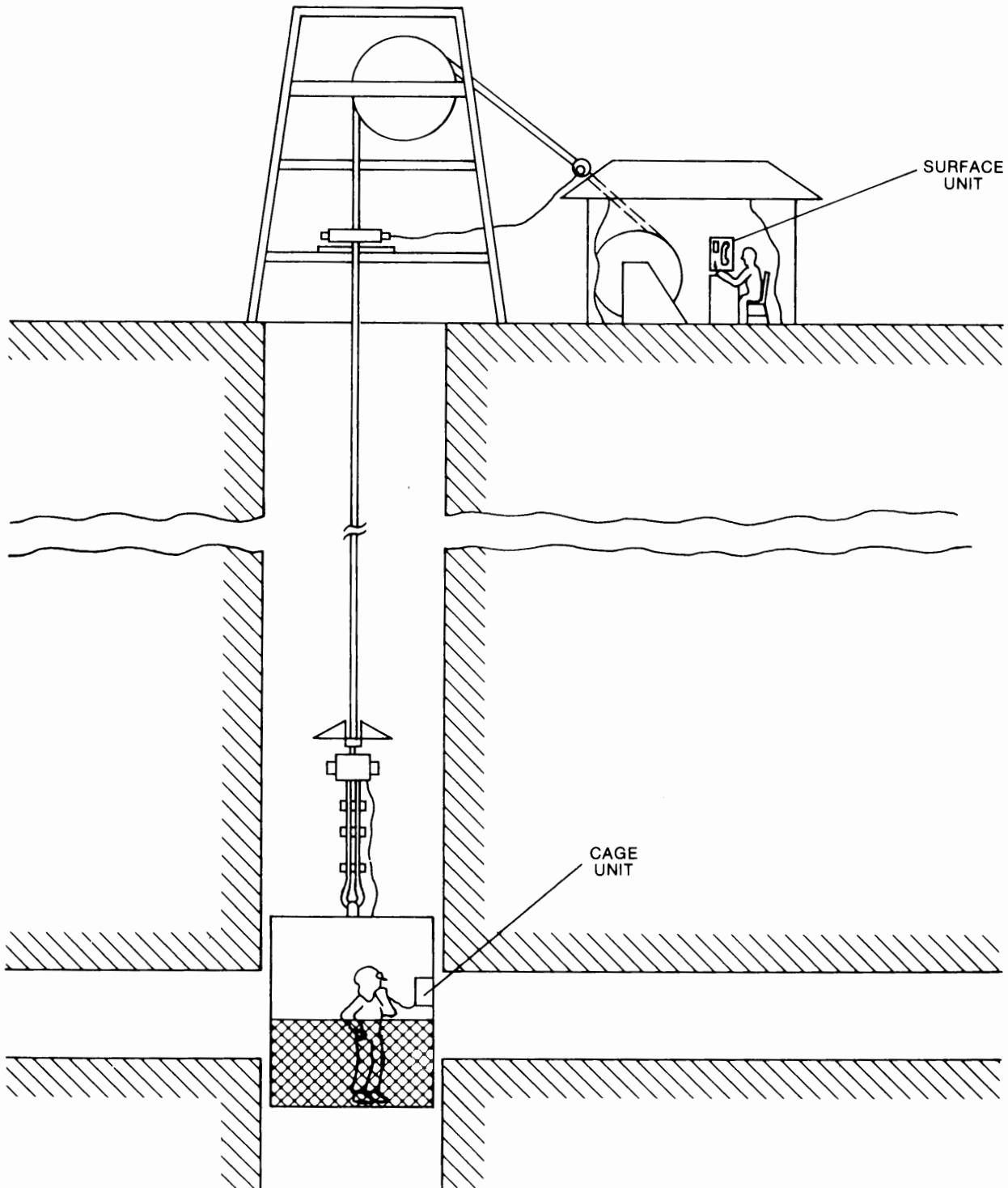

Figure 4-1. Hoist Communications System.

4.4 Hoist Communications

An improved inductive hoist communications system was developed for the USBM under contract H0357148. The communication system was designed to provide reliable voice communications between the hoist operator and the hoist cage at all levels down to 10,000 feet. Figure 4-2 shows a block diagram of the hoist radio hardware used in a shaft. The system consists of two couplers and two transceivers. Each unit is of the push-to-talk, release-to-listen design. During transmission, the sending unit feeds the coupler with a frequency-modulated (FM) carrier at 52 kilohertz (kHz). The coupler induces a signal in the rope-shaft structure, which is then picked up by the coupler of the second unit. Both couplers are electrically identical, and each operates both as a transmitting and receiving element. Tests at several shafts have shown that signal losses at 52 kHz are small, and standing wave effects, which cause signal fade, are negligible. This resulted in high-quality voice transmission at all levels in the shaft. The most important feature of the design is the signal coupler which was designed to achieve maximum signal level for a given transmitter power output.

First generation versions of this hoist communication system were installed in the Lucky Friday Mine in Mullan, Idaho, and the Grace Mine in Morgantown, Pennsylvania. The results of both installations were encouraging. Two of the second-generation systems were installed in the Sunshine Mine.

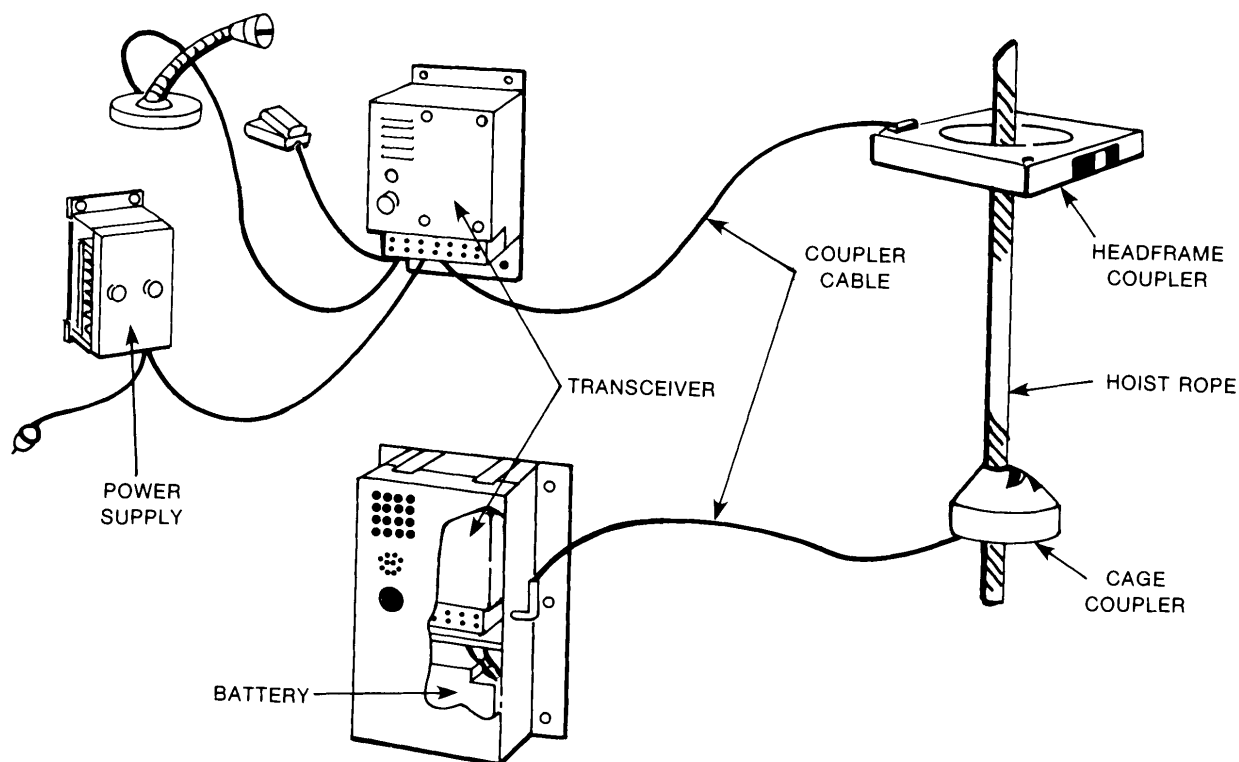

Figure 4-2. Block Diagram Showing Transceivers, Couplers, and Rope.

4.4.1 Hardware Description

Figure 4-3 shows the HCS-103 Hoist Communication System hardware. The hoist room station equipment is shown on the right and consists of a transceiver, battery charger with internal battery, foot operated push-to-talk switch, boom microphone, and surface (headframe) coupler. The cage equipment is shown on the left and consists of a transceiver, protective enclosure, internal battery, and underground (cage) coupler. Figure 4-4 shows the cage transceiver and battery mounted in the protective enclosure.

A durable protective enclosure is fabricated from angle iron which protects the transceiver from the continual abuse it receives from loading and unloading timber, drill rods, and similar material being transported underground in a man-material cage. This protective enclosure houses both the transceiver and battery in a compact, rugged unit that can be easily and quickly installed in the cage. When the transceiver is mounted in small cages where space is at a premium, the unit may be recessed in the cage wall without the protective enclosure, and the battery may be installed either above or below the cage.

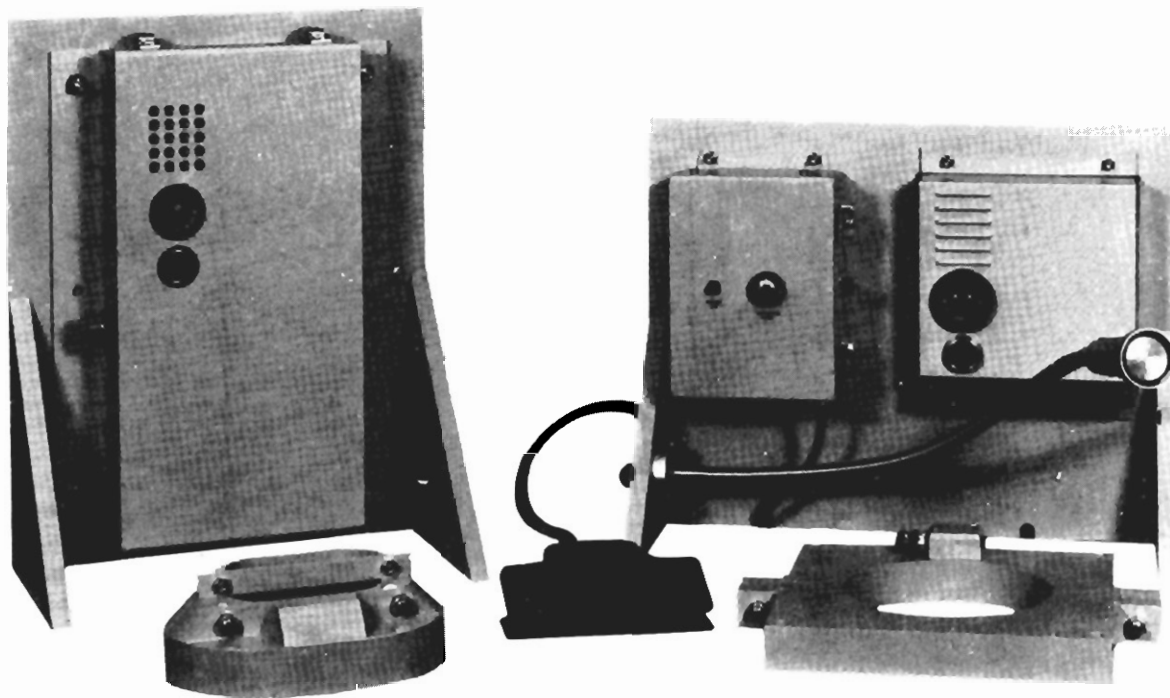

Figure 4-3. HCS-103 Hoist Communications System.

The noise-canceling microphone, push-to-talk switch, and moisture-resistant speaker are mounted on the front panel of the unit. Provision is made for attaching a remote speaker for use in multideck cages. An ordinary lead-acid, motorcycle-type battery provides backup power during periods of main power failure. The battery is readily available locally or from mail-order catalogs. Battery life is at least 7 days.



Figure 4-4. Cage Transceiver and Battery as Mounted in Protective Enclosure.

All terminals on the cage unit are screw-type barrier strips for ease of installation. Threaded knockouts are provided on the protective enclosure for conduit. A remote handset input is available on the transceiver for use during shaft inspection and maintenance. Input terminals for a slack-rope-alarm switch are provided on the transceiver. The alarm signals the hoistman with an intermittent beep if the rope becomes slack, either intentionally or unintentionally. Normal voice communication is possible with the alarm signals. In addition to the slack-rope signal, an in-cage belling signal is provided. A bell-bottle switch wired to this input is used to signal the hoistman in the same manner that a pull bottle is used in a conventional shaft station.

The hoistman's transceiver is identical to the cage equipment except that the protective enclosure is not necessary for the surface installation. A combined power supply and battery charger powers the hoistman's unit and charges the spare hoist battery, which is changed once a week.

A foot-operated, push-to-talk switch located beneath the hoist console is the only operating control necessary. The hoistman is also provided with a noise-canceling boom microphone, which is positioned for convenience.

4.4.2 Installation

Two HCS-103 Hoist Communications Systems were procured from Rockwell-Collins by the USBM under contract number H0357148. The hoist communication systems were shipped directly to Sunshine Mine in April 1976.

A survey trip was made to the mine four months before actual installation to gather specific details concerning equipment locations. All equipment sites were visited and photographed for future reference. The mine was provided with a list of their materials and manpower requirements. With this information, the mine could gather the necessary equipment and install wire from the hoist room to sheave wheel, thus facilitating the actual hoist communication system installation.

The miners at Sunshine went on strike in March 1976. This had a beneficial impact on the installation of the hoist communication systems since access to the cages was better during a strike period. The hoist radio systems were installed on both the Jewell and No. 10 hoists in May 1976.

The transceiver and battery were mounted in their protective enclosures on the lower deck of both the Jewell and No. 10 chippy hoists (figure 4-5). Wiring between the transceiver, coupler, and remote handset was enclosed in a 1-inch steel pipe with flexible conduit connecting the pipe between cages (figure 4-6). The cage was also fitted with a slack-rope alarm wired to the transceiver.

The remote handset jack was located on top of the cage. This extension was constructed by adding a "T" fitting in the cable pipe and



Figure 4-5. Cage Installation at Sunshine Mine.

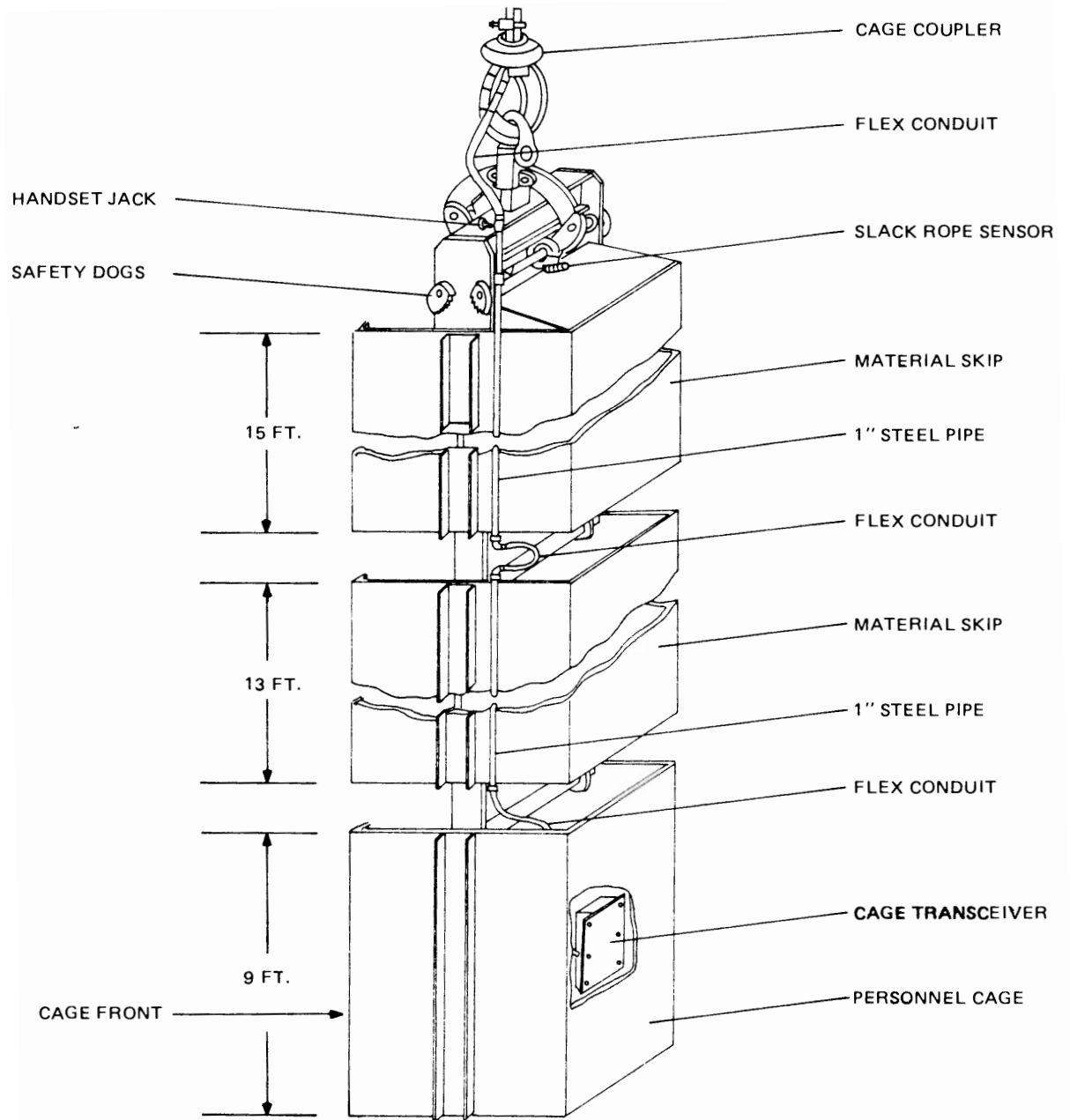

TP5-6722-011

Figure 4-6. Sunshine Mine Cage Installation Wiring.

fitting the pipe stub with a multipin twist-lock connector. The connector was wired and attached into the end of the pipe stub using an epoxy adhesive. A pipe cap provides protection against the environment when the unit is not in use.

Figure 4-7 shows the remote handset in use during shaft inspection. The elliptical cage coupler was mounted on the hoist rope using a built-in clamp. Shielded twisted pair cable, provided by Sunshine Mine, was used to interconnect the coupler and cage transceiver.

An in-cage belling system was installed on the Jewell hoist several months after the initial system installation. This system used an extra pair of wires which were connected across the slack-rope-alarm inputs and a standard mine pull-bottle (figure 4-8).

Sunshine then installed the system on the No. 10 chippy. Figure 4-9 shows the in-cage belling option used to signal the hoistman.



Figure 4-7. Shaft Inspection.

The hoist room transceivers were mounted in the chippy hoistrooms on the cab walls. A boom (gooseneck) microphone and foot-operated, push-to-talk switch were incorporated into the hoist stations (figure 4-10). The dynamic boom microphone in the Jewell hoist room was replaced with a noise-canceling unit due to the large amount of background noise in that area.

The Jewell transceivers power supply/battery charger was mounted in the basement beneath the hoistman's console. The power supply/battery charger for the No. 10 hoist room transceiver was mounted on a shelf behind the hoist operations cab. All interconnections between transceivers and power supplies were made with stranded electrical cable provided by Sunshine Mine. Shielded twisted pair cable was used to interconnect the transceivers to sheave wheel couplers on both systems (figure 4-11).

Both the Jewell and No. 10 shaft hoist communication systems were installed in five days. Much of this time was spent waiting for the cage to become available as the cages were used frequently by supervisory personnel for inspections and shaft repair during the strike. The voice communication and in-cage belling features were demonstrated and the slack-rope-alarm feature was explained to the miners.

Both hoist communication systems were bench tested by Rockwell-Collins personnel at Sunshine before installation. The systems were tested again after installation by USBM, Sunshine, and Rockwell-Collins personnel. The final talk-through and operational tests were conducted by Sunshine Mine personnel with no assistance being required.

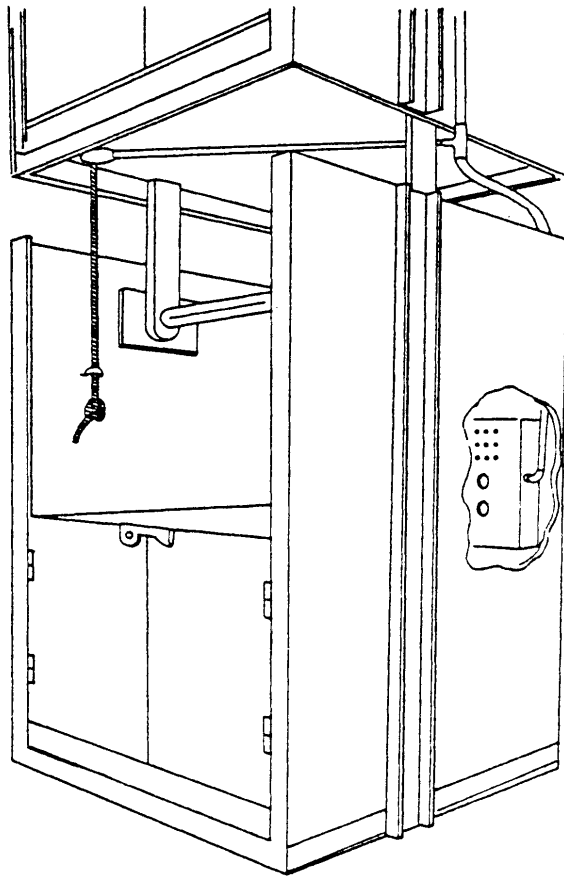

TP5-6718-011

Figure 4-8. In-Cage Belling Addition.



Figure 4-9. In-Cage Belling Operation.

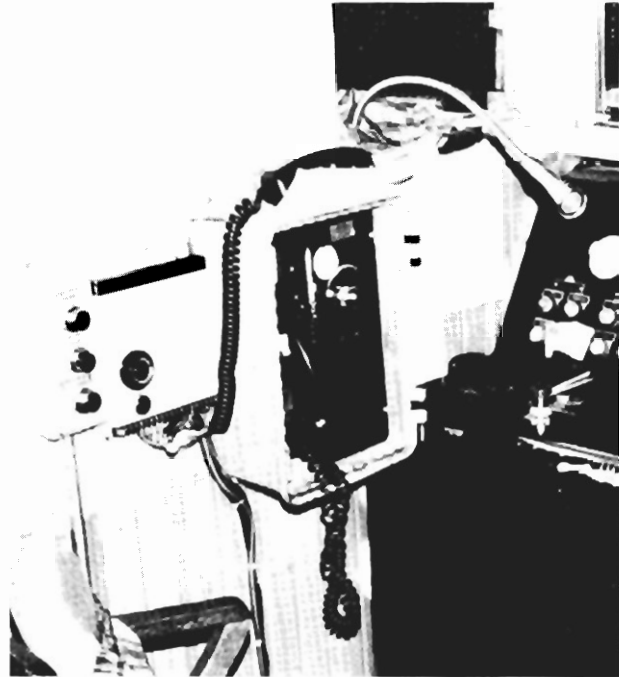

Figure 4-10. Jewell Chippy Hoist Room Installation.



Figure 4-11. Sheave Wheel Coupler.

4.4.3 Follow-On Maintenance and Support

Mine personnel were provided with a spare transceiver, battery charger, and couplers to assist them with system maintenance. In addition, interconnect diagrams, operational descriptions, and technical manuals were provided. Two handsets with twist-lock connectors were supplied for use during shaft inspections. The transceiver was removed and replaced with a charged battery. Approximately 5 minutes is required to remove and replace it in its hinged enclosure (figure 4-12).

Two months after installation, mine personnel complained that the voice of the hoistman was unreadable by persons on the Jewell cage. Consequently, the transceiver on the Jewell cage was replaced by Rockwell-Collins and Sunshine personnel. Inspection revealed that the waterproof speaker in the malfunctioning unit was defective. The speaker was replaced and the unit returned to service. There were no major problems with the Jewell system during the 18 months following the repair of the transceiver.

The No. 10 chippy system was required to operate under harsher environmental conditions. Broken wiring, even when protected in flexible conduit, was a major problem. The wiring between the coupler and cage transceiver was severed by shaft debris 2 months after installation. Reconnection of this wiring by Sunshine and Rockwell-Collins personnel restored the system to full service. The wiring to the coupler was then reconfigured by routing the flexible conduit to the cage coupler, below the hurricane deck, to alleviate problems with shaft debris. On another occasion, all cage wiring was accidentally torn out when a deck was removed.

The wiring between the sheave wheel and the hoist room transceiver was also severed by shaft debris.

The entire No. 10 cage system is also subjected to a 100 percent humidity atmosphere containing large quantities of corrosive salts. The following problems were found with the hoist communication system as a result of operation in the No. 10 shaft:

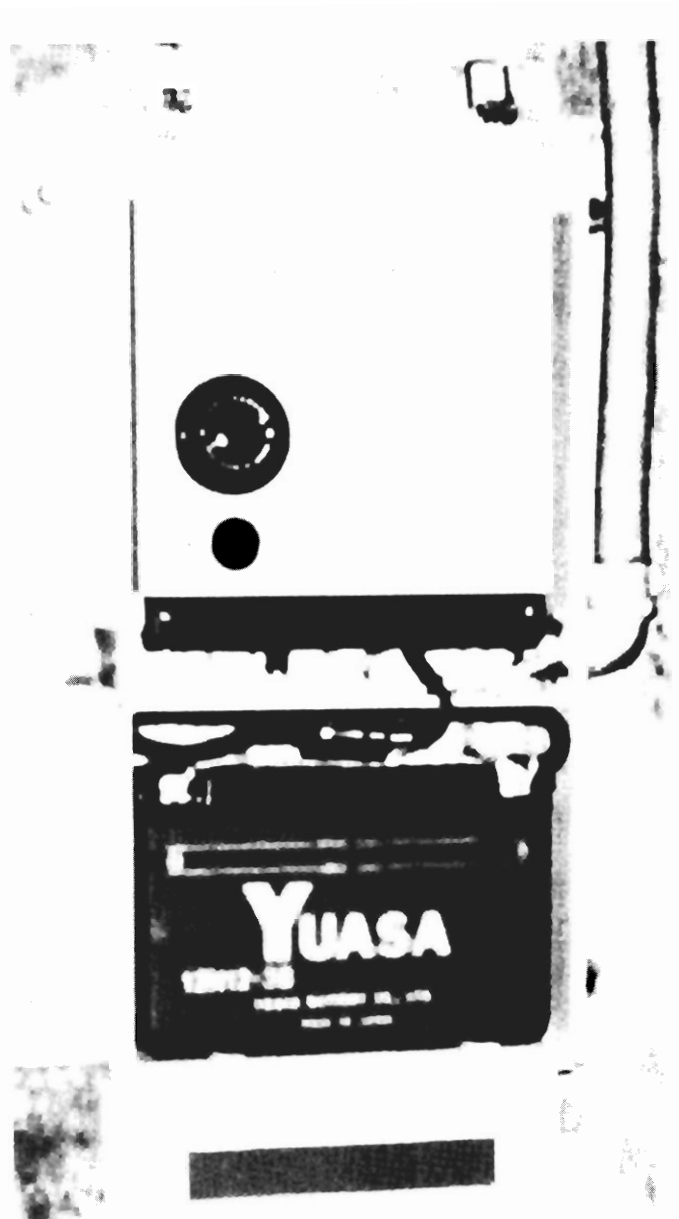

Figure 4-12. Open Cage Transceiver Shown.

- a. Transceiver push-to-talk switch failure. The large industrial contact switch, although rugged, was designed for 115 v ac. The contacts lacked the wiping action required to remain clean when used with small dc currents. A microswitch, mounted behind the large button, solved this problem.
- b. Corrosion of transceiver connector contacts. The protective enclosure was a covered frame which mounted the transceiver and battery against the cage wall. The cage wall is rusty and continually wet. This water and rust ran into the transceiver and collected on the shelf next to the wire terminals causing excessive corrosion and signal level losses. Sunshine personnel fabricated a rack for the enclosure. This resulted in a much cleaner contact area. The remaining corrosion problems were corrected by spraying the contacts with contact cleaner and wiping the area clean during weekly battery replacement.
- c. Battery charger failures. The No. 10 system battery charger began overcharging the batteries. The unit had a shorted transistor. Similar failures had occurred on this charger when installed on the Colvin Hoist System at the Robena Mine in Pennsylvania. Analysis revealed that the power supply was not folding back at 1.5 amperes as specified by the vendor but would current limit at 2.2 to 2.5 amperes. This resulted in overheating and subsequent failure of the pass transistor when charging the transceiver batteries. The problem was corrected by replacing the limiter resistor with a value which would limit current at 1.5 amperes.
- d. Deterioration of microphone on transceiver. This had been a problem on previous hoist communication systems. The carbon noise-canceling units were the most corrosion-resistant units available and their performance was quite acceptable with periodic replacement. The No. 10 cage atmosphere is more corrosive and wet than in any previous installations. Microphone failure occurred within 1 month. Analysis at Rockwell-Collins revealed that failures were caused by corrosion within the microphone. Water and corrosive elements were entering two holes on the side of the microphone that provides additional noise-canceling properties. The holes were filled with a silicon rubber sealant and the microphone was tested for the effects of this modification on the noise-canceling properties. The modified microphone exhibited only slightly less noise canceling than the original microphone. The microphone on the No. 10 cage transceiver was replaced with the modified unit. Results have been encouraging. This modification extends the life of the microphone to over 1 month. Monthly replacement of the unit has been determined to be an acceptable maintenance requirement. The Sunshine Mine has also installed a rubber flap over the transceiver to keep water from directly falling on the unit. This modification has also extended the life of the microphone.

The remote handset is no longer used on the No. 10 chippy hoist because of excessive wiring maintenance requirements. With the exception of failures due to shaft debris as in the fall of 1977, the No. 10 chippy system has provided acceptable service since May 1977. The Jewell chippy system provides excellent service since installation in May 1976.

The Sunshine miners returned to work in March 1977. Three electricians received training in the operation, troubleshooting, and testing of the hoist communication systems that summer. The results have been quite successful. Since August 1977, all maintenance on the Jewell system has been performed by Sunshine personnel. After accidentally tearing out the cage wiring when removing a deck, Sunshine electricians completely rewired and reinstalled the No. 10 cage system without assistance from Rockwell-Collins or the USBM.

A set of system-performance measurements were made prior to installation, and again 2 months and 18 months after installation to verify that both systems continued to operate properly. These measurements are listed in paragraph 5.3.

4.5 Carrier Communication System

A carrier telephone system was selected to satisfy the need for more than one simultaneous conversation, confidential conversations, selective ringing, and to minimize cable installation. The weatherized telephones, modified to include a loud Klaxon and quick-connect terminals, were placed at critical underground locations, such as shaft stations and shop areas. The system's primary switching functions were accomplished using a PBX centrally located in the Rock Burst monitor room on the level near the No. 10 shaft area. This minimized wiring and provided a dual communication path to the surface. To further minimize wiring, 2 carrier systems and 10 intercom units were installed. One carrier system provides communications on the No. 10 shaft, the other system provides service to the Jewell shaft and to the surface. The intercoms have a common audio bus and allow selective signaling to all telephones on that intercom. All telephones on an intercom are also able to access or be accessed by the PBX, allowing selective signaling to any telephone in the system. Up to 8 (or 17) telephones can be connected to an intercom; both the intercoms and telephones are connected to the central PBX by a twisted wire pair or via the carrier system. During a power failure, the central equipment can operate for 72 hours (3 days), and the intercoms are provided with 24 hours of battery backup. The engineering design goal was to use off-the-shelf, readily available communications equipment and installation hardware. The system had to be compatible with the installation and maintenance capabilities of the mine maintenance personnel.

Through a cooperative agreement between the Sunshine Mining Company and the United States Bureau of Mines and under provisions of USBM contract S0133035, the communication system was developed and installed as previously described. Under provisions of this contract, Collins Commercial Telecommunications Division, Rockwell International, provided the technical expertise to design, package, and test the system at Cedar Rapids. The PBX, carrier system, and intercoms were assembled as subsystems and subjected to several months of burn-in and testing prior to shipment to Sunshine. This procedure detected faulty components and eliminated the frustrations of troubleshooting and testing the system underground.

4.5.1 System Operation

The central switching center for the system is located in the Rock Burst monitor room on the 3700 level near the No. 10 shaft. The intercoms are connected to carrier system subscriber drops and provide a party-line audio circuit. The operation of the carrier system is completely transparent, that is, the telephone user cannot tell if the intercom is directly connected to the PBX using a dedicated wire pair or the carrier system. The carrier system receives PBX line circuit signaling on a carrier channel input and duplicates them on that channel output (or subscriber drop). The signaling and off-hook functions of the telephone (or intercom) on a subscriber drop are also duplicated at the central office of the carrier system on the associated PBX line circuit. Intercoms and telephones may be directly connected to the PBX. The carrier system serves as a substitute for additional wire pairs (refer to figure 4-13).

A 2-digit number system is used for signaling from one PBX line circuit to another so that calls from telephones connected directly to the PBX are completed by dialing only these two digits. The call procedure in this case is similar to that used in many small motel PBX's. The procedure is as follows:

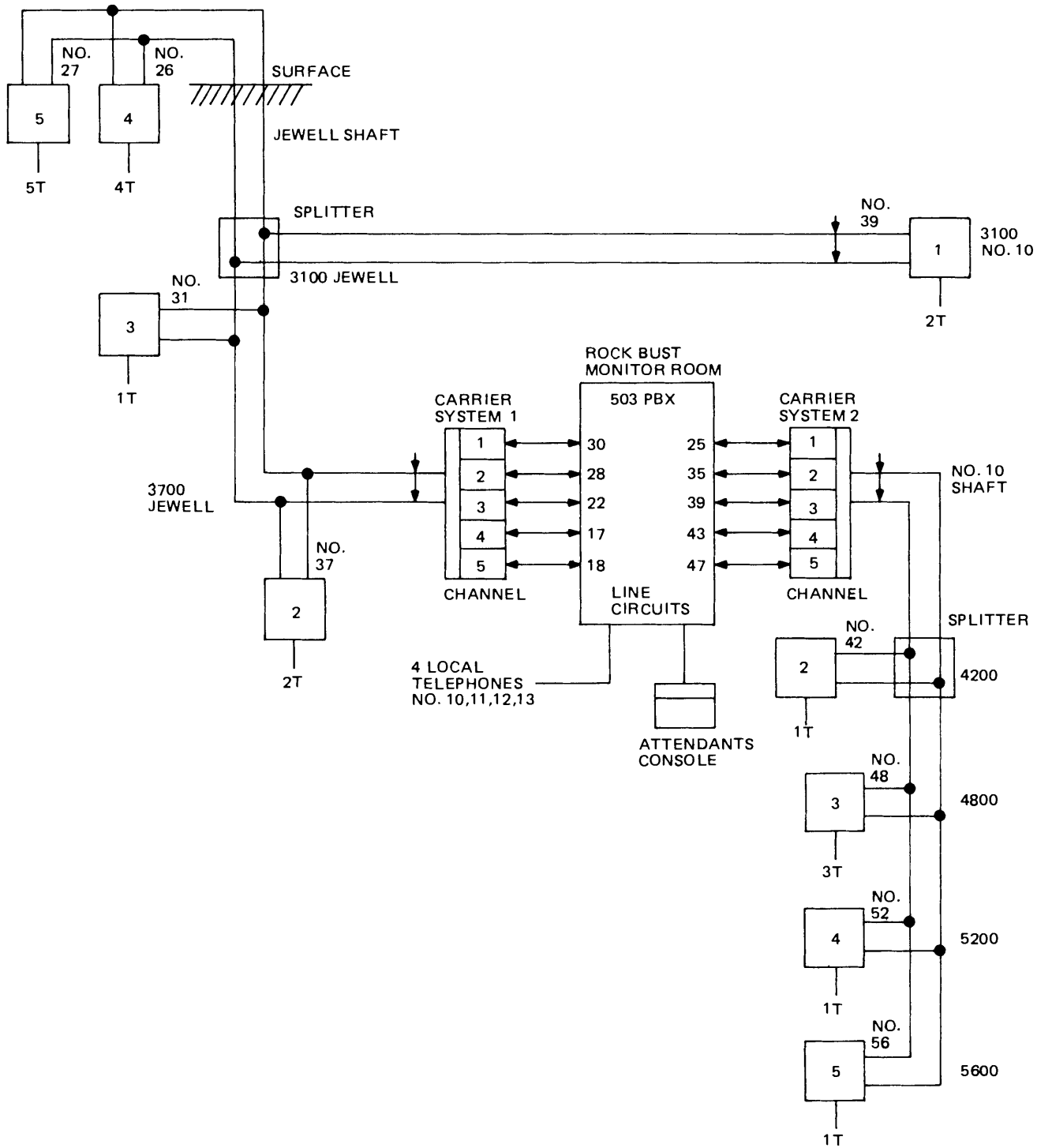

TP5-6720-011

Figure 4-13. Sunshine Mine Carrier Communications System, Block Diagram.

- a. The user initiates a call by going off hook at station A. A current loop is completed in the PBX line circuit and the PBX 400-Hz dial tone is received.
- b. The caller then dials the 2-digit number for station B, the called telephone.
- c. If station B is off hook, a busy tone is generated and the call cannot be completed at this time.
- d. If station B is on hook, ringback tone is given to the caller station A, and ringing signal (20 Hz, 90 v rms) is placed on line circuit B. When station B goes off hook, ringback tone and ringing cease and the two parties are connected.

The intercoms are connected to the PBX line circuits much the same as regular telephones, except that lines are not required for the 24 v dc signaling of the Klaxons. The intercom is assigned the 2-digit station number of the line circuit on which it has been installed. The intercom appears identical to other telephones as far as PBX signaling is concerned.

4.5.1.1 PBX-to-Intercom Call Procedure

The actual call procedure from a PBX phone to an intercom station telephone is as follows:

NOTE

This procedure is identical to the procedure for calls between two PBX phones.

- a. The caller dials the 2-digit number associated with the intercom to be called.
- b. If a busy tone is generated, the call cannot be completed at this time. (The intercom is off hook to the PBX, and a conversation has been established between a phone on that intercom and another telephone within the system.)
- c. If the intercom is not busy, ringback tone may or may not be given to the caller before the intercom detects the ringing voltage and comes off hook to the PBX. A 1300-Hz intercom dial tone is placed on the line at that time.
- d. The PBX audio loop has been completed. All PBX signaling detectors have been taken off line and the PBX is in a normal conversation state. The caller then depresses the 1- or 2-digit code associated with the desired intercom telephone. This Dual Tone Multiple Frequency (DTMF) signal is detected by the intercom DTMF detector and causes the intercom to remove its dial tone from the audio bus and replace it with a ringback signal (1600 Hz, 2 seconds on, 4 seconds off). Ringing is also supplied to the selected intercom station phone.
- e. The call is established when the intercom telephone goes off hook. If the ringing intercom telephone is not answered between 160 and 200 seconds, the intercom will time out and go back on hook with the PBX. The call must then be placed again. This time-out period is adjustable and has been changed to 45 to 90 seconds on several intercom units.

4.5.1.2 Intercom-to-Intercom Call Procedure

Any intercom station telephone can place calls to other telephones on that intercom without accessing the PBX. The intercom acts much like an independent party-line PBX in this respect. Calls from one intercom telephone to another telephone on the same intercom are placed as follows:

- a. The calling telephone, station A, goes off hook and receives the intercom dial tone.
- b. Caller then dials the 1- or 2-digit number for the desired intercom telephone, station B. Ringback is given to station A, and a ringing signal is placed on station B.
- c. Ringback and ringing are removed when station B goes off hook and the call is established.

4.5.1.3 Intercom-to-PBX Call Procedure

An intercom station telephone may call telephones other than those on the same intercom by accessing the PBX. Accessing the PBX and other system telephones is accomplished as follows:

- a. The calling intercom phone, station A, goes off hook and receives intercom dial tone.
- b. Station A then dials the digit 9 to access the PBX. This causes the intercom to take its dial tone off the audio bus and go off hook to the PBX by completing a current loop. The PBX dial tone is then returned to the intercom station telephone.
- c. The intercom telephone can now call through the PBX as if it were directly connected to a line circuit. The calling procedure is the same as previously outlined for PBX telephones. Placing the intercom telephone, station A, back on hook causes the intercom to go on hook in reference to the PBX.
- d. If the called party does not answer within the time-out period of the intercom timing circuitry, the module will deenergize the holding relays. This causes the intercom to remove the current loop from the PBX, dropping the call. All ringing ceases and the intercom returns to the normal on-hook status. If the called party comes off hook before the time-out period, the time out is reset and the station telephone provides a holding function to keep the circuit energized. Conversation begins without a timing limit. The time-out period, normally supplied by the timing modules, is from 160 to 200 seconds, but may be changed to provide a shorter or longer time-out period.

The calling procedures outlined in previous paragraphs are the same, whether an intercom or telephone is hardwired to the PBX or connected to that line circuit via the carrier system, since the carrier system is electrically transparent. A mine telephone list is shown in figure 4-14. This list was formulated by Sunshine electricians and is displayed near every telephone in the system. The codes within blocks represent intercom units.

Each intercom unit has internal battery backup which allows operation of the intercom and the station telephones for 24 hours in the absence of 115-v ac power. The central office equipment (PBX and carrier system) is provided with an uninterruptible power system, consisting of a 200-amp charger; a 48-volt, 2184-ampere-hour battery bank; and a 5-kva inverter. 48-v dc power for the carrier system is supplied directly from the battery bank, while the PBX is powered by normal mine power through a transfer switch in the inverter. If mine power is removed, the PBX is switched to inverter power. During an emergency situation, the system is capable of operating the central office and PBX in excess of 72 hours (3 days).

4.5.2 Hardware Description

The telephone system consists of several basic subsystems. These are the PBX, the carrier system, intercoms, telephones, and interruptible power source. An operational description and illustration of each subsystem installed in the Sunshine mine are presented in this section.

PHONE CODE

SURFACE

ELECTRIC SHOP	9 -	26	- 1
MACHINE SHOP	9 -	26	- 2
WAREHOUSE	9 -	26	- 3
ENGINEERS	9 -	26	- 4
JEWELL TOP STATION	9 -	27	- 1
SHIFTERS SHACK	9 -	27	- 3
JEWELL SERVICE HOIST	9 -	27	- 4
JEWELL DB. DRM. HOIST	9 -	27	- 5
SAFETY OFFICE	9 -	27	- 6

UNDERGROUND

1700 JEWELL STATION	9 -	31	- 3
2700 JEWELL STATION	9 -	31	- 2
3100 JEWELL STATION	9 -	31	- 1
3700 JEWELL STATION	9 -	37	- 1
4800 No. 12 SHAFT	9 -	37	- 2
3100 No. 10 STATION	9 -	39	- 1
3100 No. 10 HOIST ROOM	9 -	39	- 2
3700 BLUE ROOM	9 -	10	
3700 No. 10 MACHINE SHOP	9 -	11	
3700 U.G. ELEC. SHOP	9 -	12	
3700 SERVICE HOIST	9 -	13	
4200 No. 10 STATION	9 -	42	- 1
4400 No. 10 STATION	9 -	42	- 2
4600 No. 10 STATION	9 -	48	- 2
4800 No. 10 STATION	9 -	48	- 1
5000 No. 10 STATION	9 -	48	- 3
5200 No. 10 STATION	9 -	52	- 1
5400 No. 10 STATION	9 -	52	- 2
5600 No. 10 STATION	9 -	56	- 1
5600 REFUGE CHAMBER	9 -	56	- 2

Calling within BLOCKED CODE NUMBER
use last digit only.

Calling elsewhere . . . use ALL NUMBERS.

Wait for 'HIGH' tone before punching last digit.

Figure 4-14. Sunshine Telephone Number List.

4.5.3 Private Branch Exchange (PBX)

The PBX circuits are housed in a cabinet with removable side panels, providing easy equipment access (refer to figure 4-15). The cabinet contains shelves for mounting the plug-in modules, a removable system status panel (removable from the front of the cabinet), and a quick-connect terminal assembly and class of service panel mounted behind the right side panel. The quick-connect terminal assembly and class of service are hinged on one side and may be swung out to gain access to interconnect wiring located behind shelf mounted assemblies. The equipment specifications and installation data are listed in paragraph 6.0.

The 503 PBX provides switching for up to 60 line stations (telephones). The unit can handle as many as 12 trunk lines. The actual number of cross-connections which can be made at any given time is 6 line-to-line connections plus an additional 12 line-to-trunk cross-connections. The Sunshine system does not utilize the trunks, and only six conversations are cross-connected through the Sunshine PBX.

Call processing on the PBX is divided into two parts: call origination and call termination. The call origination begins by a telephone going off hook, creating a service request. The service request marks an available register as busy and stores the originating service number. The register then sets a sequence counter to receive and store digits from the originating circuit. When the counter receives the first digit, a dial tone is returned. After the called number receives the first digit, the sequence advances and the dial tone turns off.

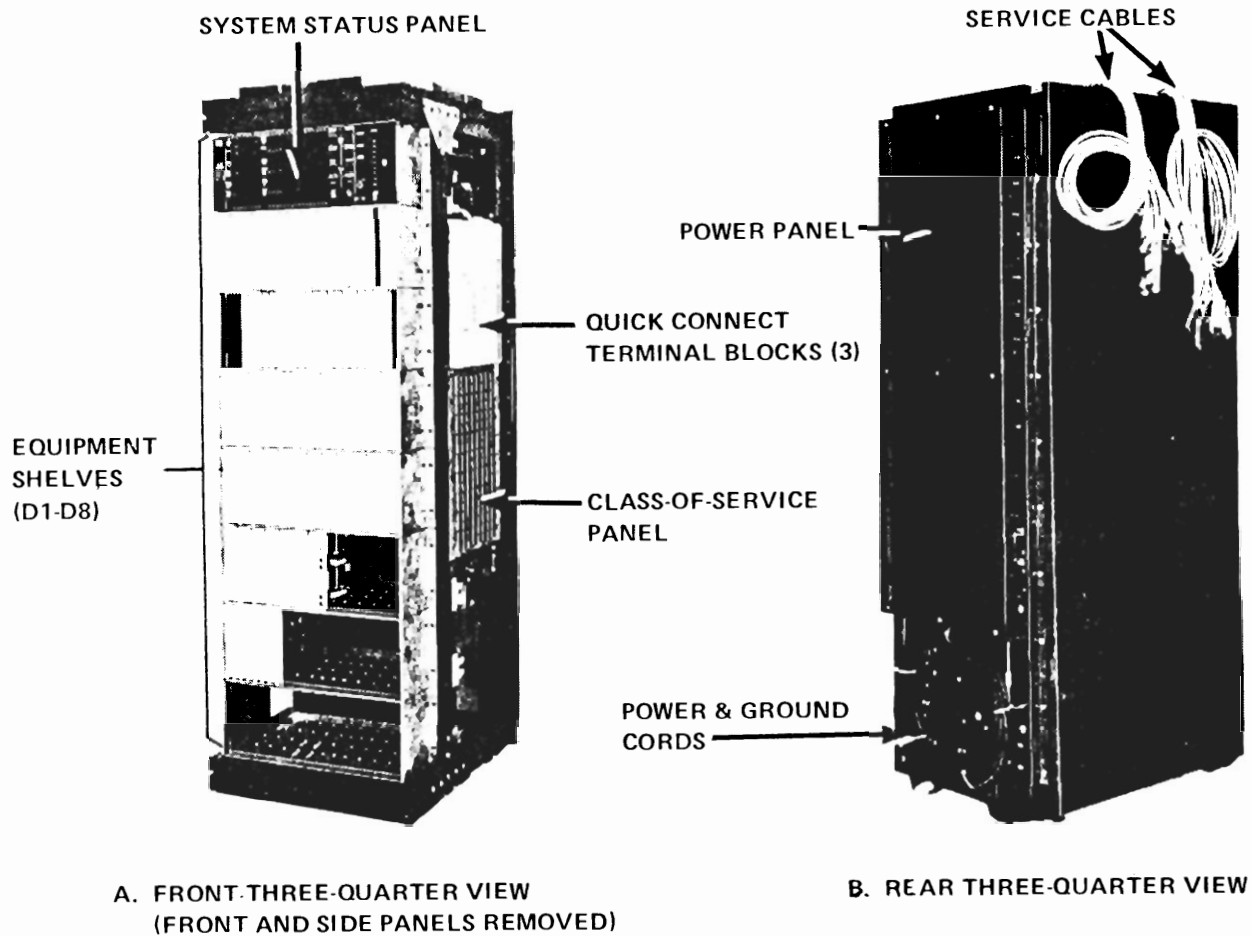

Figure 4-15. 503 PBX Cabinet.

The call termination begins when the controlling register has received both call digits from the originating circuit. The register then performs a check on the called station's circuit to determine if it is idle or busy. If the circuit is busy, a busy tone is sent to the calling telephone. If the called station is idle, the controlling register applies a ringing voltage to the called station and ringback tone to the calling station. A speech gate between the calling and called stations allows the caller to hear the ringback tone. The ringback tone is generated by the called station's circuitry. When the called station comes off hook, the ring voltage and ringback signal generated in the associated line circuit are disabled and conversation can proceed. The controlling register is then removed from the line and is available to handle other calls.

The PBX contains a system status panel (which displays the status of registers), and the originating and answer numbers during a call. A register can be taken out of service if it is defective or if calls can be forced upon a questionable register to determine call-processing capabilities. DTMF key sets and rotary dials can be checked against the number displays to assure that they are functioning correctly. The DTMF decoders in the PBX itself can be compared in the same manner. The status panel also contains a light emitting diode (LED) indicator for each power supply in the PBX and a 2-digit fault-code display. If a power supply fails, the appropriate LED lights on the panel. The fault display gives a coded readout of faults in the PBX. A list of these codes is given in paragraph 4.12, explaining the exact fault that has occurred and the printed circuit cards which may be causing the problem.

Several optional functions are available and can be added to the PBX as required. The Sunshine PBX functions include DTMF signaling capability, two trunk modules, paging, and code call.

4.5.4 Attendant's Console

The attendant's console (figure 4-16) requires five 25-pair cables for installation. The console is located near the PBX. The access number to the attendant's console in the Sunshine

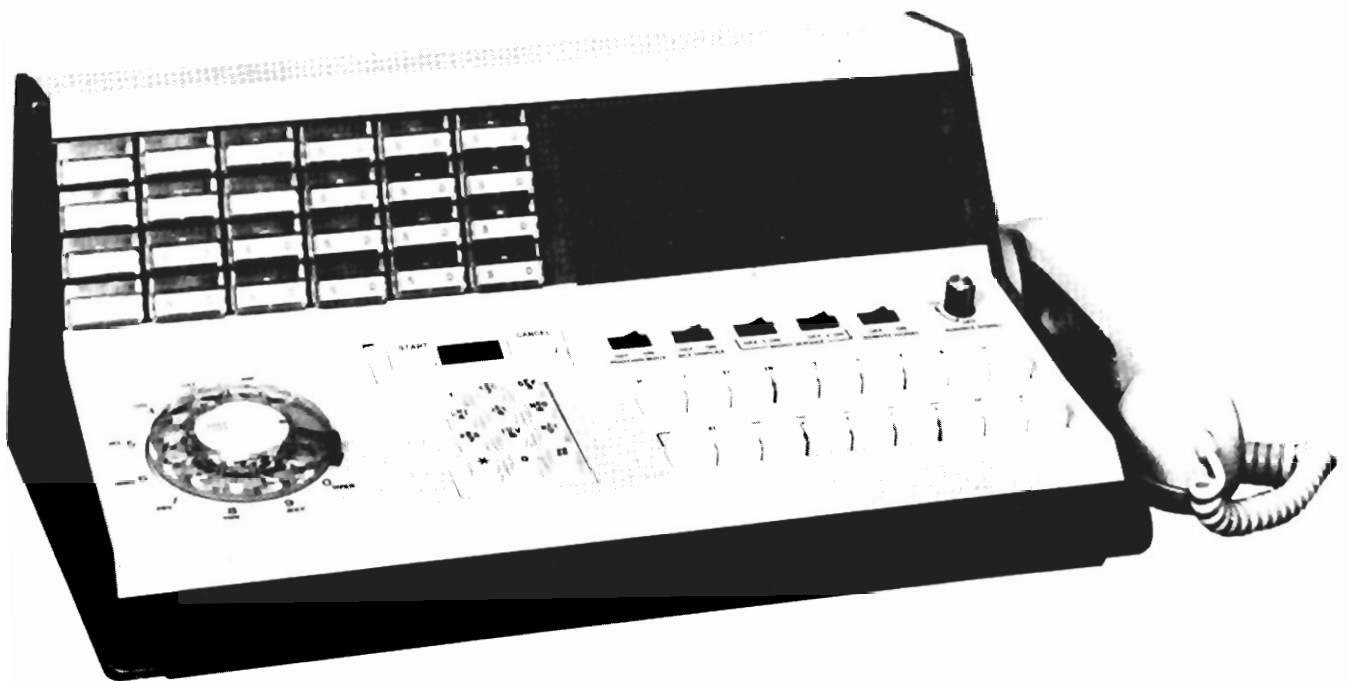

Figure 4-16. Attendant's Console and Busy Lamp Field.

installation is programmed for a single digit, 0. The console functions include busy override, truck control, attendants trunks, attendant line, hold key, and four special function keys. The busy lamp field displays a lighted number field for all busy stations on the system. The attendant's console also has an originating number display that identifies the station number of all lines that call the console. The attendant's console and busy lamp field were installed primarily as a system maintenance and operations center.

4.5.5 Anaconda S6A

The Anaconda S6A carrier system provides a multichannel communication link from deep in the mine to the surface. The S6A carrier system uses double-sideband amplitude-modulated carrier techniques to provide seven subscriber circuits over one wire pair by means of grouped carrier frequencies. Fourteen carrier frequencies are spaced at 8-kHz intervals (figure 4-17).

Subscriber-to-central office transmissions use frequencies below 60 kHz and central office-to-subscriber transmissions use frequencies above 60 kHz. These frequency allocations and their associated transmit levels are in accordance with industry standards for "station" class carriers.

The S6A carrier system consists of a central office terminal, seven subscriber terminals (one for each channel), and line treatment equipment. Line treatment equipment includes such items as repeaters, directional couplers, line termination units, matching transformers, isolation pads, ac isolation units, and remote power equipment. The S6A carrier systems using three repeaters or less require no adjustments because loss, ringing voltage, level coordination, and repeater slope compensation and gain are automatically controlled. Carrier and voice frequency levels are factory set and automatically maintained. Voice frequency net loss at 1 kHz is 4 db (± 2 db) in both directions of transmission. This meets all present transmission requirements. No special tools are required for maintaining the equipment. The S6A carrier system interfaces the PBX at conventional telephones, acting as a substitute for wire pairs. Voice and ringing signals from the PBX are received by the Anaconda central office terminals, where the carrier channel is modulated and transmitted to the subscriber. At the subscriber end, the signals are demodulated by a transceiver and restored to the original voice signal. Voice signals and dial pulses from the subscriber telephones are returned to the central office in the same manner.

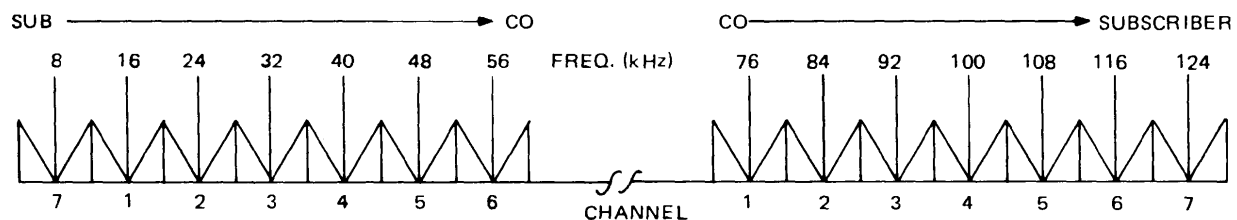

TP5-6715-011

Figure 4-17. S6A Channel Frequency Allocation.

Both Sunshine carrier system central offices are mounted in an Anaconda medium equipment cabinet with lockable doors. The central office terminal's interface wiring to the PBX is through the quick-connect terminal located above the PBX. Connections for carrier lines, input power, and carrier alarm points are located on a covered terminal board below the quick-connect block. The cabinet also houses a battery charger, batteries, and a 10-db audio bridge. The batteries and charger supply 24 v dc to operate the Klaxons on the PBX telephones. The audio bridge links two channels, one from each carrier system, to form a continuous audio pair from deep in the mine to the surface. This continuous channel is used as the monitoring/control system.

Each central office shelf contains seven transceiver cards (one for each channel used), a line driver card, and a dc converter or current limiter card (figure 4-18).

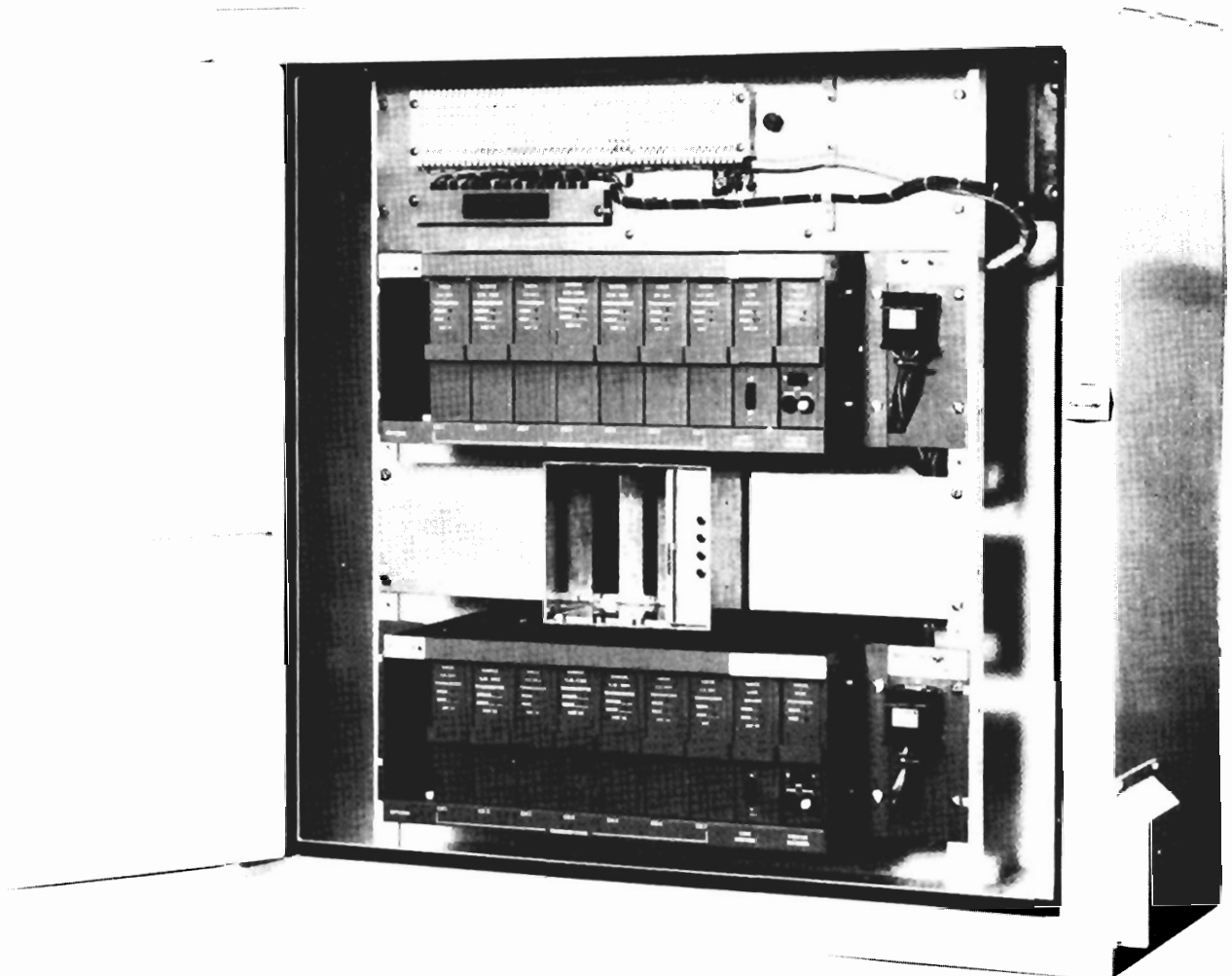

Figure 4-18. Sunshine Mine Carrier System Central Office.

The central office transceiver cards perform the transmit, receive, and filtering functions for the central office. The line driver, containing a bandpass filter, line amplifier, carrier line hybrid network, and an impedance matching network, supplies dc line voltage to the carrier line for powering repeaters and subscriber terminals. The dc converter provides 100 ma current limiting and converts the 48-v dc input to ± 96 v, ± 135 v, ± 150 v, or ± 165 v for powering the S6A remote station carrier equipment. The output voltage is selectable by a strapping arrangement. In the event of carrier line malfunction, the converter provides an alarm.

The S6A subscriber terminals connect the subscriber telephones or intercoms to the carrier line. The subscriber terminals are contained in single- or dual-terminal housings (figures 4-19 and 4-20).

Both single- and dual-subscriber drops contain a 6-volt battery which supplies the subscriber drop. The battery is continuously recharged from a power-supply circuit in the terminal. Power requirements for the terminal are obtained from the carrier line dc voltage. The subscriber terminal is protected from high-voltage surges by gas discharge tubes located on the chassis. Low-voltage protection is provided by zener diodes located on each card in the terminal.

Repeaters are required on the S6A system for every 35 db of cable loss. This loss increases as cable wire size decreases. For 19-gauge, twisted wire pair cable, the approximate spacing for repeaters is 5 miles. Since the longest length on the carrier system at Sunshine is 2 miles, repeaters are not required. Other line treatment equipment which was procured for the Sunshine system included: signal splitters to allow the carrier system to branch in two directions, line terminators, and ac isolation units to reduce ac induced on the carrier line.

The S6A station carrier equipment is designed for use in harsh environments. The central office equipment was specifically packaged for the Sunshine mine to allow ease of installation and troubleshooting. The standard subscriber drops and line equipment were suitable for installation in Sunshine as packaged. Specifications for the S6A station carrier system are given in paragraph 6.0.

4.6 Intercoms

The intercoms were specifically designed and packaged for use in the Sunshine mine. The units were configured from standard Wescom intercom modules in both 8-station (figure 4-21) and 17-station (figure 4-22) versions.

These intercoms are small party-line switching centers that connect to a PBX line circuit directly or via the carrier system. Operation of the 8- and 17-station intercoms is identical; however, the 17-station has extra station relays and must use a 2-digit code to represent the additional stations. Stations 1 through 8 on the 8-station intercom are called by dialing the digit corresponding to the station number. On the 17-station intercom, the stations are numbered 1, 3 through 8, 20, and 22 through 29. The call processing on both intercoms is sequential. Figure 4-23 shows a block diagram of the intercom stations.

When an intercom telephone is taken off hook, a current loop relay is energized, enabling the tone decoders. Intercom dial tone (1300 Hz) is heard since it is normally present on the audio bus. To call another station telephone on that intercom, the user presses the desired DTMF number key.

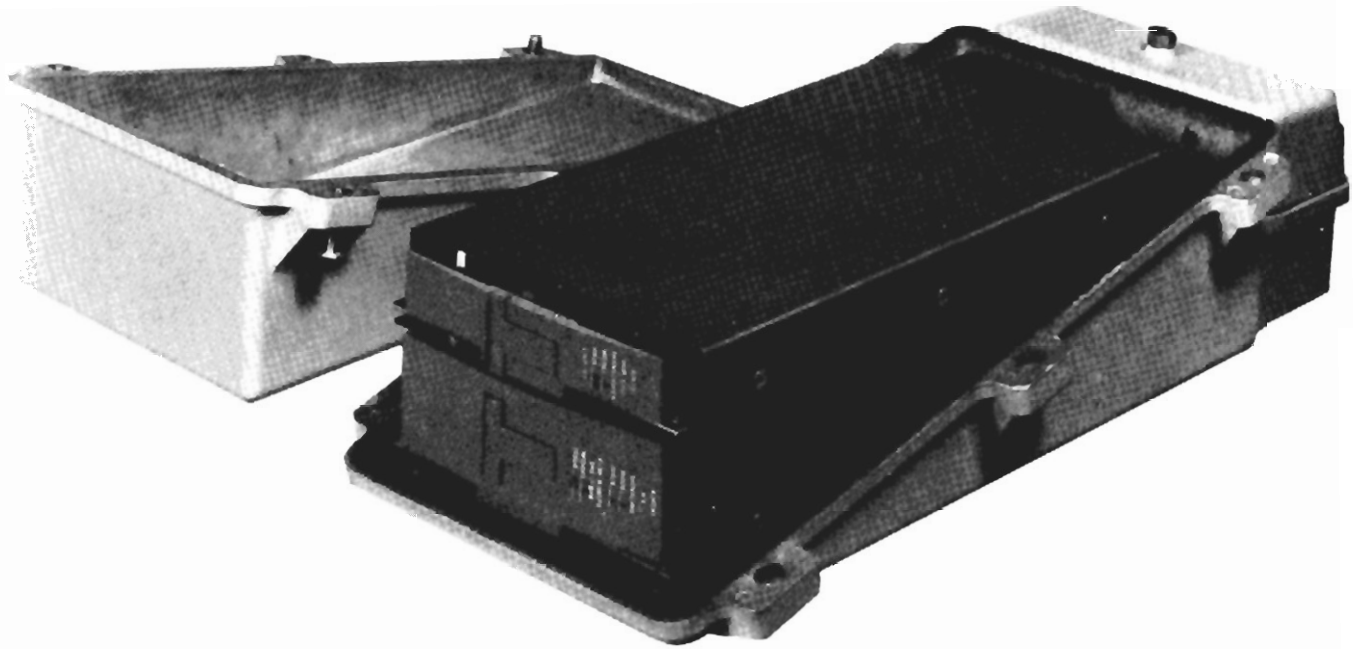

Figure 4-19. Single S6A Subscriber Terminal.

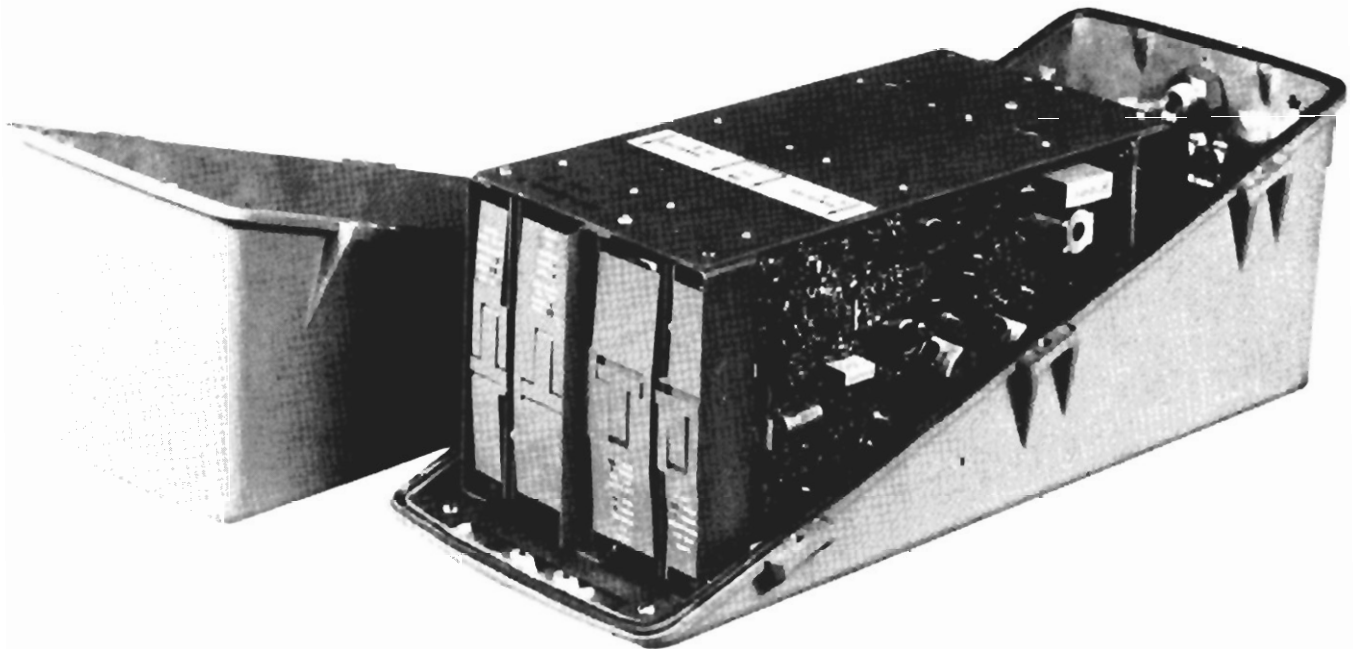

Figure 4-20. Dual S6A Subscriber Terminal.

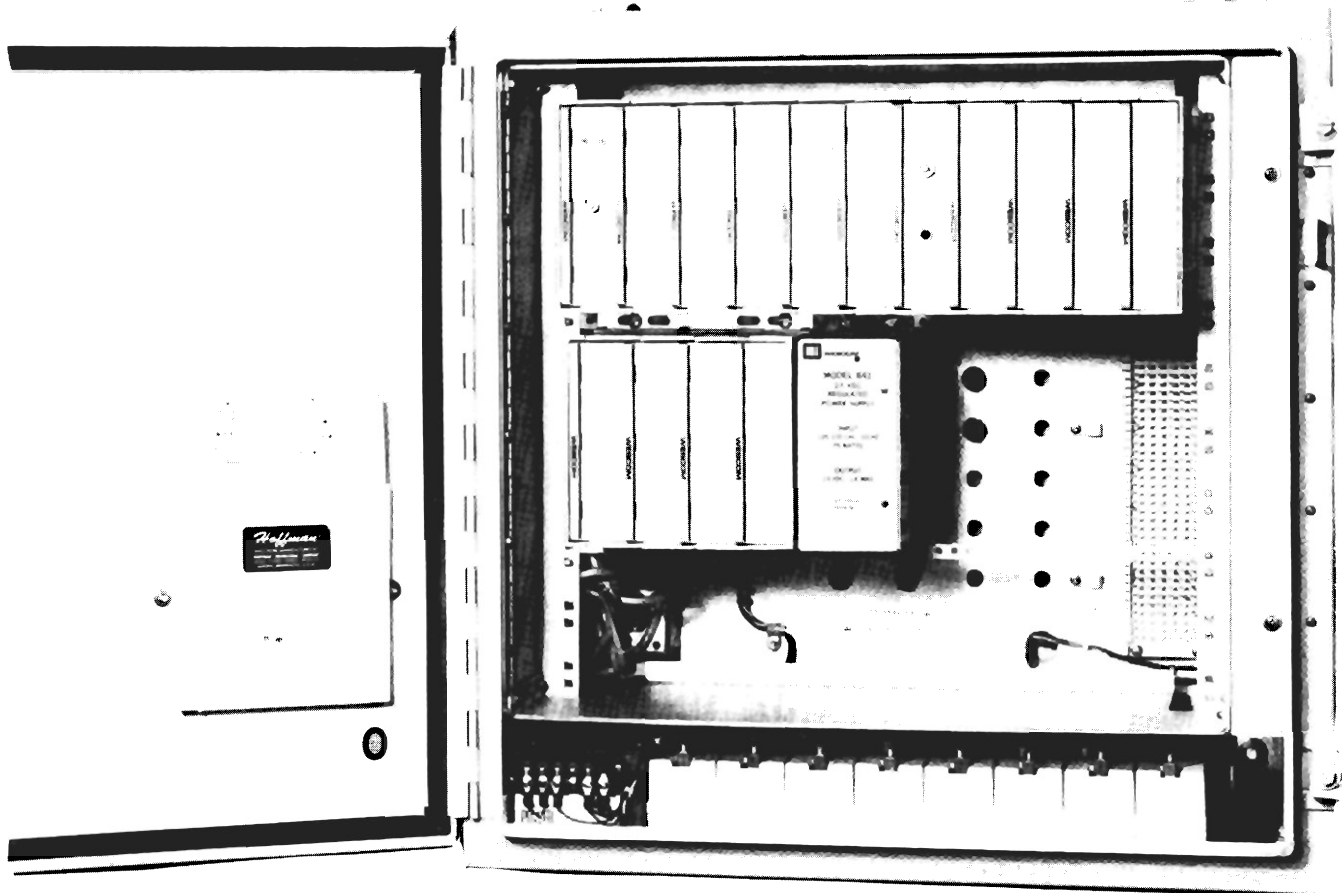

Figure 4-21. 8-Station Intercom.

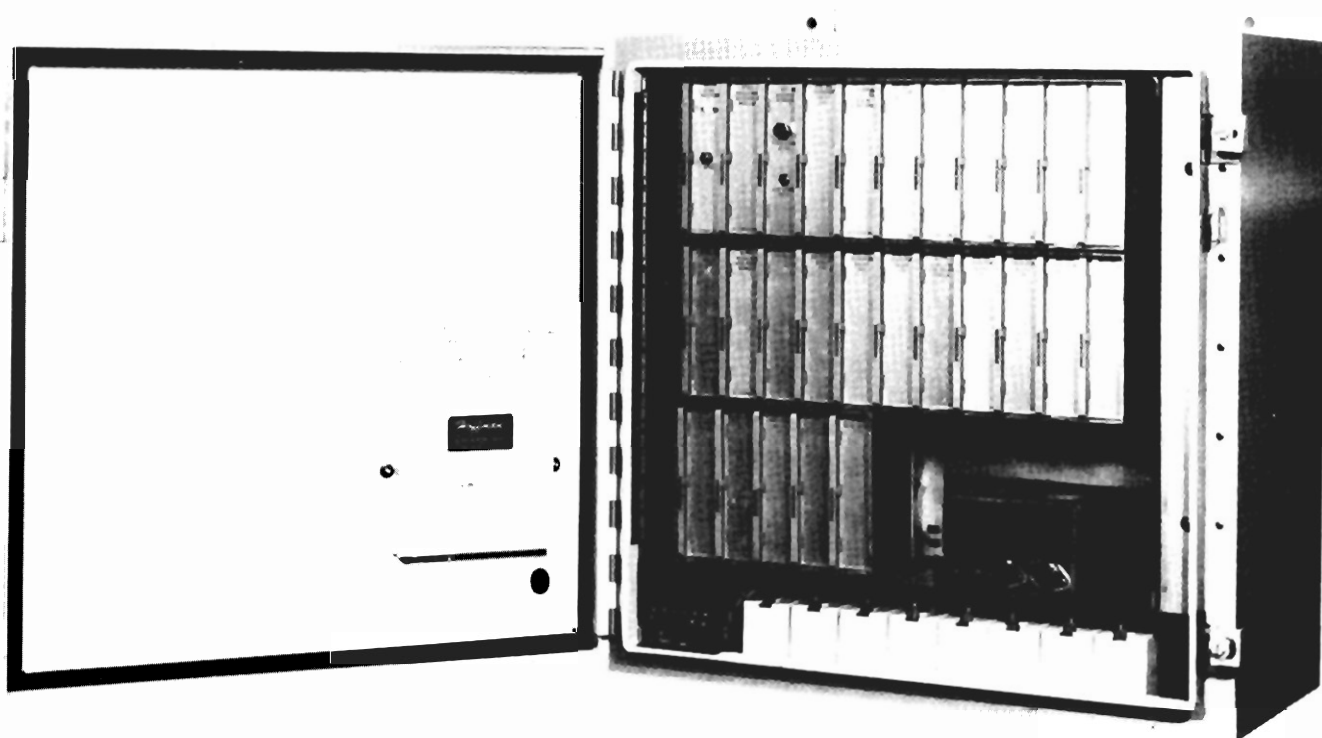
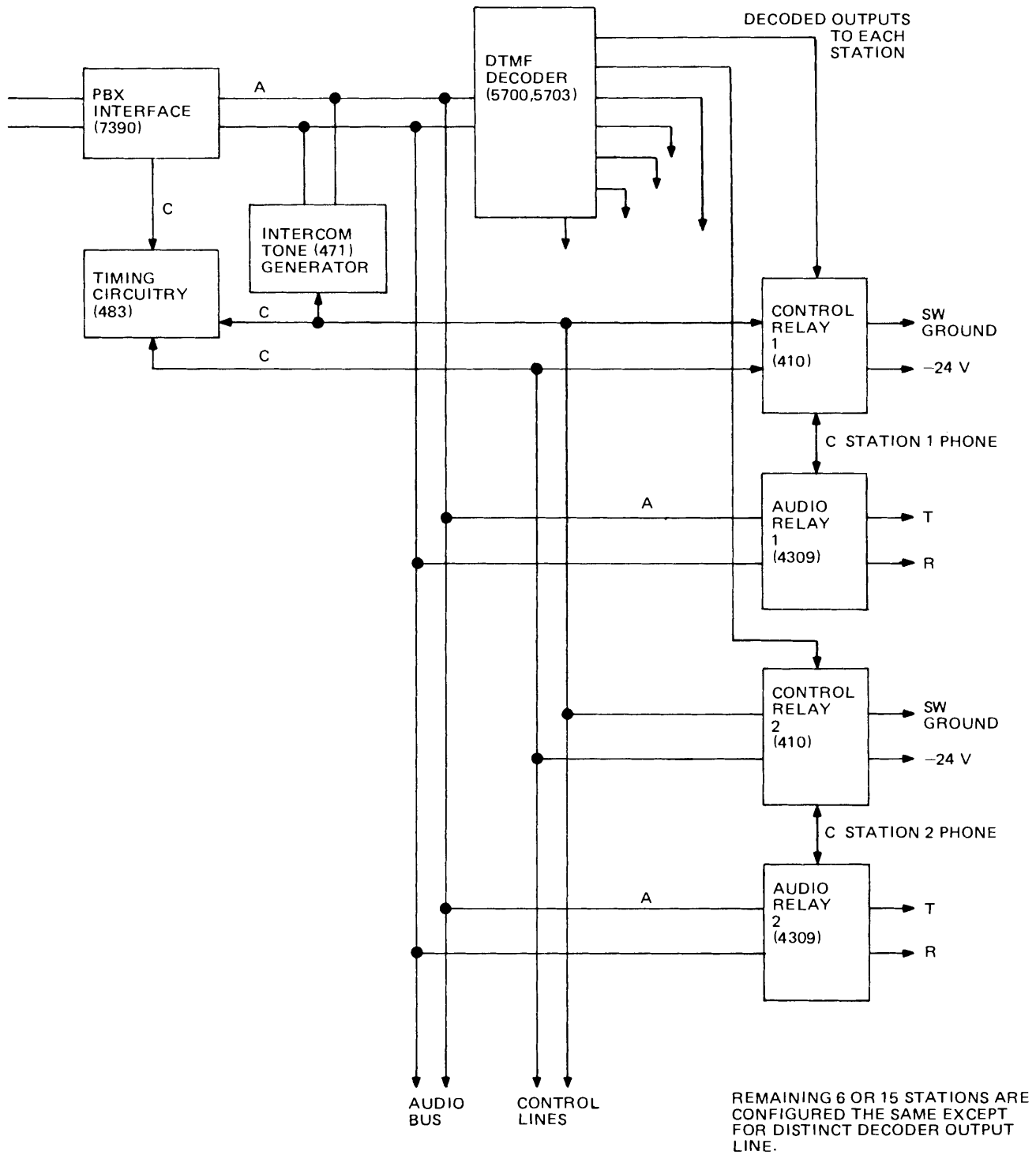

Figure 4-22. 17-Station Intercom.



TP5-6717-011

Figure 4-23. Intercom Station Block Diagram.

The tone modules decode this number and initiate the following:

- a. Dial tone is removed from the audio bus and ringback is applied to the calling telephone.
- b. A switched ground is applied to the called station which sounds its Klaxon.
- c. The tone decoders are squelched, allowing no further signal decoding.

The intercoms also feature an emergency all call. By dialing 0 after accessing an intercom, all telephones on that intercom ring. The ringers are disabled one by one as the telephones come off hook to answer the call. An emergency conversation can be conducted with the ringback tone in the background. The ringback is removed from the line when all telephones have answered.

The intercom shelf assembly was packaged in a Hoffman Engineering enclosure with self-contained rechargeable batteries. The units are normally powered from 115 v ac. A charger/power supply recharges the backup batteries and provides 24 v dc to the intercom circuitry. Five 115-v ac outlets are included in the box for powering test equipment or a heating element if needed.

The enclosures are designed for ease of installation and maintenance. Access is provided to the back of the intercom shelf by a swing-out gate (figure 4-24). The stations have individual fuses on each of the 24-volt Klaxon power lines. The power supplies and batteries are protected by fuses located on the back panel.

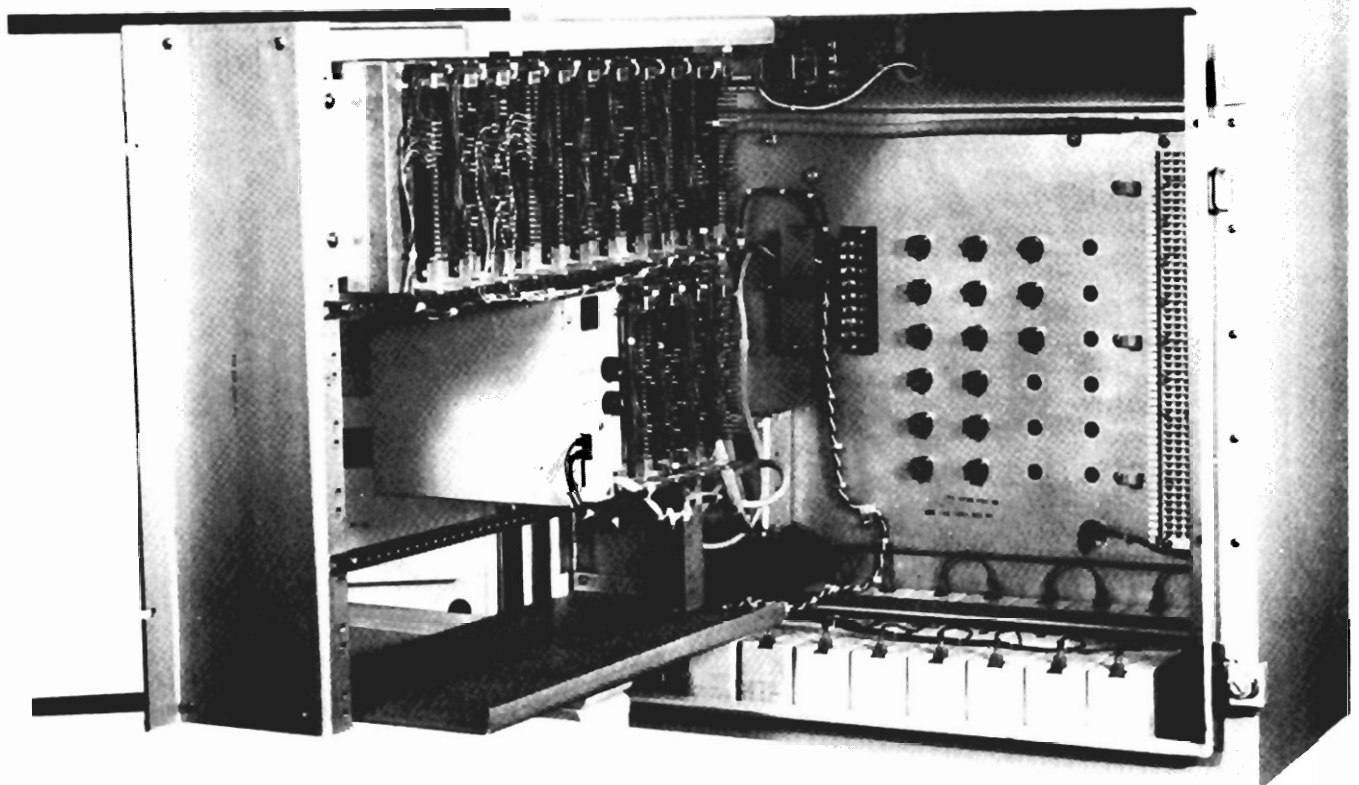

Figure 4-24. Intercom Swing-Out Gate.

The heat created by the power supply and intercom modules keeps the inside of the enclosures dry, even in the moist Sunshine mine atmosphere. The Wescom cards and wire-wrapped backplanes were not modified and an additional heater could be installed if needed in a particularly moist area. The outside of the enclosure is painted with an epoxy paint to withstand the abuse and corrosive conditions. Intercom specifications are listed in paragraph 6.0.

4.7 Telephones

The telephones are weatherized DTMF units manufactured by Allen-Tel (figure 4-25). Modifications to the telephones included a loud 24-volt Wheelock Klaxon, a push-to-test or signal button, and a terminal strip. A 20-Hz relay was installed on all telephones that were to be connected directly to the PBX (figure 4-26).

The intercom and PBX telephones are connected identically when installed. The PBX telephones may be installed on an intercom; however, intercom telephones cannot be signaled directly from the PBX due to the lack of a 20-Hz relay. The PBX telephones require four wires: audio tip and ring, 24 v, and ground. The intercom telephones require five wires: audio tip and ring, 24 v, switched ground, and ground. The ground wire, which is used for the local press to test capability or for installing a 24-volt heater, may be deleted if these capabilities are not required.

The telephones are mounted using a standard mounting bracket available from Allen-Tel. Straps for attaching the telephones to posts are also available. Specifications for the telephones are listed in paragraph 6.0.



Figure 4-25. Weatherized Telephone.

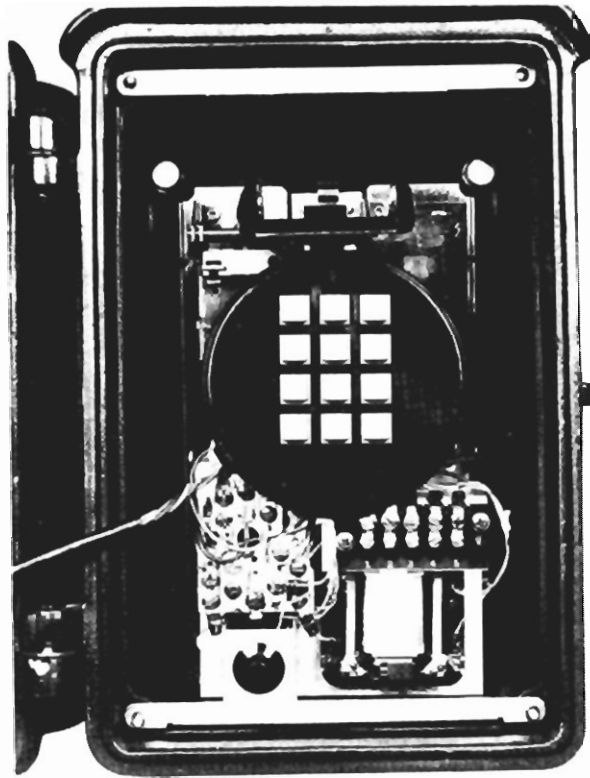

Figure 4-26. Weatherized Telephone (Internal).

4.8 Installation

All components were received and tested individually at the Collins Commercial Telecommunications Division labs in Cedar Rapids, Iowa. The intercom design required modification by Rockwell-Collins to meet the goals for desired system operation. A complete enclosure system for intercoms was designed by Rockwell-Collins to meet the system criteria for backup power, ease of maintenance and installation, and environmental protection. The PBX carrier system and telephones were standard, commercially available items, requiring only minor packaging and testing to ensure correct system performance. The unpacking effort was directed toward ease of installation and maintenance.

Individual subsystems were thoroughly tested. To verify system operation, the subsystems were assembled into a partial system which would be similar to the system to be installed in the mine. Lack of available space would not permit the entire system to be tested at one time, however all features of system operation were tested including the following:

- a. PBX switching capabilities, line-to-line
- b. PBX-to-intercom access and signaling
- c. Intercom-to-PBX access and signaling
- d. Carrier system operation (or transparency)
- e. Intercom all call
- f. PBX class restriction on applicable functions
- g. Attendant's console operation

The system components were thoroughly tested and burned-in for several months as the packaging efforts continued on the intercoms and central office assembly for the carrier system. The assemblies were documented and given a final check before the system was dismantled and shipped to Sunshine.

During system assembly and testing at Rockwell-Collins lab, installation drawings were made and placement of all major assemblies verified with Sunshine personnel. Telephone drop cable for installing local telephones and intercom station telephones was obtained by Rockwell-Collins. Sunshine engineers were consulted and the mine conditions carefully noted before selecting this cable. Six-pair, No. 22 AWG, shielded cable was selected for the installation. The cable contains a moisture-resistant grease and meets REA specifications for direct burial cable. The cable was shipped directly to Sunshine from the vendor. The uninterruptible power supply was also shipped directly to the mine.

After verifying that the cable and telephone system had arrived at Sunshine, a Rockwell-Collins team was sent to the mine to aid in unpacking, equipment placement, final hookup, and test. The miners were on strike, which allowed easier movement within the mine. Since the system had been tested prior to shipment and access to the mine was excellent, the basic system was installed in less than 2 weeks. Using predetermined plans, the intercom stations, PBX, telephones and carrier systems were installed.

The PBX and carrier system central office were installed first. Both were located in the air conditioned Rock Burst monitor room (figure 4-27). All PBX cables were brought out on a distribution frame of quick-connected blocks. Four local PBX telephones were wired directly to the PBX from the distribution frame (figure 4-28).



Figure 4-27. Rock Burst Monitor Room PBX Installation.



Figure 4-28. Underground Electric Shop Telephone Installation.

The carrier central office was connected to the distribution frame according to the system numbering plan. Cables were installed from the central office assembly to the mine wiring distribution box. One carrier line was connected by a twisted pair going to the Jewell shaft, the other carrier line was connected by a twisted pair to the No. 10 shaft. Telephones, intercoms, and subscriber terminals were positioned at the various shaft stations as planned (figure 4-29). The average distance between the intercom, subscriber terminal, and station telephone was often less than 50 feet (figure 4-30). Two intercoms and three carrier channels, housed in a multiple subscriber shelf, were located on the surface to provide communications and a channel for monitoring (figure 4-31).

There were no twisted wire pairs available on the ac signal cable in the Jewell shaft. Since the mine was on strike, a wire pair used for the sandfill operation was isolated and used for the carrier systems. When the carrier systems were turned on, the system in the Jewell shaft was operational. The system in the No. 10 shaft was not operational. The subscriber drop to the 4200 level carrier was approximately 200 feet. This distance was too long to be bridged directly across the carrier line without line treatment equipment. A splitter and line terminator were installed, making this drop into another carrier line. The No. 10 carrier system was then operational.

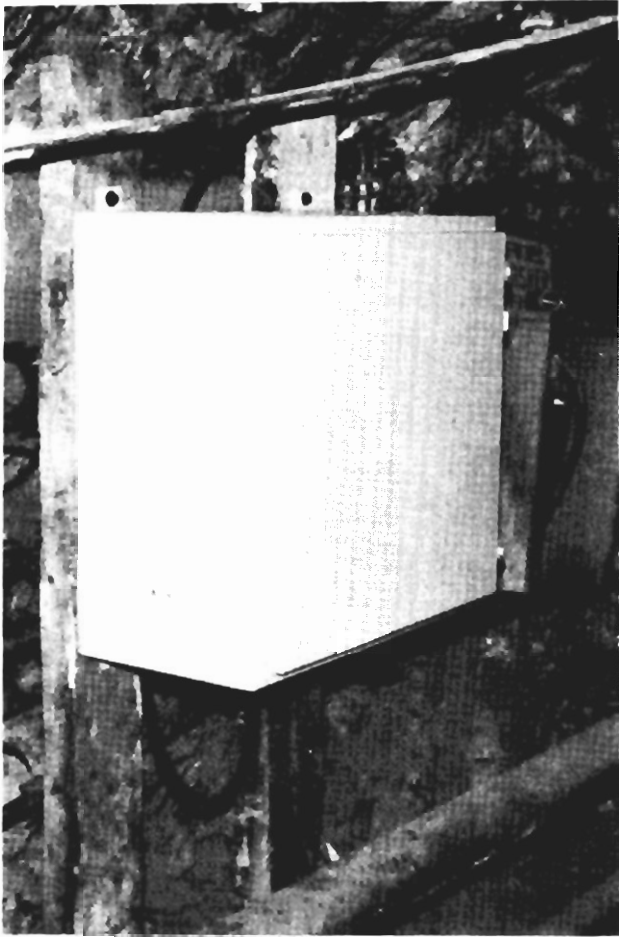

Figure 4-29. Shaft Station Subscriber Drop and Intercom Installation.

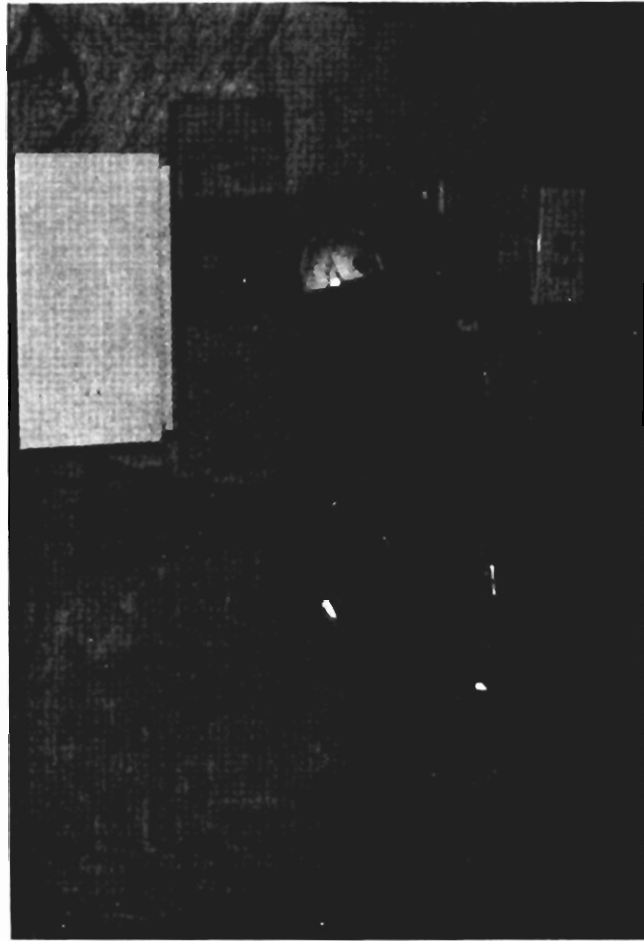

Figure 4-30. Telephone, Intercom, and Carrier Drop Installation.

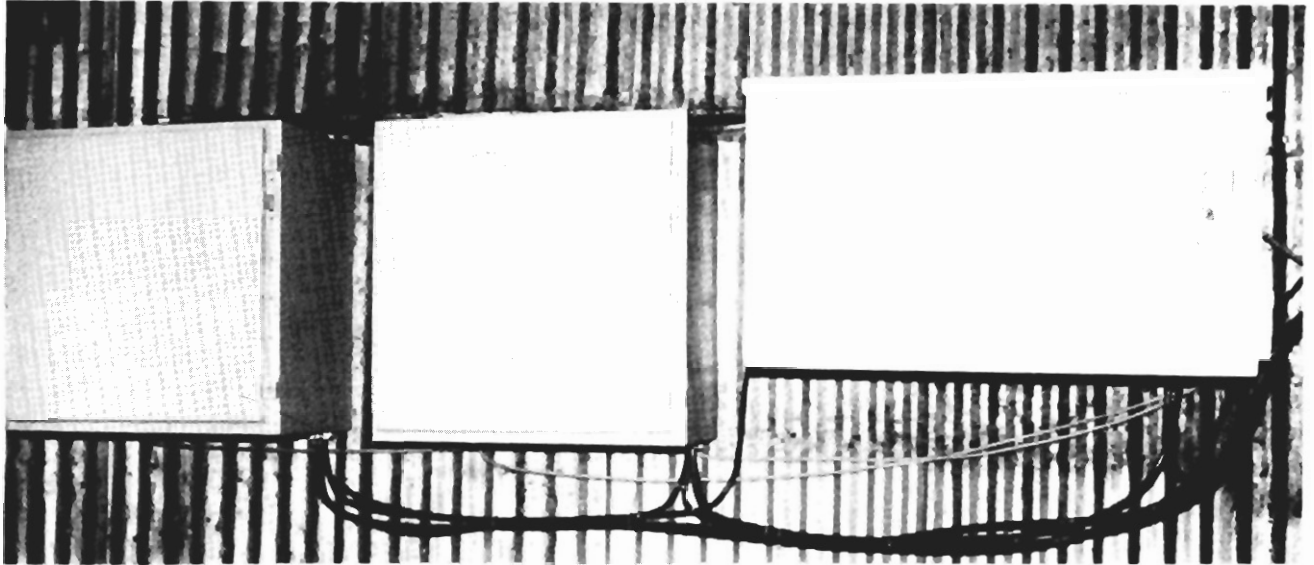

Figure 4-31. Surface Intercom Installation.

The UPS was installed in the mine by Sunshine personnel (figure 4-35). Final wiring connections to the PBX and carrier central office were made by Sunshine electricians with the supervision of Rockwell-Collins technicians. Additional intercom station telephones were installed on every major level of the No. 10 shaft below the 3700 level by Sunshine personnel. An additional station telephone was also installed on the 4800 level No. 12 shaft from the 3700 Jewell intercom. Intercom telephones are planned for the 1700 and 2700 levels of the Jewell shaft. These will be installed by Sunshine electricians.

The expansion capabilities of the system are quite extensive. Less than one-third of the 60 PBX line circuits are presently being used. The PBX also contains provisions for 12 trunks. One trunk could provide a separate wire path to the surface via the Silver Summit escapeway. Shaft wiring is not available to implement this function at present. An individual PBX line circuit could also be wired to the intercom on the 3100 No. 10 level. An intercom station telephone could then be used to provide a surface link to the Silver Summit. A spare channel is also available on each carrier system for expansion. The intercoms have capacity for approximately twice the telephones presently installed. Much of this additional capacity is not needed at present but will be used when the mine begins developing stopes near the No. 5 and No. 12 shafts.

Calls were made to test operation of the systems. The PBX, intercoms, and carrier system were functioning as desired except that intercom station-to-intercom station access was marginal. An intercom could be accessed, but the last digit used to signal the station was not detected. This problem would occur only when calling from one intercom station telephone, through the PBX and carrier system, to another intercom station telephone. The signal losses were greater than experienced with the short carrier system length used in laboratory tests. Analysis of the intercoms revealed that they were heavily loading the audio bus. The intercom current loop holding circuit (consisting of a 500-ohm resistor) was replaced with a 1000-ohm resistor, resulting in a better impedance match between subscriber terminal and intercom and less loading of the audio bus. System calling tests were conducted again with acceptable results.

The installation of the remaining intercom units and station telephones (figure 4-32) was completed. Surface telephones were installed in the engineering office, electric shop (figure 4-33), machine shop, warehouse, Jewell top station, shifters shack, both hoist rooms, and the safety office. All intercom station telephones were installed using six-pair cable. The carrier system was connected to mine electrical boxes and wired to twisted pair. All connections were made using standard electrical wire nuts in a manner that was consistent with Sunshine Mine practices. Figure 4-34 shows the connections required on the Jewell 3700 level. Wiring on the other intercom stations is basically the same.

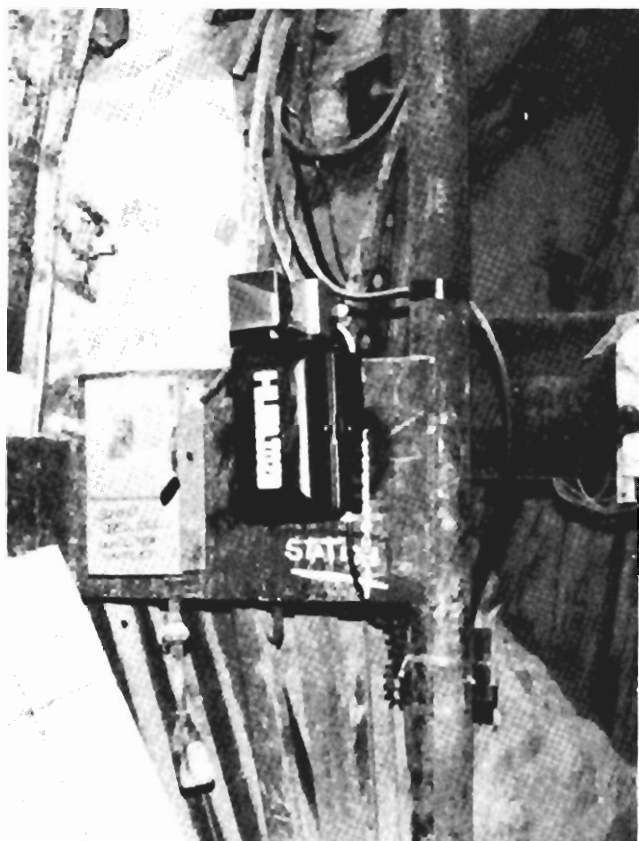

Figure 4-32. Station Telephone Installation.

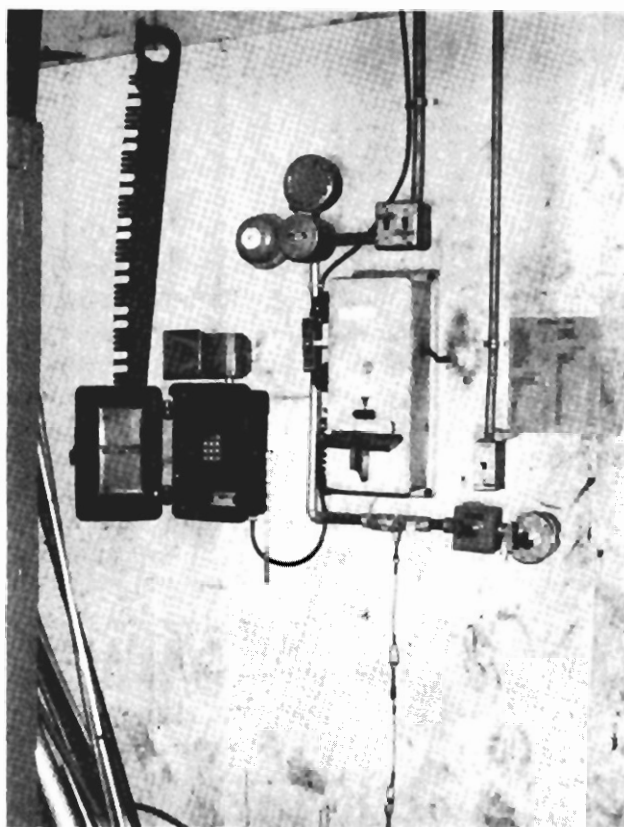
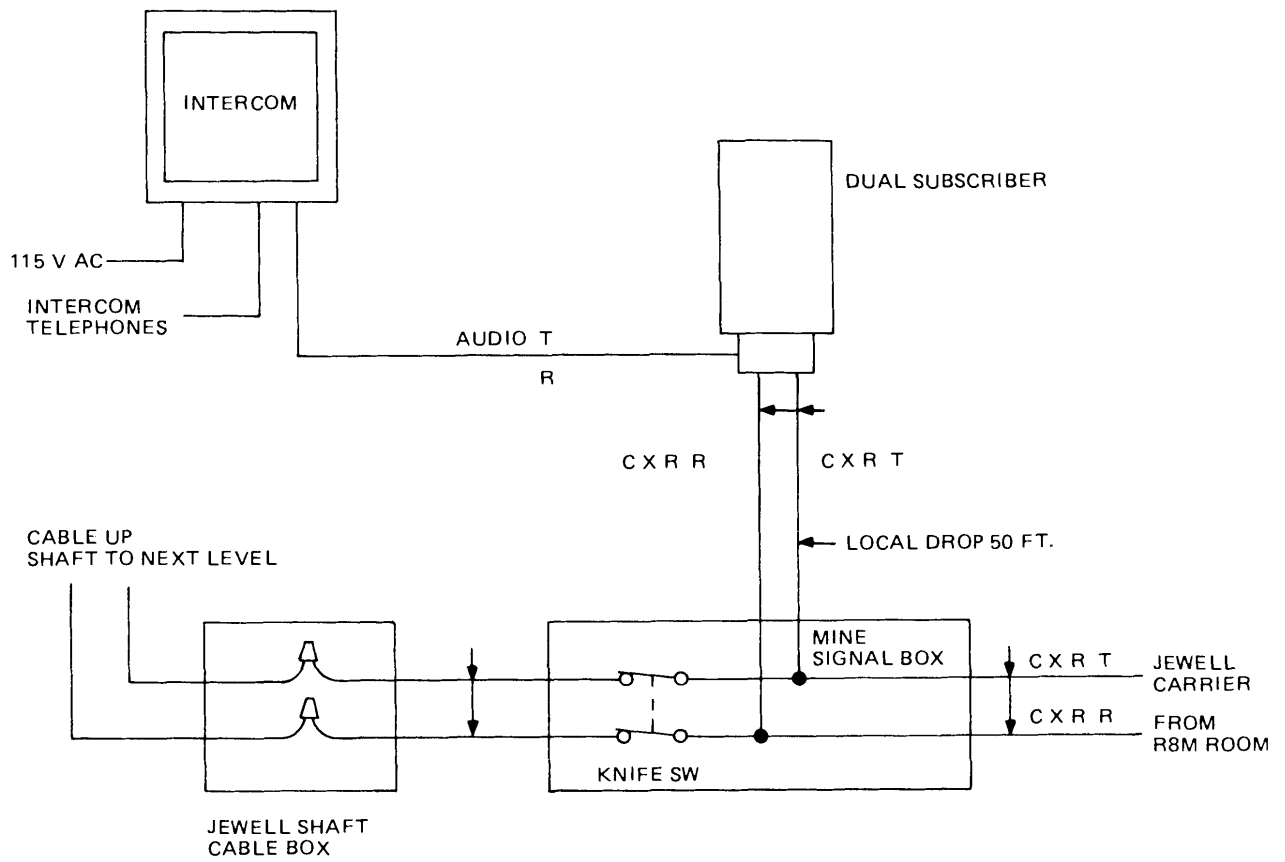

Figure 4-33. Surface Electric Shop Telephone Installation.



TP5-6719-011

Figure 4-34. System Installation Drawing.

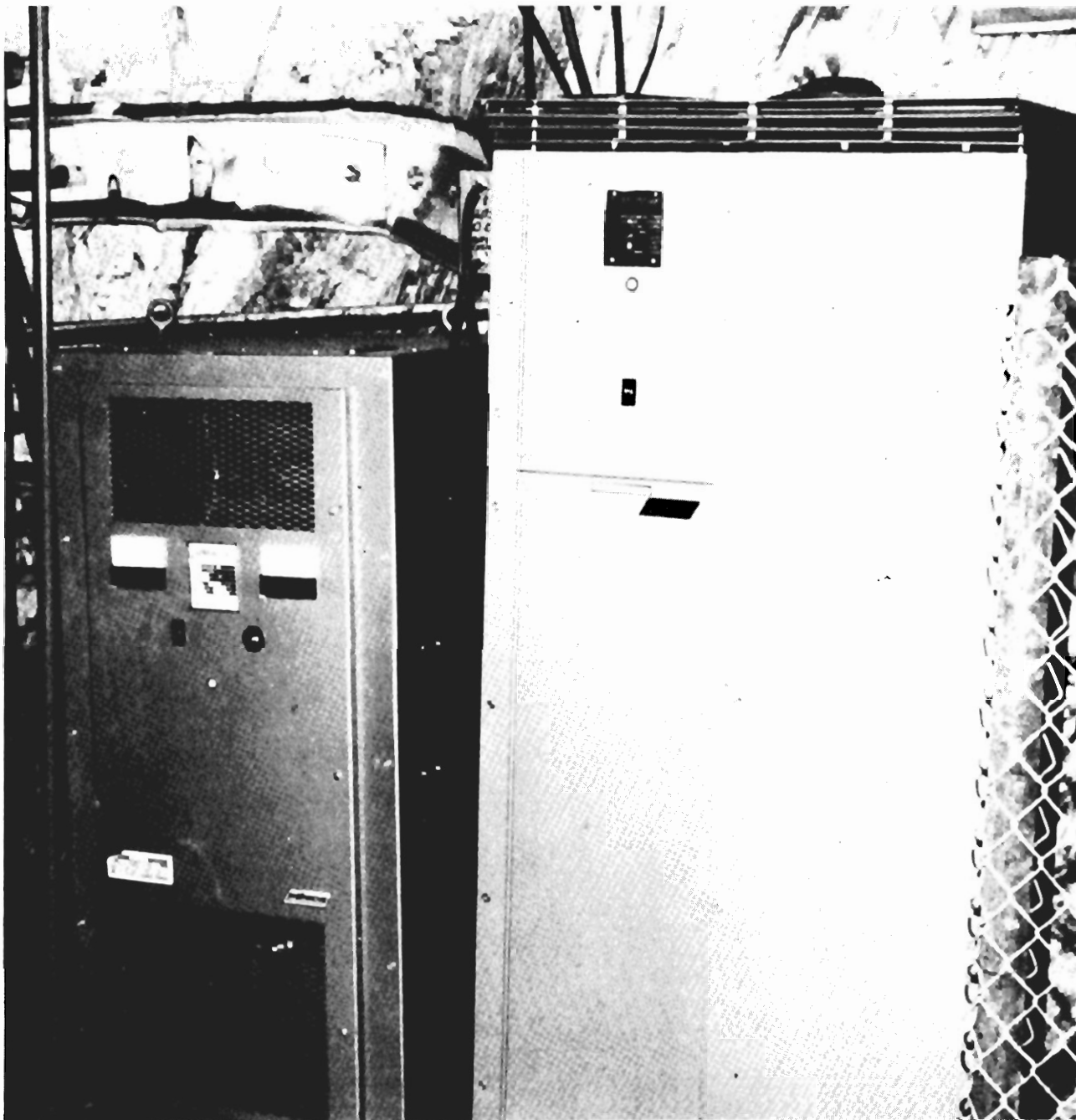

Figure 4-35. Uninterruptible Power Source Installation.

4.9 Follow-On Maintenance and Support

Sunshine maintenance personnel were supplied with manufacturer's equipment manuals on the carrier system and PBX. Schematics and wiring diagrams were provided with the intercoms and telephones. Supervisory personnel were also instructed in the operation of the system. The mine's strike ended in March 1977, about 2 weeks after the initial installation of the telephone system. Since electrical crews had not participated in the installation or received previous instructions due to the strike, they were provided on-site training by Rockwell-Collins. Supervisory personnel were then available to return to their duties.

Few problems were experienced with the system after the mine returned to production. The Jewell sandfill cable was needed for mining operations and the Jewell carrier system was taken off the twisted pair and connected to random wires that were available, resulting in a large amount of interferences from signaling bells and other induced transients. The telephone service was acceptable, but noise and false signaling caused random problems throughout the system.

An electrician with an electronics background was hired to maintain the telephone system. He received training in system operation and maintenance by Rockwell-Collins personnel while they were conducting measurements at the mine in December 1977. During this period, the Jewell carrier system was switched to a more acceptable twisted wire pair.

The 1-kilohm PBX loop resistor on the intercoms was replaced with a passive network that displayed approximately 600 ohms of resistance with respect to dc, but over 1,500 ohms of impedance at the DTMF tone frequencies. A 2-db improvement in audio levels resulted in greatly improved system operation. Sunshine has performed all maintenance on the system since the previous mentioned measurement trip with only occasional troubleshooting assistance from Rockwell-Collins.

Two major problems developed during the first year of system operation at Sunshine. One problem was failure of the loud Klaxon on telephones located in the very moist atmosphere of the No. 10 shaft stations below the 3700 level. The first failures occurred about 3 months after installation. The failed units were returned to Rockwell-Collins for analysis. The failures were attributed to extreme corrosion caused by condensation inside the enclosure (figure 4-36). The moisture entered via the conduit used to connect the horns to the telephones. The problem was corrected by sealing the connection with a corrosion inhibitor and installing a 24-volt, 1-1/2-watt heater inside the Klaxon. The heater maintains the temperature inside the Klaxon at approximately 5° above ambient. Since modification, no further failures have occurred.

The intercom and carrier subscriber terminals also experienced problems due to transients and bad ground references. The capacitors used to couple the intercom audio bus to the tone generator failed on two intercoms on the No. 10 shaft. The 35-volt capacitors were replaced with 50-volt capacitors on all No. 10 system intercoms below the 3700 level and the problem has not reappeared. Three carrier system subscriber drops failed on the No. 10 system below the 3700 level; two failed due to shorted or leaky transformers. The Anaconda literature recommends that the ground terminal on all subscriber drops be connected to a good earth ground, if possible; however, this was not possible on most of the Sunshine system.

The subscriber terminals were connected to the best ground available. Much of the electrical equipment on the No. 10 shaft was electrically "hot" on the enclosures. Sunshine is presently installing a power ground cable down the No. 10 shaft. This should alleviate future problems with hot telephone and intercom enclosures and subscriber terminal failures.

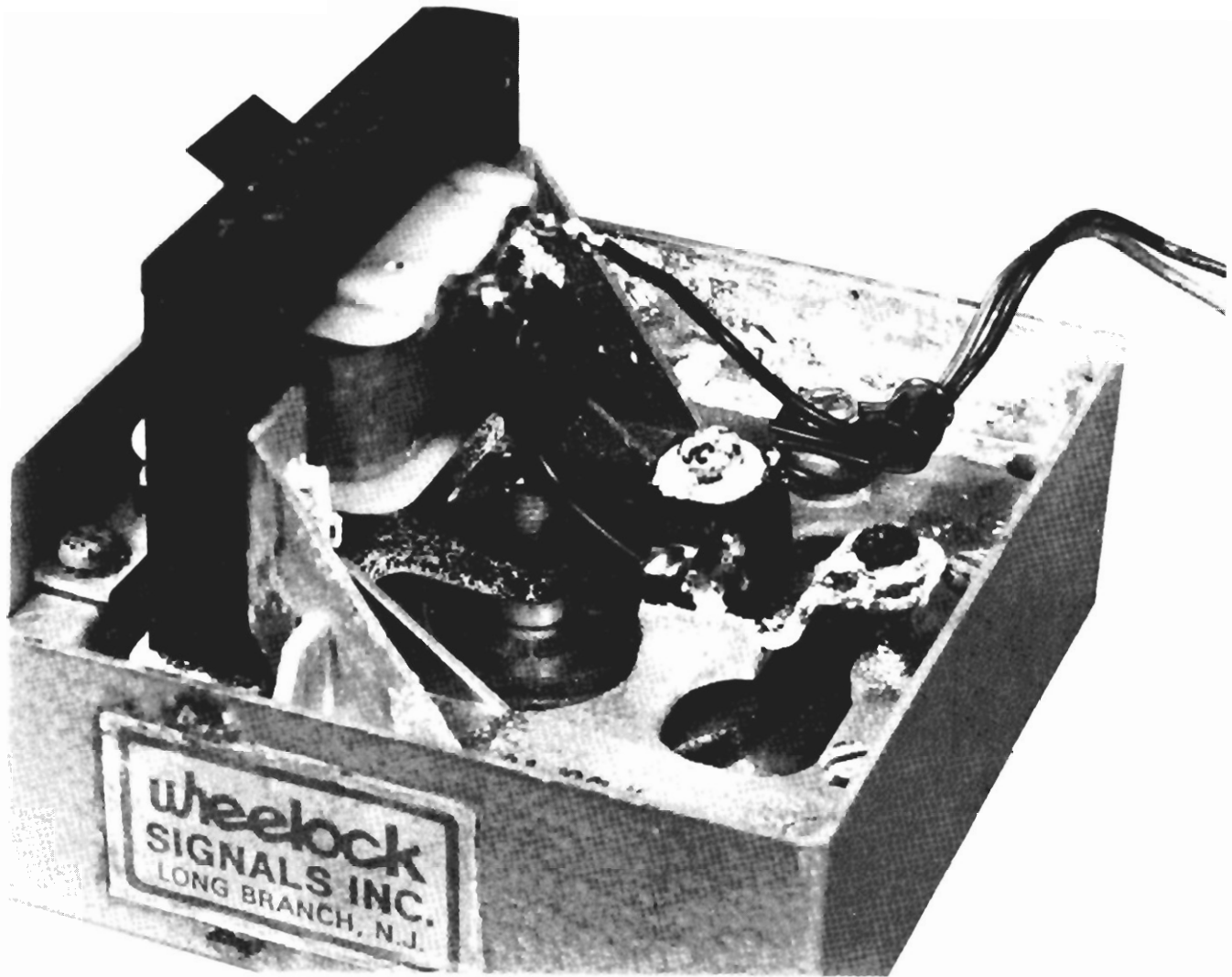

Figure 4-36. Corrosion of Underground Klaxon.

Other minor problems have been caused by the environmental conditions of the Sunshine mine. The intercoms below the 3700 level on the No. 10 shaft station have rusted around the door closures. Electronic circuitry inside subscriber terminals is still untarnished as a result of the heated atmosphere and corrosion inhibitors. The rust starts exactly where the epoxy paint stops at the door openings. Silicone grease was applied to eliminate further corrosion and was also applied to the wire nut connectors used in making connections on the system. This prevented corrosion of the wiring inside the connections. Corrosion problems are starting to appear inside the telephones on the DTMF contacts; however, no corrosion problems have occurred on intercoms to date. Heaters will be installed inside both equipment types as a preventive measure. Dust on the levels above 3700 has caused operating problems with several telephone hook switches, requiring periodic cleaning.

Overall reliability of the system has been good since its installation in February 1977. Signaling levels have improved with the intercom modifications and new wiring on the Jewell carrier system. The mine now maintains the system with minimal assistance from Rockwell-Collins or the USBM.

After modifying the intercom and installing new carrier system wiring, a series of measurements was made to record carrier and audio levels. The data from these tests are listed in paragraph 7.0.

4.10 Additional Monitoring and Control Capability

The Pulsecom Datalok 10 System was chosen to provide both digital and analog monitoring, relay control, multiple displays, and expansion capabilities without additional wiring. This system operates on a dedicated audio channel which was obtained by bridging together a channel from each carrier system in the central office (figure 4-37).

As configured for the Sunshine Mine, the system consists of three remote stations, a micro-master display, two master polling stations, and two teleprinter units. All control and monitoring will be centralized on the surface. The surface installation will consist of a master station, micro-master display and teleprinter. A backup master and optional teleprinter is located in the Rock Burst monitor room on the 3700 level. The optional teleprinter is remotely controlled by the surface micro-master. The 3700 master is normally operated in the slave mode and provides local display. The unit is capable of taking control of the entire system if the surface display should fail. The three remote stations are identical. Each station is capable of monitoring 2 analog signals and 24 relay contacts and controlling 5 latching and 10 momentary relays. The locations of the remotes are the No. 10 shaft 5200 level and Jewell shaft 3700 and 1900 levels. The remote locations are flexible and may be easily changed if desired. During a power failure, the system will operate for a period of 24 hours on the backup battery. The design objective was to employ off-the-shelf, readily available monitoring/control equipment and installation hardware. In addition, the system chosen was compatible with installation and maintenance capabilities of the mine maintenance personnel.

The master and remote stations were packaged, and the system was assembled and subjected to several months of burn-in and testing. The micro-master was the last item to be delivered, and it received a 2-week burn-in period with the system before shipment. This procedure allowed detection of bad components and possibly eliminated some frustrations in troubleshooting and testing the system underground.

4.11 System Operation

The Datalok 10 is a system for encoding parallel data into a time division multiplex serial stream and then recovering the data at the far end (or other locations) along the transmission circuit. The Datalok 10 uses a self-scanning Accuscan principle and a universal encoding/decoding scheme. The self-scanning principle permits unlimited expansion and system reconfiguration because no sequencer or programming is required. The coding/decoding scheme reduces all data to an 8-level (11 bit start/stop) ASC II code that is compatible with computers and teleprinters without code conversion. The Datalok 10 is a modular system with plug-in units providing control, encode, decode, and data transmission which can be rearranged for system expansion.

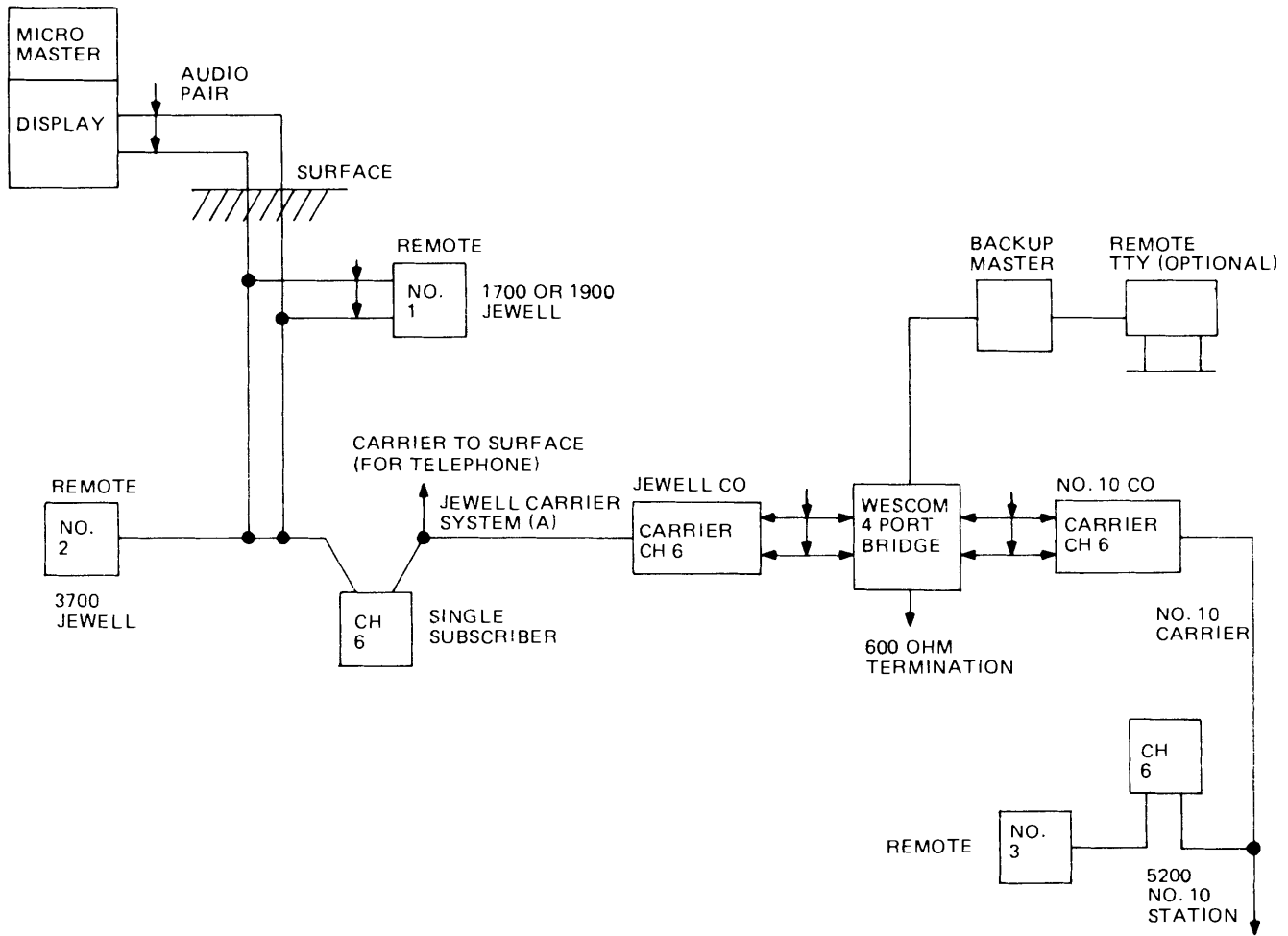

TP5-6721-011

Figure 4-37. Supervisory Monitoring and Control System Block Diagram.

The system is also flexible and may be operated point-to-point as a continuous reporting/control system, or as a polled system: one central unit serving many remotes. The Datalok 10 system installed in the Sunshine Mine is a polled system. The designated master station sequentially polls each remote station in the system via frequency shift keying (FSK) modem, operating at 100 baud. The master station transmits data on one voice-frequency channel (figure 4-38) and receives on a second voice-frequency channel. The remote stations receive on the first channel and transmit on the second. The micro-master transmits the teletype characters on a third channel to the remote teletype.

In normal operation, the master station polls each remote station in an orderly sequence. When a remote station decodes its address in a poll, the station keys its transmitter and sends back information on the status of all monitored points. The master unit then polls the next remote station and the process is repeated for each remote station. An alarm occurring at a remote station will be reported in less than 10 seconds to the master station. The master station processes data from only one remote station at a time. The 10-second reporting time is determined by the system baud rate and the number of remote stations in the system. The system operator may interrupt the polling cycle at any time to interrogate a single remote station.

Five latching and 10 momentary relays may be controlled at each remote station by the master station by putting the polling master in the manual interrogate mode, addressing the desired relay, and pressing the proper control button. This process, although fairly simple

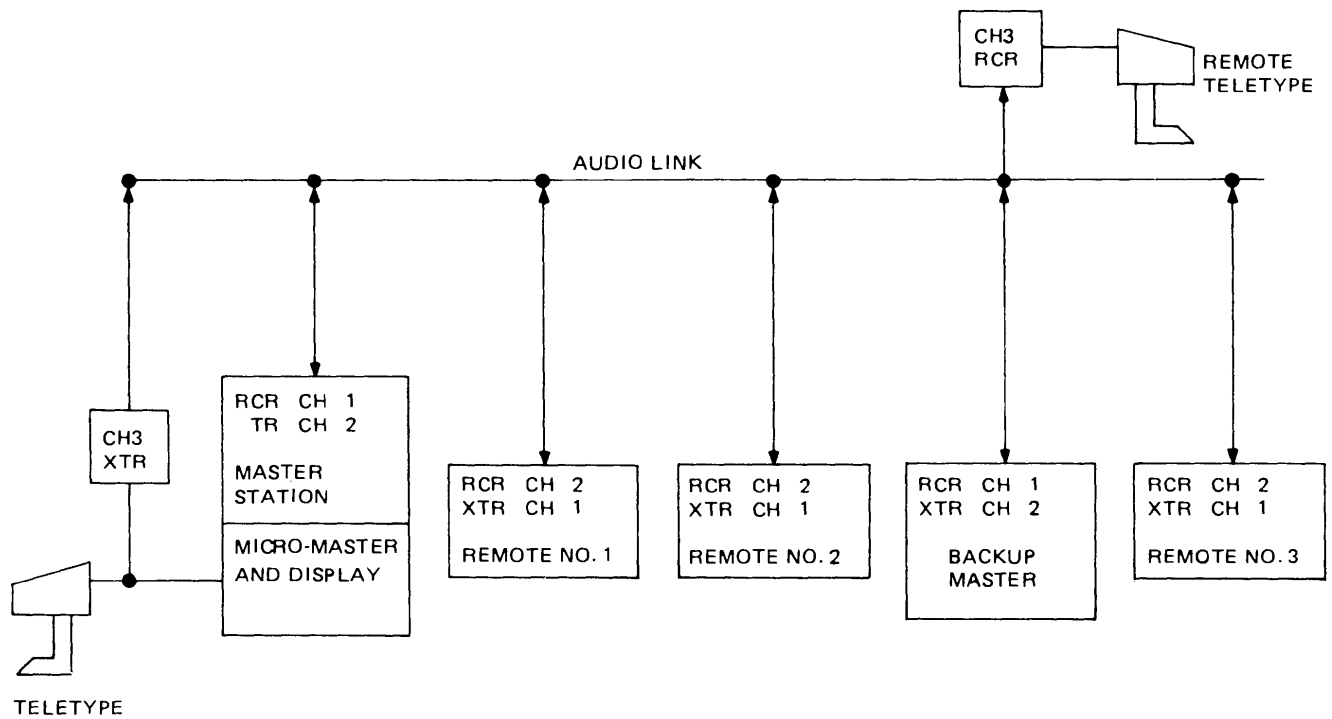

TP5-6716-011

Figure 4-38. Audio Signal Diagram for Monitor and Control System.

for a trained operator, requires a sequence which will probably prevent control by an unauthorized person. Control capability of the Datalok 10 system can be greatly expanded by adding printed circuit cards to the master and remote stations.

4.12 Hardware Description

The Datalok 10 system, procured and installed at Sunshine, consists of master stations, remote stations, and a micro-master display. An operational description at the Sunshine Mine system follows. A cost estimation is listed in paragraph 8.0.

4.13 Master Stations

The master station located in the Rock Burst monitoring room is housed in an epoxy painted enclosure (figure 4-39). The master station and the micro-master display is mounted in a 19-inch rack cabinet (figure 4-40).

The bottom shelf of each master station display contains a power module and three remote station cards. One remote station card is required for each remote station in the system. Each remote station card has four light emitting diode (LED) indicators and a 3-position switch. The STATION LED lights to show the station presently being polled. The alarm and change of status (ALARM/COS) LED flashes to show that an alarm or status change has occurred on the corresponding remote station. The major alarm indicator light (MAJ) may also light if the alarm has been programmed as a major alarm. If the remote station does not answer when polled, the no answer (NO ANS) indicator will light.

A 3-position switch is used to select the type of polling cycle for the master station. In the NORMAL (middle) position, the master station will stop the polling sequence when an alarm is detected at a given station. The master station will continue to poll only the alarmed station until the operator acknowledges the alarm by placing the switch in the MANUAL INTR position. The ALM/COS indicator will stop flashing and light steady, indicating a fault still exists but has been acknowledged. By placing the switch in the DISABLE position, the master station continues the normal polling cycle when an alarm is detected. (Polling does not stop as when the switch was in the NORMAL position.) The ALM/COS indicator will flash. The system operator again acknowledges the alarm by placing the polling switch in the MANUAL INTR position. The operator may, at any time, continuously poll only one remote station by holding the switch in the MANUAL INTR position.

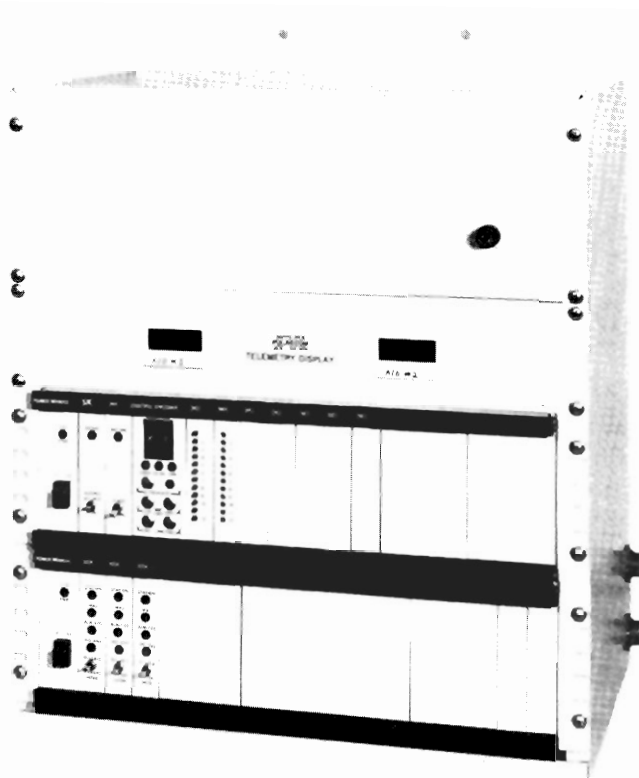

Figure 4-39. Rock Burst Monitor Room Master Station Assembly.

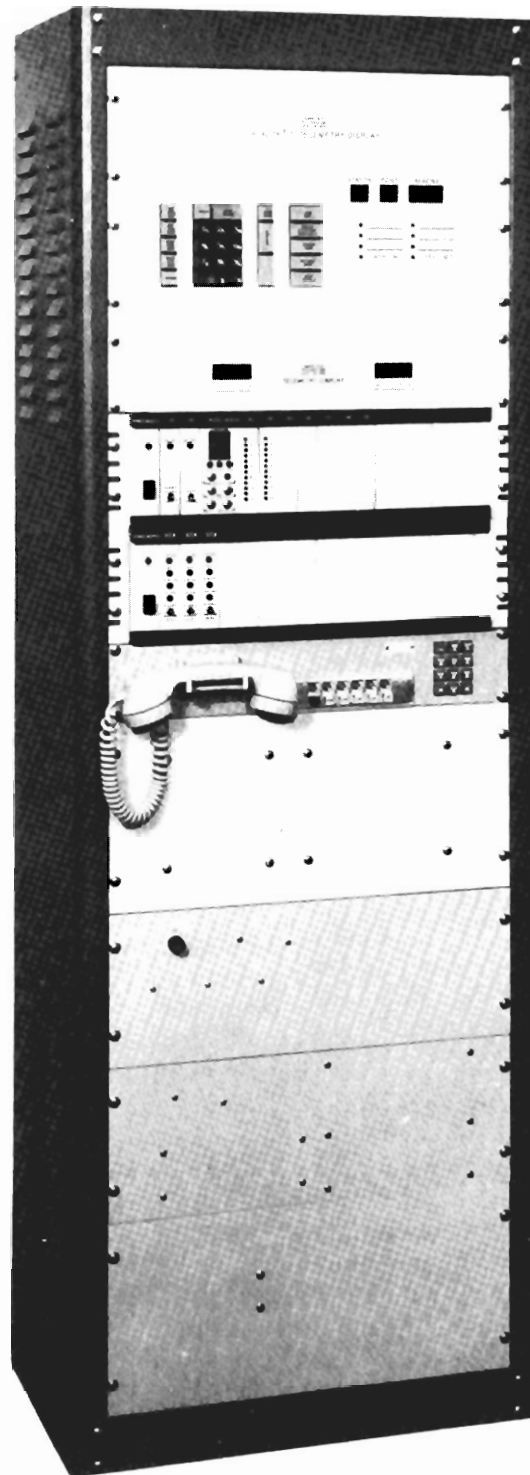

Figure 4-40. Surface Master and Micro-Master Rack Cabinet.

The upper shelf of each master station contains a power module, shift register, interface, control encoder, two alarm decoders, five 12-point decoders, and the FSK receivers and transmitters. The shift register and interface card provide data shifting and timing signals to the other modules. A toggle switch on the interface card allows the operator to place the master station in a slave mode. In the slave mode of operation, the master station decodes data and displays all alarms and telemetry values, but it does not poll the system. In the event of a failure on the primary master station, the switch can be set to the normal position and the backup master station will then poll the system. The control encoder implements control from the master station and can both control and obtain the status of up to 99 latching or momentary control relays.

The two alarm decoders are used to decode the alarm status of the remote alarm points. Each alarm decoder decodes 12 alarms and displays their status on one of the 12 LED indicators on the front panel. This display is used for each remote station, and the lights on the station card show which remote station's data the indicators are displaying at any given time. The remaining decoders are used to decode telemetry characters from the two analog-to-digital converters in the remote station. The values of these analog signals are displayed by the telemetry panel mounted above the master station. Each display gives a 3-1/2-digit readout which directly corresponds to the input value of the analog voltage. Example: Input voltage on remote is 0 to 19 volts; telemetry displays a 0000-1900. The largest value that can be displayed is 1999 since the most significant digit can only be 0 or 1 (1/2 digit).

The master station can establish a communication and data link with the remote stations using only four cards: the power module, shift register, interface card, and station card. The remaining cards in the master station are added to configure the master station for a given system. The number of stations which can be polled is determined by the number of station cards. An additional 12 points of alarm monitoring could be added by installing an additional alarm decoder card. The basic cards need not be replaced or altered to expand the capability due to the self-scanning operation of the station.

4.14 Remote Stations

The remote stations consist of one shelf of Datalok 10 cards (figure 4-41), rechargeable batteries, panel telephone, terminal field, and provisions for installation of a 115-v ac heater. The batteries provide in excess of 24 hours operating power during power outages. The panel telephone is connected to the telephone system intercom units. The terminal field is a rugged array of terminal blocks for in-mine installation of monitor and control inputs. The terminals are labeled.

The Datalok 10 equipment shelf of each remote station includes a power module, shift register, interface card, one 18-point encoder, two 12-point encoders, latched control and momentary control, and two a/d cards. The FSK tone equipment is also mounted on this shelf. The functions of the cards are much the same as, or complementary to, the associated cards in the master station. The shift register and interface cards provide data shifting and timing signals to the other cards. The 18-point encoder generates specific identification characters for data routing. Each 12-point encoder encodes the status of up to 12 normally open or normally closed relay contacts. The latched control card can control 5 latching relays, and the momentary control card controls 10 momentary relays. Each a/d card converts the analog input to digital output. Inputs ranges are 0 to 2 and 0 to 20 volts or 0 to 2 and 0 to 20 ma.

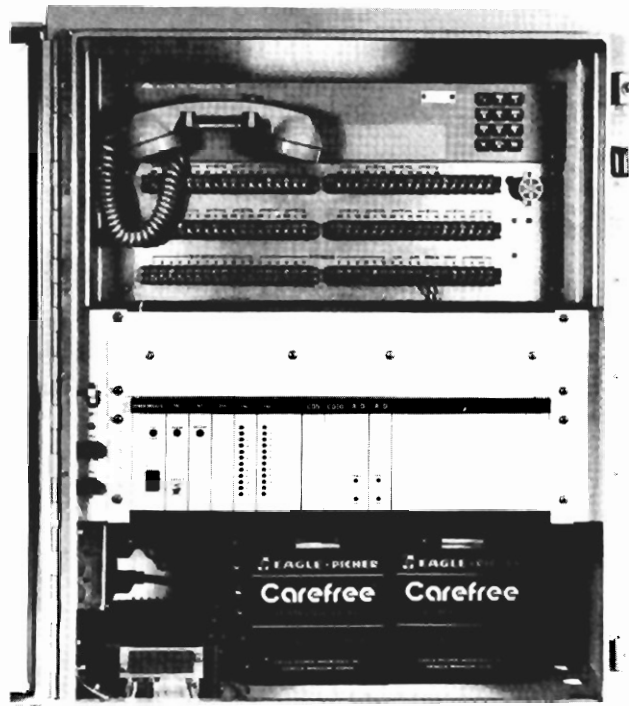

Figure 4-41. Remote Station Assembly.

The remote stations establish to a communication link with the master station using only three cards: the power module, shift register, and interface card. The remaining cards are added to configure the remote stations for a given system. Additional analog capability is obtained by adding a/d cards. A remote station could be configured as all analog or all alarm points. The basic cards need not be replaced or altered to expand remote stations capability due to the self-scanning operation of the system.

4.15 Micro-Master Display

For the alarm indications to be useful, an operator must cross-reference the alarm output to a notebook containing information as to station number and wiring information to that particular alarm point number. Also, the analog values must be scaled with an appropriate scaling factor for each remote station and the a/d point number to obtain actual values of temperature, percent CO, or voltage that the device is measuring. Computer programming (software) is used for cross-referencing and scaling.

The micro-master display consists of a 19-inch rack-mounted microprocessor and telemetry display. The unit is connected to the Datalok 10 system via cabling to the data bus of the master station. The micro-master displays decoded information from the bus in the same manner as the master station. When an alarm or change of status is detected, an audible alarm is sounded and a standard teleprinter printout of the alarm is provided. For example, suppose that the first fan on the 1900 level loses power (an alarm condition) at 9:05 am on March 16, 1978. The following printout would occur:

```
01 1900 JEWELL  
MAR 16 09:05  
21 3100 FAN # 1 ALARM OCCUR
```

Upon returning the fan to service at 2:15 pm this printout is given:

```
01 1900 JEWELL  
MAR 16 14:15  
21 3100 FAN # 1 ALARM CLEAR
```

The first printed line gives the remote number and its location, in this case, remote 01, located on the 1900 station of the Jewell shaft. The second line prints the month, day, and time (24-hour clock). The final line prints the alarm point number, 21, the device monitored, (3100 Fan No. 1) and whether the alarm occurred or was cleared. Printout for all alarm points on the remote stations are in the same form as this example.

For another example, suppose the temperature monitored on the 5200 level changes. The sensor normally reads 25 °C and 30 °C. If the temperature deviates from this range, a printout and alarm are received. If temperature increases above 30 °C the following printout occurs:

```
03 5200 #10 Shaft  
MAR 16 18:15  
1 30.15 DEGS 30.00 H OCCUR
```

When the temperature decreases below 30 °C, a similar printout will show a CLEAR status and the temperature. The printout for a low temperature level is identical except the letter L for low is substituted for the H and 23.00, the low limit, is shown.

Four scales have been programmed into the Sunshine micro-master display. These scales are used to adjust telemetry values into the appropriate percent CO units, degrees Celsius, ac current, and ac voltage. As many as 16 scaling factors may be programmed into the micro-master display.

In addition to the printed copy, the micro-master telemetry panel provides a visual display of all the analog values. This visual display shows the remote station number, analog point number, and analog value. An LED indicator lights to indicate the units the display is reading. A key pad is used to enter pertinent data into the microprocessor, such as resetting the month, day, and time; setting analog high and low alarm points; and requesting a status printout. The operator can manually program the unit to display values of selected analog points or out-of-limit points. Normally, however, the telemetry panel automatically sequences through all analog points.

Automatic status printouts are available up to 24 times per day. The Sunshine micro-master display is programmed for three automatic printouts, one before each shift change at the mine. As the system grows or changes, the micro-master display can be reprogrammed to provide additional printout and telemetry displays.

The Datalok 10 monitoring equipment was not received in time to be installed in the Sunshine Mine under Engineering and Administrative Services contract S0133035. The installation and follow-on support and performance of this equipment will be reported under a separate contract.

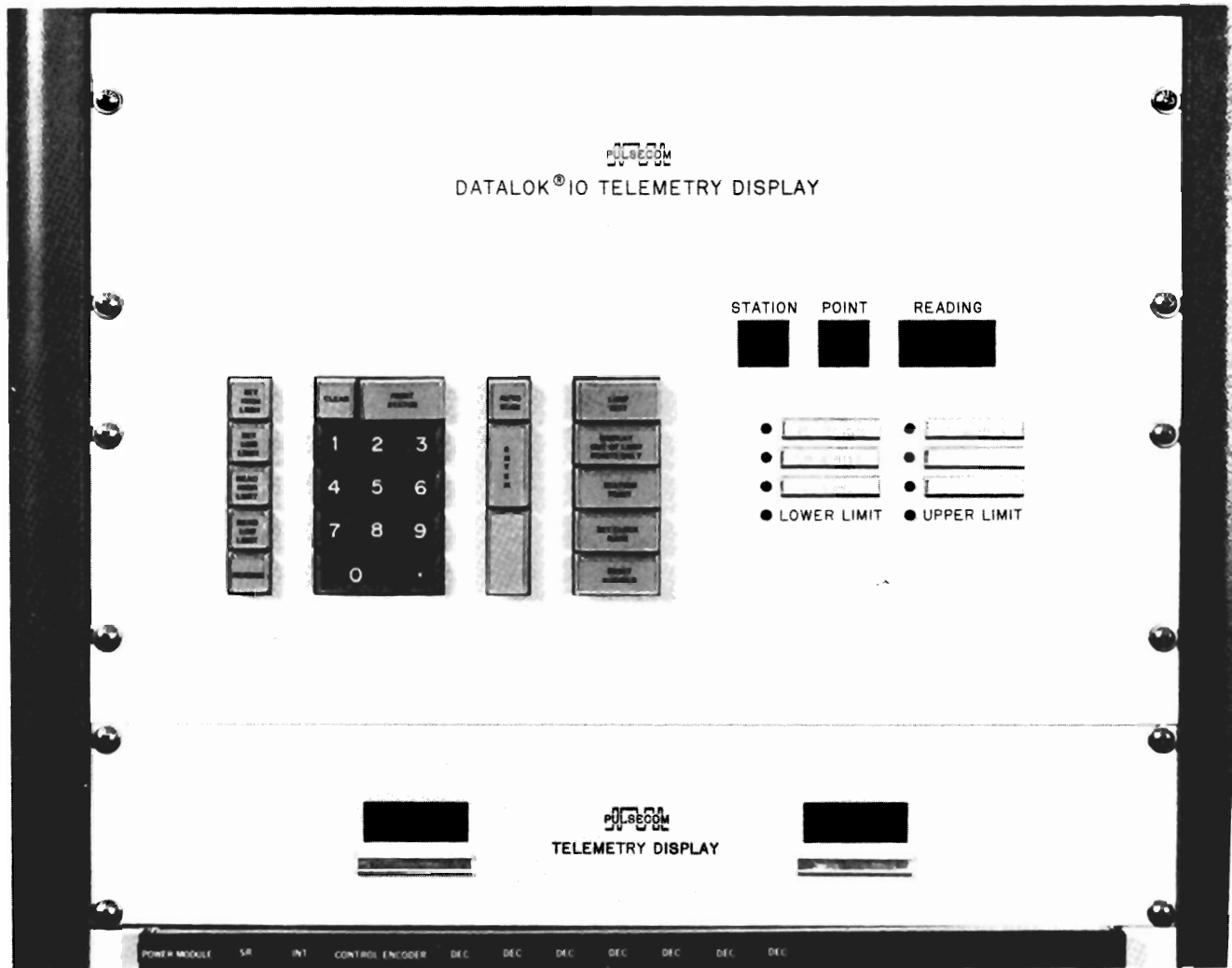

Figure 4-42. Micro-Master Telemetry Panel.

5.0 CONCLUSIONS/RECOMMENDATIONS

5.1 Conclusions

A carrier communication system utilizing a single wire pair to provide up to 14 voice channels is installed and operating in the Sunshine Mine Complex near Kellogg, Idaho. The system satisfies the objectives of providing more than one simultaneous conversation, selective signaling, and emergency backup communications. The installation of a special cable was not required for this system, as only one "voice grade" wire pair was required. Worker and management acceptance of the system has been excellent. The system has been and is being expanded by Sunshine personnel to keep pace with mine development. The hoist communication systems have provided a voice link and in-cage belling signals between hoist men and cagers for a safer and more efficient hoisting operation. A monitor and control system has also been selected and packaged for implementation at the Sunshine Mine. The installation and follow-on support of this system will be performed under a separate contract. At the time of this writing, the monitor and control system had been shipped to the Sunshine Mine and mine personnel were preparing for system installation.

Since the initial site survey in May 1975 through acceptance of the system in January 1978, there has been strong cooperation between the USBM/Rockwell-Collins team and the mine. Were it not for the support of the improvement goals by the Sunshine Mine, the program would not have been possible. All phases of the program produced favorable results. The Engineering and Administrative Service Program has contributed in significant improvements in hoist communication and carrier communications systems. Through various Bureau of Mines sponsored technology transfer seminars, the information gathered at the Sunshine mine has been presented to other mine owners and operators in an effort to promote the use of this technology. The hoist communication systems, intended to supplement the belling system, have improved communications between the hoist men and cagers. The safety problems associated with reaching out of a moving cage to give emergency stop signals have been solved by adding the in-cage belling option. The remote handset has been successful in coordinating communications between maintenance personnel and the hoistman during shaft inspection. Acceptance of both the Jewell and No. 10 shaft hoist radio systems was good. The Jewell hoist radio system has provided dependable service for over 2 years with minimal routine maintenance. Modifications to the original transceivers and the cage enclosures have greatly increased the reliability of the transceiver in the No. 10 cage.

As of this writing, sufficient time has not passed to ascertain whether the final modifications have resulted in a dependable, low-maintenance, hoist radio system in the corrosive atmosphere of the No. 10 shaft; however, there is no doubt that the No. 10 system is accepted and used by the miners.

The carrier communication system has added many communication channels within the Sunshine Mine without installing additional wiring. The system is utilized extensively by maintenance personnel and mine supervisors. The opinions of the personnel using the system on a day-to-day basis has been encouraging. The ability of mine management to contact personnel more rapidly is a valuable benefit. While it is difficult to measure the improved productivity or safety, there is little doubt that these improvements do exist. Mine personnel do not tolerate lengthy shutdowns during system modifications, a meaningful measurement that the carrier communications system is used for daily operation.

The voice channels on the system are quite clear, regardless of distance between the telephones. The background noise that occurs on the system is an intermittent one caused by

the ac signal bells in the Jewell shaft. The noise occurs only briefly and has not been a problem. There is no static or hum on the voice channels and no degradation has occurred due to seasonal effects. The noise-suppression circuitry of the carrier system is performing well.

System reliability since installation has been good. The PBX has performed well, with no down time experienced, even though several register cards required replacement. The PBX processes calls adequately using only one of its two registers. The telephones and carrier system on the Jewell shaft have not failed since installation.

Nearly all carrier system, telephone, and intercom failures have occurred on equipment after modification improvements were made. The intercom and Klaxons have not failed. The new grounding cable on the No. 10 power system has not been installed long enough to determine if it will prevent failures of the carrier system subscriber drops; however, the system down time resulting from these failures has been small. Overall system reliability described by mine personnel is quite good.

Mine personnel are performing all required system maintenance. Several factors have greatly helped to achieve these results. The troubleshooting and installation manuals provided for the PBX and carrier system contain a great deal of information written for the system user. The availability of on-site spares and the replacement of other commercially available parts in a matter of a few weeks or less contributed to the ease of maintenance. The equipment is provided with quick-connect terminals and terminal blocks and requires no special tools for installation. Special wiring links are not needed at a single location. These factors and proper training have provided in a type of communications system which can be maintained by mining technicians with little assistance from outside sources.

5.2 Recommendations

The installation phase review revealed certain improvements should be incorporated into future systems. The capability to design and install a 17-station intercom system had been successfully demonstrated at Sunshine Mine. However, because of audio level problems, the complexities involved in building these units instead of an 8-station system, and the doubt as to the real need for 17 stations, it is recommended that all future systems use only 8 stations. This standard 8-station intercom system could be packaged in a smaller enclosure and would be easier to handle. The advantages of an additional 9 stations are far outweighed by the complexities involved in producing the 17-station system.

The dial tone and ringback tones on the intercom should also be changed in future versions. The present tone generators use standard modules to generate tone frequencies between 1250 and 1700 Hz. This frequency band can interfere with the high-frequency tones produced by the DTMF dial pads. Because of this interference problem and the piercing sound of high-frequency dial tones, it is recommended that the intercom dial and ringback tones use a single frequency in the band from 400 to 500 Hz.

The environmental packaging of the intercoms at the No. 10 shaft stations has provided adequate protection against the moist and corrosive environment in those areas. It is recommended that an ac lamp socket be provided for an additional heater on future designs. The present units have a 5 °F (approximate) internal temperature rise. This is adequate to keep the electronics dry but does not prevent corrosive moisture from eating away at the places where the epoxy paint has been chipped on the outside of the box. An additional 5 °F of internal heat is recommended to keep the outside of the unit dry.

The telephones are not normally powered in the on-hook state. After 1 year of operation, the units on the lower levels of the No. 10 shaft are just beginning to experience moisture-related problems on the dial pad switch contacts. The Klaxon now dissipates 1-1/2 watts of 24-volt power from the telephone battery. It is recommended that 5 to 10 watts of additional power should be dissipated in the telephones to keep them dry. The telephone hook switch has also been shown to require periodic cleaning on both the Jewell and No. 10 station telephones. To environmentally package future telephones for long-term protection in the environment of the Sunshine Mine or similar metal/nonmetal mines would require the following recommended modifications: rubberized or sealed dial pad, seals on the hook-switch assembly, the addition of a 1/2-watt Klaxon heater and a 5-watt telephone heater. Periodic performance tests are recommended to maintain a high level of system performance. These procedures detect marginal performance and may prevent costly repairs in the future.

In summary, the overall reliability of both hoist communication systems and carrier communication systems at Sunshine Mine have been good. Modifications to both systems have resulted in many improvements. The systems at the Sunshine Mine continues to expand and improve.

6.0 EQUIPMENT SPECIFICATIONS

6.1 Hoist Communication System

The electrical and mechanical specifications of the hoist communication system are listed below:

Electrical:

Frequency:	52 kHz
Modulation:	Narrow-band FM (12 F3) ± 3 kHz deviation
Supply voltage:	12 v dc, battery operated. 5-amp-hr sealed lead-acid battery or 12-v motorcycle battery, Yuasa Type 12 N 12 3B, or equivalent.
Current drain:	35 ma standby; 35 ma receive (handset); and 210 ma transmit
Operating time:	180 hours (10% RX, 10% TX, 80% standby with 12-amp-hr battery)
Transmit power output:	0.5 watt into 4.7-ohm resistive load
Frequency stability:	± 0.25 percent
Coupler output:	1.0 v ac induced voltage into 1 turn link secondary
Sensitivity:	10 microvolts for 20 db quieting
Squelch:	Operates at less than 10 microvolts
Selectivity:	-60 db at ± 20 kHz
Audio output:	0 dbm into handset, 2 watts into 8-ohm speaker

Mechanical:

	<u>Size (in)</u>	<u>Weight (lb)</u>
Transceiver	12.6 x 9.4 x 5.8	13.2
Battery charger:	6.0 x 6.0 x 2.4	3.6
Headframe coupler:	11.1 x 11.9 x 1.5	16.4
Cage coupler:	3.4 x 6.0 diameter	12.5

6.2 Carrier Communication System

a. Wescom 503 PBX

Electrical:

Line Capacity:	50 maximum
Intraoffice trunk capacity:	6 maximum
Central office trunk capacity:	12 maximum
Station loop resistance:	1500 ohms (including telephone)
Minimum leak resistance:	15,000 ohms
Ringing frequency:	20 Hz
Dial pulsing speed:	8 to 12 p/s
DTMF frequencies:	Conforms to Bell System Touch-Tone frequencies
Audible tone signals:	Conforms to Bell System precise tone plan
System impedance:	600 ohms
Bandwidth:	4 kHz nominal
Frequency response:	±1 db from 300 to 3400 Hz
Insertion loss:	Line-to-line, 2.0 dbm; line to trunk, 1.0 dbm
Harmonic distortion:	Less than 2%
Crosstalk coupling:	70 to 80 db from 200 Hz to 4 kHz
Idle channel noise:	0 count above 42 db
Longitudinal balance (line & trunk):	55 db from 300 to 2400 Hz
Primary power requirements:	117 v nominal, 60 Hz, single-phase, 20-ampere fusing

Mechanical:

<u>Size</u>	<u>Weight</u>
63 inches high, 22 inches wide, 28 inches deep nominal	300 pounds (fully equipped)

Environmental:

Temperature:	0 to 55 °C
Humidity	10 to 90%
Atmosphere	Nonexplosive and noncorrosive

b. Anaconda S6A

The electrical and mechanical specifications of the hoist Anaconda S6A are listed below:

Electrical:

Number of channels:	Up to seven on one wire pair
Channel net loss:	4 db \pm 2 db at 1 kHz
Channel bandpass:	300 to 3000 Hz with no more than 4 db deviation
μ f impedance:	900 ohms in series with 2.16 μ f
Echo return loss:	18 db or greater
Singing point:	15 db or greater
Commanders:	60 db dynamic range
Modulation type:	Amplitude (AM)
Frequency allocation:	Subscriber to central office: 8 to 56 kHz; central office to subscriber: 76 to 124 kHz
Facilities:	Exchange grade 19, 22, 24, or 26 ga, air or filled core, 0.083 mf/mile any combination
Repeater spacing:	35 db at 116 kHz \pm 3 db maximum
Number of repeaters:	9
Protection:	Gas tube/Zener - all wire interfaces
Dialing:	Rotary dial 10 p/s \pm 2 tone pad
μ f drop resistance:	400 ohms, including telephone set for 23 ma talk current
Power:	Central Office: -48 v, 1 amp nominal -44 to -56 v. Central Office to repeater line: \pm 96, \pm 135, \pm 150, \pm 165, or external \pm 135
Subscriber power:	\pm 96, \pm 135, \pm 150, or \pm 165 volts

Environmental:

Relative humidity: 0 to 99% continuous operation

Temperature: -20 to 50 °C operating

c. Telephones

Electrical:

Dial type: Push button metropolitan, DTMF tones conforming with Bell System specification.

Network: Standard telephone hybrid network and handset.

Ringer: Weatherized 24-volt Klaxon, single or twin horn

Ringer output: 1.5 watts (nominal) 97 db at 10 feet

Ringer signaling: Switched ground on intercom telephones

Local signaling: Press-to-test button for sounding Klaxon

Intercom phone connections: Tip, ring, -24 volt, switched ground, and ground

PBX phone connections: Tip, ring, -24 volt, ground

Power requirements: 63 ma at 24 volts to sound the Klaxon, minimum of 23 ma talk battery current, 1.5 watts for Klaxon heater

Mechanical:

Housing material: Cast aluminum, with door

Finish: Red baked enamel on telephone housing, baked silver hammertone on Klaxon

Environmental:

Temperature: -30 to 55 °C

Humidity: 0 to 99%, no condensation

d. Pulsecom Datalok 10

The electrical and mechanical specifications of the Pulsecom Datalok 10 monitor and control system are listed below.

1. Micro-Master Unit

Electrical:

System type:	Polled system: master station polls remote station in sequence
Data rate:	110 baud
Frequency:	Audio channels between 2500 and 3100 Hz
Modulation:	Frequency shift keying (FSK)
System connections:	Wired to data bus of master station
Power:	117 v ac nominal

Mechanical:

Size:	Display 19 x 12 x 6 inches, microprocessor 19 x 15 x 9 inches
Mounting:	Telemetry panel and microprocessor unit are 19-inch rack mounted

Environmental:

Temperature:	0 to 50 °C operating, -20 to 55 °C nonoperating
Relative humidity:	20 to 90%, no condensation

2. Master Station

Electrical:

Polling capability:	3 remote stations
Control capability:	Up to 99 relays per remote
Alarm display:	24 alarm points per remote station. LED, flashing COS light, and audible buzzer signal on alarm.
Telemetry display:	2 analog values per remote station, 3-1/2-digit readout
System connections:	2 wires to FSK transmitters and receiver shelf
Power:	-24 v dc at 500 ma, or 48 v dc at 230 ma.

Mechanical:

Size: 19 x 14 x 12 inches
Mounting: 19-inch rack mounted, Rock Burst monitor room master is packaged in a wall mounted enclosure

Environmental:

Temperature: 0 to 50 °C operating
Relative humidity: 20 to 90%, no condensation

3. Remote Stations

Electrical:

Alarm capability: 24 relay contacts (normally open or normally closed)
Alarm display: 24 LED's, one for each relay contact, audible alarm
Control capability: Two analog inputs. Input ranges: 0 to 2, and 0 to 20 volts; and 0 to 2, and 0 to 20 ma
Backup power: 24-volt batteries provide over 24 hours of operation without input power
Maintenance line: Panel telephone mounted with remote station
System connections: 2 wires to FSK transmitter and receiver shelf, 4 wires to panel telephone
Power requirements: 117 v ac, 1 ampere

Mechanical:

Mounting: Wall mounted drip-proof enclosure
Size: 25 x 24 x 12 inches
Finish: Epoxy paint

Environmental:

Temperature: 0 to 45 °C operating, -20 to 55 °C nonoperating
Humidity: 20 to 99%

7.0 PERFORMANCE TESTS

7.1 Hoist Communication System Performance Tests

Performance tests were made at Sunshine on both hoist communication systems prior to installation. The tests included individual component as well as integrated system tests. After installation, tests were again performed to verify proper system operation. Both systems were placed in service and not retested until 1 month before system demonstration and acceptance in January 1978. Tests performed before installation were extensive and included the following:

- a. Receiver sensitivity
- b. Transmit frequency
- c. Transmit power
- d. Dc current drain
- e. System talkout

7.1.1 Data from the tests is as follows:

a. Receiver Sensitivity (20 db quieting)

Jewell cage transceiver - 41 μv
Jewell hoist transceiver - 31 μv
No. 10 cage transceiver - 50 μv
No. 10 hoist transceiver - 58 μv

b. Transmit Frequency (52 kHz \pm 50 Hz)

Jewell cage transceiver - 51.971 kHz
Jewell hoist transceiver - 51.974 kHz
No. 10 cage transceiver - 51.995 kHz
No. 10 hoist transceiver - 52.009 kHz

c. Transmit Power (1.5 v ac \pm 0.1 v across 4.7-ohm resistor)

Jewell cage transceiver - 1.41 v ac
Jewell hoist transceiver - 1.5 v ac
No. 10 cage transceiver - 1.46 v ac
No. 10 hoist transceiver - 1.46 v ac

d. Dc Current Drain (ma dc)

	<u>Squelched</u>	<u>Receiver</u>	<u>Transmit</u>
Jewell cage transceiver	39	275	195
Jewell hoist transceiver	40	250	205
No. 10 cage transceiver	37	470	190
No. 10 hoist transceiver	37	180	200

e. System Talkout

Check okay, excellent audio quality for entire travel of cage for both systems.

7.1.2 System signal strength tests at discrete cage depths were taken 1 month after installation and then again 18 months later, shortly before system acceptance and demonstration in January 1978. All measurements were taken at the coupler input to each hoist room transceiver with the cage transceivers on transmit.

a. Jewell Shaft System

<u>Level</u>	<u>Signal Strength (mv)</u>	
	<u>1 month after installation</u>	<u>18 months after installation</u>
Collar	2.0	2.5
800	1.7	3.5
1700	1.7	1.5
2200	3.5	3.0
2700	4.5	2.8
3500	3.2	-
3700	2.6	2.2

b. No. 10 Shaft System

<u>Level</u>	<u>Signal Strength (mv)</u>	
	<u>1 month after installation</u>	<u>18 months after installation</u>
3700	1.4	0.3
4000	1.3	0.5
4200	1.7	0.6
4400	-	1.0
4600	7.0	0.7
4800	7.0	0.8
5200	-	1.2
5600	-	0.6
5800	-	1.5

c. 8-Station and 17-Station Intercom

The electrical and mechanical specifications of the hoist 8-Station and 17-Station Intercom Units systems are listed below:

Electrical:

Line capacity:	8 or 17 stations
Input signal level:	-20 dbm to +3 dbm
Signaling:	DTMF, conforms to Bell System Touch-Tone frequencies
Minimum interdigital interval:	40 msec
Minimum digit recognition time:	40 msec
Input impedance (from station telephone):	3000 ohms
Input impedance (from PBX input):	Greater than 10 kilohms on hook, 1000 ohms off hook
Telephone talk battery:	-24 volts
Telephone ringing:	Switched ground
Input power:	117 v ac nominal 8 Station: 2 amp ac 17 Station: 4 amp ac
Backup power:	24 hr on internal batteries, fuse protected.
Station telephone connections:	Tip, ring, ground, -24 volts, and switched ground to each station.

Mechanical:

	<u>Size (in)</u>	<u>Weight (lb)</u>	<u>Finish</u>
	24 x 24 x 12	160 lb for 8-station, 200 lb for 17-station	Epoxy paint on exterior
Construction:	Drip-proof enclosure with access door		

<u>Equipment</u>	<u>Size (in)</u>	<u>Weight (lb)</u>
Central office assembly:	33.2 x 33.2 x 15.4	55.3
Single subscriber terminal:	14.8 x 4.8 x 5.5	3.6
Dual subscriber terminal:	17.8 x 7.4 x 6.4	10
Remote power supply:	19.10 x 33.19 x 16.44	73
Carrier line termination:	1.5 diameter x 0.7	28 grams
Signal splitter:	1.5 diameter x 0.7	28 grams
Environmental:		
Relative humidity:	0 to 95%	
Temperature:	-1 to 60 °C for central office equipment; -40 to 60 °C for subscriber terminal equipment	

7.2 Carrier Communications System Performance Tests

Tests were performed on the equipment at Rockwell-Collins prior to system installation. The tests included individual component and system evaluation to verify proper operation. All equipment was tested again after installation. Equipment which failed to meet minimum performance standards was returned to the manufacturer for repair. Logbooks were maintained of all repairs and tests that were used for reliability and performance tracking. Frequent common failures were identified and corrective action taken.

During the course of system installation, several checks were made to ensure continued system operation. These checks included the following:

- a. Periodic random calling to ensure clear connections with no misplaced or dropped calls.
- b. Operation of telephone features to verify proper operation, for example, PBX access, intercom all call, and busy override on attendant's console.
- c. Removed underground power to check operation of equipment on battery power (at least 8 hours).
- d. Removed power to check operation of uninterruptible power supply system (at least 24 hours).

These checks afforded a means of verifying overall system operation and locating and identifying problems. Records were kept of all checks and compared with previous data to determine trends in operation.

After installation and testing, a formal demonstration was performed and system accepted by Sunshine. The USBM, Sunshine Mine, and Rockwell-Collins were represented.

A summary of these tests and the results are outlined below.

7.2.1 Tests Performed

a. Carrier Signal Strength

Using the Anaconda 306A test set, the signal strength of the carrier frequencies at the central office and all intercom locations were measured and recorded. All levels should be greater than -35 dbm.

1. Jewell System

Channel	Frequency kHz	Carrier Signal Strength (dbm)				
		RBM Room	Jewell 3700	Jewell 3100	No. 10 3100	Surface
1	76	-4.7	-10.6	-11.7	-22.3	-23.8
2	84	-3.1	-9.5	-10.5	-21.5	-22.8
3	92	-2.3	-9.5	-10.4	-21.7	-23.1
4	100	0.0	-7.5	-8.3	-20.0	-21.7
5	108	-0.5	-8.3	-9.0	-21.0	-22.8
6	116	+1.5	-6.2	-6.9	-19.0	-21.2
7	124	+0.6	-	-	-	-

2. No. 10 System

Channel	Frequency kHz	Carrier Signal Strength (dbm)				
		RBM Room	4200 Level	4800 Level	5200 Level	5600 Level
1	76	-	-	-	-	-
2	84	-4.1	-10.0	-13.5	-24.5	-23.8
3	92	-2.2	-11.7	-10.6	-21.4	-20.7
4	100	-1.7	-9.0	-10.2	-19.2	-19.5
5	108	-2.5	-9.8	-10.7	-19.6	-20.0
6	116	+0.9	-7.2	-6.7	-16.2	-16.1
7	124	-	-	-	-	-

b. Audio Signal Attenuation

Audio signal losses from one PBX line circuit to each intercom's audio bus were measured using a 1-kHz tone generator and the Anaconda 306A tester. These measurements were recorded with all intercom telephones on hook and then with one telephone off hook. The signal loading caused by this additional party-line phone is evident. Attenuation should be less than 10 db with no telephones off hook, and less than 15 db with a single telephone off hook.

<u>Location</u>	<u>Audio Tone Attenuation (db)</u>	
	<u>All phones on hook</u>	<u>One phone off hook</u>
Jewell surface intercom No. 26	8.7	14.3
Jewell surface intercom No. 27	10.3	15.8
3100 Jewell intercom No. 31	6.0	11.8
3700 Jewell intercom No. 37	7.1	13.8
3100 No. 10 intercom No. 39	8.9	14.0
4200 No. 10 intercom No. 42	6.7	14.0
4800 No. 10 intercom No. 48	6.9	13.5
5200 No. 10 intercom No. 52	4.8	10.2
5600 No. 10 intercom No. 56	4.8	11.2

c. System Operation Verification

The following system operating features were checked and verified:

1. Telephone operation - Calls were made from a station telephone on each intercom to all other telephones in the system. All system tones were functional and audio levels were good.
2. Functional tests - The intercom units all call capability, attendant's console, PBX diagnostic panel, and loud Klaxons were each checked for proper operation. All equipment and associated features tested correctly.

d. System Battery Operation

117 v ac was removed from each intercom unit. Calls were then placed throughout the system to verify proper intercom operation while on battery power. The ac power was also removed from the uninterruptible power supply system for 24 hours. No degradation in system operation was experienced during emergency battery-power operation.

8.0 SYSTEM COSTS

8.1 Carrier Communication System

The approximate costs for subsystem and components of the Sunshine system purchased in 1976 are listed below. An estimate of packaging cost which is required to make these items suitable for mine installation is also included. The packaging costs do not include the engineering design involved in the packaging, only labor and component costs required to build the assemblies as described in the hardware section.

a. PBX Costs	<u>Subtotals</u>	<u>Totals</u>
Basic Wescom 503 PBX with 30 line circuits	8,000	
503 spare parts (minimum)	1,000	
Trunking addition (2 trunks)	700	
Attendant's console	1,300	
Packaging - not applicable	-	
Total	\$11,000	<u>\$11,000</u>
b. Anaconda S6A Carrier System		
One 7-channel system including central office shelf, subscriber drops, and line treatment equipment	6,000	
Packing of central office for mine use	<u>1,000</u>	
	\$7,000	
Total Sunshine Cost: 2 systems	14,000	
spares	2,250	
Total		<u>\$16,050</u>
c. UPS system 2184-ampere-hour batteries	15,100	15,100
d. Wescom 8-station intercom	1,840	
Packaging for mine use	<u>1,500</u>	
	\$3,340	
Total of eight 8-station intercoms for Sunshine		<u>\$26,720</u>

	<u>Subtotals</u>	<u>Total</u>
e. Wescom 17-station intercom	2,640	
Packaging for mine use	<u>1,700</u>	
	\$4,340	
Total of two 17-station intercoms for Sunshine		<u>\$ 8,680</u>
f. Allen-Tel weatherized telephone	130	
Packaging for system use	<u>75</u>	
	205	
Total of 40 on Sunshine System		<u>\$ 8,200</u>
g. Intercom Spares		\$ 1,200
h. Test equipment, 2 test telephones, and Anaconda 306A tester		<u>\$ 1,180</u>
Total hardware costs (estimated)		<u>\$88,330</u>

NOTE

Wiring costs are not included in these estimates. Six-pair, No. 22 AWG are recommended for installation of telephones to the intercoms. A twisted pair of No. 22 AWG or larger should be used for the carrier system in mine applications.

These costs do not include the system engineering and other design costs associated with installing a custom system. The costs reflect only what one may expect to pay for this type of system if all equipments are commercially available. Prices may have changed considerably since 1976 when the equipment was purchased.

8.2 Monitor and Control System

The approximate costs for equipment assemblies and components of the Sunshine mine monitor and control system procured in 1977 are listed below. An estimate of packaging costs which is required to make these items suitable for mine installation is also included. The packaging costs do not include the engineering design that was involved in the packaging; only the labor and material costs required to build the assemblies as described in the hardware description section are listed.

a. Surface Master and Micro-Master Rack Assembly

	<u>Subtotal</u>	<u>Total</u>
Pulsecom Datalok 10 master shelf assembly	3,900	
Micro-Master, with telemetry display panel	6,650	

	<u>Subtotal</u>	<u>Total</u>
Teleprinter	750	
Rack, backup battery capability, and packaging	<u>800</u>	
Total Cost		\$12,100
b. RBM Room Backup Master		
Pulsecom Datalok 10 master shelf assembly	3,900	
Teleprinter	750	
Packaging	<u>200</u>	
Total Cost	\$4,850	\$4,850
c. Remote Stations		
Pulsecom Datalok 10 remote station shelf assembly	2,300	
Packaging, environment enclosure, battery backup, etc	<u>700</u>	
	\$3,000	
Total Remotes		\$9,000
d. Datalok 10 Spares		\$2,900
Total system costs, hardware and packaging labor		\$28,850

Sensor costs are not included in the above estimates. Various interface devices are required to translate the analog parameter such as voltage, current, temperature or percent CO into 0 to 20 volts or 0 to 20 ma inputs for the a/d cards.

REFERENCES

1. Chufo, R. L. and Vancura, P. L., "The Installation, Operation, and Maintenance of an Underground Mine Wide Radio System," IEEE - Industry Applications Society Conf. Proc., 1976, pp 1196-1202.
2. Sack, K. H. and Chufo, R. L., "Hoist Radio Communications," Underground Mine Communications (in four parts) Part 3, Haulage Systems/compiled by staff, Mining Research, PMSRC, US Department of the Interior, USBM, 1977, pp 28-41.
3. Chufo, R. L., "Leaky-Feeder Ultrahigh-Frequency Radio," Underground Mine Communications (in four parts) Part 3, Haulage Systems/compiled by staff, Mining Research, PMSRC, US Department of the Interior, USBM, 1977, pp 12-23.
4. Parkinson, H. E., "Mine Communications," Proc Second WVU Conference on Coal Mine Electrotechnology, June 12-14, 1974, (NTIS PB 244/253/AS) pp 5-1/5-5.
5. Anderson, D. T. and Vanous J. A., "A Frequency Diversity Communications System for Mines," in Proc. Second WVU Conference on Coal Mine Electrotechnology, June 12-14, 1974, (NTIS PB 244/253/AS) pp 11-1/11-13.
6. Long, R. G.; Ginty, J. J.; and Lagace, R. L; "Development of Guidelines for Underground Mine Communications," in Proc. Second WVU Conference on Coal Mine Electrotechnology, June 12-14, 1974, (NTIS PB 244/253/AS) pp 9-1/9-8.
7. Collins Commercial Telecommunications Division, Rockwell International, "Technical Report," Communication and Monitoring Systems, prepared for the US Bureau of Mines under provisions of Contract SO133035, June 28, 1974.
8. Collins Commercial Telecommunications Division, Rockwell International, "Hoist Radio System for Deep Shafts," Final Report, Bureau of Mines Contract HO230034, June 30, 1976.
9. Bethlehem Mines Corporation, "Grace Mine" brochure.
10. Collins Commercial Telecommunications Division, Rockwell International, Engineering and Administrative Services Contract Monthly Reports, Bureau of Mines Contract SO133035, June, 1973 - April, 1978.
11. Dobroski, H., W. C. Laubengayer, and R. R. Godard. "Experience with an Integrated Computer - Controlled Communications and Monitoring System at the Robena Mine." In Proc Third WVU Conference on Coal Mine Electrotechnology, August 4-6, 1976, pp 15-1/15-13.
12. Dobroski, H. "Whole Mine Communications and Monitoring System". Proc Internat Conf on Coal Mine Safety Res, Washington, D.C., 1975, pp 3-4.1/3-4.7.
13. Dobroski, H., "A Coaxial - Cable Telephone System." Underground Mine Communications (in four parts). #1 Mine Telephone Systems, compiled by staff - Mining Research, PMSRC, US Department of the Interior, USBM, 1977, pp 42-57.

14. Chironis, H. P., "Super Communications System Designed to Enhance Control of Operations at Robena Mine". Coal Age Volume 81, No 6, 1976, pp 86-92.
15. Combellick, J. D., "A New Whole Mine Communication System". In Proc Second WVU Conference on Coal Mine Electrotechnology, June 12-41, 1974, pp 7-1/76.
16. Aldridge, M. D., R. E. Swartwont, N. S. Smith Jr., R. S. Nutter, J. L. Boyles, West Virginia University. Electronic Monitoring and Control of Mine Ventilation, in Proc Third WVU Conference on Coal Mine Electrotechnology, August 4-6, 1976, pp 23-1/23-10.
17. Collins Commercial Telecommunications Division, Rockwell International. System Study of Coal Mine Communications, Final Rep Vol 1-4, Bureau of Mines Contracts SO122076 and HO232056, 1972; 1973.
18. Collins Commercial Telecommunications Division, Rockwell International. "Mine Communications and Monitoring System Operation and Maintenance Manual," Bureau of Mines Contract HO346089, 1974.
19. Collins Commercial Telecommunications Division, Rockwell International. "Collins ARX-101 System Functional Description," November 15, 1976.
20. Collins Commercial Telecommunications Division, Rockwell International. "Mine Communications and Monitoring System Preliminary Design for US Steel Robena No. 4," Bureau of Mines Contract SO133035, September 19, 1973.